

International specialized medium for agricultural mechanization in developing countries

ISSN 0084-5841

AMA

AGRICULTURAL MECHANIZATION IN ASIA, AFRICA AND LATIN AMERICA

VOL.38, No.1, WINTER 2007

FARM MACHINERY INDUSTRIAL RESEARCH CORP.

International specialized medium for agricultural mechanization in developing countries

ISSN 0084-5841

AMA

AGRICULTURAL MECHANIZATION IN ASIA, AFRICA AND LATIN AMERICA

Vol.38, No.1, WINTER 2007

Edited by

YOSHISUKE KISHIDA

Published quarterly by

Farm Machinery Industrial Research Corp.

in cooperation with

The Shin-Norinsha Co., Ltd.

and

The International Farm Mechanization Research Service

TOKYO

Yoshisuke Kishida, Publisher & Chief Editor

Contributing Editors and Cooperators

- AFRICA -

Kayombo, Benedict (Botswana)
Fonteh, Fru Mathias (Cameroon)
El Behery, A.A.K. (Egypt)
El Hossary, A.M. (Egypt)
Pathak, B.S. (Ethiopia)
Bani, Richard Jinks (Ghana)
Djokoto, Israel Kofi (Ghana)
Some, D. Kimutaiarap (Kenya)
Houmy, Karim (Morocco)
Igbeka, Joseph C. (Nigeria)
Odigboh, E.U. (Nigeria)
Oni, Kayode C. (Nigeria)
Kuyembah, N.G. (Sierra Leone)
Abdoun, Abdien Hassan (Sudan)
Saeed, Amir Bakheit (Sudan)
Khatibu, Abdissalam I. (Tanzania)
Baryeh, Edward A. (Zimbabwe)
Tembo, Solomon (Zimbabwe)

- AMERICAS -

Cetrangolo, Hugo Alfredo (Argentina)
Naas, Irenilza de Alencar (Brazil)
Ghaly, Abdelkader E. (Canada)
Hetz, Edmundo J. (Chile)
Valenzuela, A.A. (Chile)
Aguirre, Robert (Colombia)
Ulloa-Torres, Omar (Costa Rica)
Magana, S.G. Campos (Mexico)
Ortiz-Laurel, H. (Mexico)
Chancellor, William J. (U.S.A.)
Goyal, Megh Raj (U.S.A.)
Mahapatra, Ajit K. (U.S.A.)
Philips, Allan L. (U.S.A.)

- ASIA and OCEANIA -

Quick, G.R. (Australia)
Farouk, Shah M. (Bangladesh)
Hussain, Daulat (Bangladesh)
Mazed, M.A. (Bangladesh)
Wangchen, Chetem (Bhutan)
Wang, Wanjun (China)
Illangantileke, S. (India)
Ilyas, S. M. (India)
Michael, A.M. (India)
Ojha, T.P. (India)

Verma, S.R. (India)

Soedjatmiko (Indonesia)
Behrooz-Lar, Mansoor (Iran)
Minaei, Saeid (Iran)
Sakai, Jun (Japan)
Snobar, Bassam A. (Jordan)
Chung, Chang Joo (Korea)
Lee, Chul Choo (Korea)
Bardaie, Muhamad Zohadie (Malaysia)
Pariyar, Madan (Nepal)
Ampratwum, David Boakye (Oman)
Eldin, Eltag Seif (Oman)
Chaudhry, Allah Ditta (Pakistan)
Mughal, A.Q. (Pakistan)
Rehman, Rafiq ur (Pakistan)
Devrajani, Bherular T. (Pakistan)
Abu-Khalaf, Nawaf A. (Palestine)
Nath, Surya (Papua New Guinea)
Lantin, Reynaldo M. (Philippines)
Venturina, Ricardo P. (Philippines)
Al-suhaibani, Saleh Abdulrahman (Saudi Arabia)
Al-Amri, Ali Mufarreh Saleh (Saudi Arabia)
Chang, Sen-Fuh (Taiwan)
Peng, Tieng-song (Taiwan)
Krishnasreni, Suraweth (Thailand)
Phongsupasamit, Surin (Thailand)
Rojanasaroj. C. (Thailand)
Salokhe, Vilas M. (Thailand)
Singh, Gajendra (Thailand)
Pinar, Yunus (Turkey)
Haffar, Imad (United Arab Emirates)
Lang, Pham Van (Viet Nam)
Nguyen Hay (Viet Nam)
Hazza'a, Abdulsamad Abdulmalik (Yemen)

- EUROPE -

Kaloyanov, Anastas P. (Bulgaria)
Kic, Pavel (Czech)
Have, Henrik (Denmark)
Pellizzi, Giuseppe (Italy)
Wanders, A. Anne (Netherlands)
Pawlak, Jan (Poland)
Marchenko, Oleg S. (Russia)
Kilgour, John (U.K.)
Martinov, Milan (Yugoslavia)

EDITORIAL STAFF

(Tel.+81-(0)3-3291-5718)

Yoshisuke Kishida, Chief Editor
Shinjiro Tetsuka, Managing Editor
Noriyuki Muramatsu, Assistant Editor
Zachary A. Henry, Editorial Consultant

ADVERTISING

(Tel.+81-(0)3-3291-3672)

Yoshito Nakajima, Manager (Head Office)
Hiroshi Yamamoto, Manager (Branch Office)
Advertising Rate: 300 thousand yen per page

CIRCULATION

(Tel.+81-(0)3-3291-5718)

(Fax +81-(0)3-3291-5717)

Editorial, Advertising and Circulation Headquarters
7, 2-chome, Kanda Nishikicho, Chiyoda-ku, Tokyo 101-0054, Japan
URL: <http://www.shin-norin.co.jp>
E-Mail: sinnorin@blue.ocn.ne.jp

Copyright © 2007 by

FARM MACHINERY INDUSTRIAL RESEARCH CORP.

SHIN-NORIN Building

7, 2-chome, Kanda Nishikicho, Chiyoda-ku, Tokyo 101-0054, Japan

Printed in Japan

EDITORIAL

It is a record-making warm winter season all over the world this year. They had rainfall instead of snowfall in Oslo, Norway; the temperature went up to over 20 degrees in New York. Snow has never lain this year, even in the areas of high snowfall in Japan. Some scientists say that global warming has been accelerated recently. Greenhouse effect gas emissions are continually increasing, forests are diminishing, and the eco-system is losing its balance. This is caused by growing population and economic activities that might have led to global warming.

Most national governments signed and ratified the Kyoto Protocol aimed at combating global warming. However, the reduction target of greenhouse gases emissions proved to be hardly achieved in Japan. As greenhouse gases are released largely by the burning of fossil fuels, many countries and organizations promote renewable energies. While solar energy and wind power are used as common renewable energy sources, more recently, the use of biomass energy especially attracts attention. With the background of the September 11 attack, the United States has adopted a new energy plan aimed at 75 percent reduction of oil dependency on Middle East Asia by 2025. Also in the National Renewable Energy Standard issued in 2005, it is required that the production of ethanol be increased to 7.5 billion gallons per year by 2012. In the 2007 State of the Union Address, U.S. President G.W. Bush asked Congress to work to reduce gasoline usage in the U.S. by 20 percent over the next ten years and to increase ethanol production capacity up to 35 billion gallons.

Ethanol manufacturing consumes so much corn that the demand for corn used for ethanol production is rapidly growing, not only in U.S. but also in China. This leads to long term rise in corn price. Corn and sugar cane are the best agricultural products for energy production. The present concern is whether increasing corn demand can be supplied by increasing corn yield. On the other hand, a large number of people are still starving and enough food supply for the increasing population remains our critical concern, while a part of farm production is used for energy and not for food.

In this event, the most effective solution to what is going on earth is raising productivity on the limited farmland; in other words, increasing land productivity through timely farm work by intensified mechanization. The role of farm mechanization has proven to be the most important in this century. With this in mind, AMA readers and contributors are expected to join the efforts for further development of agricultural mechanization.

Yoshisuke Kishida
Chief Editor

Tokyo, Japan
February 2007

CONTENTS

AGRICULTURAL MECHANIZATION IN ASIA, AFRICA AND LATIN AMERICA

Vol.38, No.1, February 2007

Yoshisuke Kishida	7	Editorial
Sedat Çalisir	9	The Evaluation of Performance and Energy Usage in Submersible Deep Well Irrigation Pumping Plants
V. B. Shambhu, R. B. Ram	18	Status of Farm Mechanization in Nalanda District of Bihar
B. K. Behera, B. P. Varshney S. Swain	23	Effect of Puddling on Physical Prosperities of Soil and Rice Yield
B. K. Behera, B. P. Varshney S. Swain	29	Ground Contact Pressure and Soil Sedimentation Period Affecting Transplanter Sinkage and its Performance
A. F. Alonge, A. A. Opeloyeru	33	Development of a Reinforced Mud Silo
M. W. Ullah, S. Anad	39	Current Status, Constraints and Potentiality of Agricultural Mechanization in Fiji
Ghanshyam Tiwari Ajay Kumar Sharma, K. P. Pandey	46	Performance of some Pneumatic Tires Used in Camel Carts on Sandy Terrain
Hamid Al-Jalil, Jumah Amayreh Mohamad Al-Widyan	51	Feasibility of Collecting Ambient Air Moisture by Forced Condensation
Binisam, K. Kathirvel, R. Manian T. Senthikumar	55	Energy Cost of Riding and Walking Type Power Tillers
K. Kathirvel, Binisam, R. Manian T. Senthikumar	61	Vibration Mapping of Walking and Riding Type Power Tillers
Ahmed Al-Marshudi	68	Oman Traditional Farms: Changes and Improvement of Farms in Oman
Sukhbir Singh Dinesh Kumar Vatsa	74	Prospects of Maize Cultivation Mechanization in Hills of Himachal Pradesh
M. Din, P. S. Deshmukh N. Ravisankar, S. G. Choudhuri	78	Farm Mechanization in Andaman and Nicobar Island
H. Ortiz-Laurel, D. Rössel	83	Current Status of Animal Traction in Mexico
Abstracts	89	
News	91	
New Publications from ASABE	92	

	★		★		★
Co-operating Editor					93
Back Issues					96

Instructions to AMA Contributors	98
--	----

The Evaluation of Performance and Energy Usage in Submersible Deep Well Irrigation Pumping Plants

by

Sedat Çalisir

Professor
Department of Agricultural Machinery,
Faculty of Agriculture,
University of Selçuk, 42031 Konya
TURKEY
scalisir@selcuk.edu.tr



Abstract

Material performance and energy usage of submersible irrigation pumping plants were evaluated in this study. This research was carried out in Konya vicinity of Turkey. In general submersible irrigation pumping plants were tested. Total mass per pumping plant, flow rate, total dynamic head, specific draw-down of well, diving depth, actual performance (system efficiency), performance rating and specific total energy consumption were found to be $1,283.8 \pm 27.6$ kg/unit, 41.1 ± 1.0 L/s, 56.1 ± 2.1 m, 0.25 ± 0.02 m per L/s, 12.1 ± 0.6 m, 52 ± 1 %, 78 ± 1 % and 2.93 ± 0.10 MJ m⁻³, respectively. According to Nebraska Performance Criteria (NPC), potential of energy saving rating was determined as 22 % in all of the plants. In addition, the simple and useful regression equations for specific total energy consumption depending on motor power, flow rate and total dynamic head were obtained.

Introduction

In arid and semiarid climate re-

gions, irrigation is one of the techniques used for increasing agricultural production. Subterranean water sources are used in agricultural irrigation either due to insufficiency of surface water sources or due to its uneconomical transportation. To benefit from subterranean water, opening and installation of drilling well and buying of deep well pumps are expensive investment.

There are approximately 80,000 deep well pumps in Turkey (SIS, 2001). The submersible deep well irrigation pumps were at the 90 % level for agricultural irrigation in the past decade because of increasing dynamic water level, wide spread electrical energy and the technological developments of drilling machines, pumps and submersible motors. However, vertical line shaft deep well pumps lubricated with oil were preferred in conditions which included silt-sand (>50 kgm⁻³) of well water and in regions without electrical energy (Schulz, 1977 and Kosyna, 1984).

Turkey has useable subterranean water source of 12 billion m³/year. According to 1997 data, consumption rate was 50 %. Approximately 504,965 ha were irrigated with 75 %

of this consumption (SHW, 1997).

Energy efficiency determined by the energy balance of the plant is an important indicator in agricultural production (Heyland & Solonsky, 1979; Smil, 1983; Dipenbrock et al., 1995; Moerschner et al., 1997; Hülshberger et al., 2001). The supply energy of irrigation water is an important input of plant energy balance in arid and semiarid regions (Sloggett, 1992; Mrini et al., 2001). Instead of calculating equivalent irrigation water assurance energy, water source, type of pump and driven source, the reference value of 0.63 MJ m⁻³ in Turkey was used (Yaldiz et al., 1993).

The aim of this study was to evaluate the used material, system efficiency and usage energy for the supply of unit irrigation water in submersible deep well irrigation pumping plants.

Acknowledgment: The author wishes to acknowledge the 4th Regional Directorate of State Hydraulic Works (SHW) and the subterranean water irrigation cooperative for helpful on this work.

Material and Methods

Working Region

The study was carried out in July and August of 2001-2002 in the Konya region. Konya is the largest agricultural region of Turkey with area of 41.94 km² at middle Anatolia. The annual average rainfall is 300 mm and the altitude is 1,016 m (Anonymous, 2002).

Material Selection

There are 23 subterranean water irrigation cooperatives in the study area (Anonymous, 2000). The selection of submersible deep well pumps in these cooperatives was based on motor power, numerical density, and suitability for measuring criteria. A sample volume was selected at 90 % confidence range and 5 % degree of importance with respect to the stage sampling method in order to represent the population (McClave and Benson, 1988). Motor power of pumping plants that depend on flow rate and total dynamic head, were 22, 30, 37, 45 and 55 kW, and the distribution according to motor power of 110 plants were 12, 31, 32, 26 and 9, respectively.

Generally Properties of Pumping Plants

Each pumping plant has an ammeter, a voltmeter and an electric counter. There is no control valve in the discharge pipe and the discharge pipe is commonly connected to a sprinkler irrigation line or it transmitted water directly to the field. In addition, there is a hole in the equip-

ping pipe to measure the dynamic water level of the well. Technical properties of the pumping plants such as well depth, pump diving depth, column pipe diameter, motor characteristics, stage number and pump set total mass were provided from records of 4th Regional Directorate of State Hydraulic Works and manufacturer catalogues (Anonymous, 2000). Instruments used in performance tests of pumping plants are shown in **Table 1**.

Audit of Testing

Power consumption from the network in present working conditions of tested plants were determined by measuring from discharge of the electrical dashboard. The system was then stopped. Measurement instruments, which were a pressure gauge, orifice meter and control valve, were connected to the system at a suitable discharge pipe diameter of the plants. About 15-20 minutes after system start, the discharge pressure, flow rate, power consumed and dynamic level were measured. Again, system was stopped and after 30 minutes and static level was measured (Hansen, 1974; Saqip & Khan, 1993). Static and dynamic levels were measured by putting an electrical well sounder between the pump column pipe and well equipping pipe. Calibrated orifice meters of about 3/4", 4/6", 5/6" and 6/8" with respect to discharge pipe diameter of plants, were used at 4-1/2", 5-1/2", 6-5/8" and 8-5/8" discharge pipe respectively (Karassik et al., 1986).

Evaluating of Performance Test Results

Actual performance of pumping irrigation plants was calculated by using the equations below (Hanson, 1994; Conlon et al., 1999; Hla & Scherer, 2001; Loftis & Miles, 2001).

$$AP = ((Q * TDH * \gamma) / (102 * NI)) * 100 \quad \dots\dots\dots(1)$$

$$TDH = PWL + 10.2 * P + VH + FL \quad \dots\dots\dots(2)$$

$$VH = v^2 / 2g \quad \dots\dots\dots(3)$$

$$FL = L * J \quad \dots\dots\dots(4)$$

Water velocity at the pump discharge pipe was calculated by using the measured flow rate and discharge pipe diameter from the continuity equation. Friction losses of the column pipe, were calculated from the hydraulic gradient (j) which was given by the manufacturer as a function of flow rate and pipe diameter. Specific mass of water was assumed as (γ) 1 kg L⁻¹ since the pumping water was clear and its temperature (t) varied between 0-30 °C (Karassik et al., 1986).

Specific drawdown of pumping wells were determined by the ratio of the difference between the dynamic level and the static level to the consumed flow rate (Eqn. 5) (Saqip and Khan, 1993). Diving depth was calculated from the difference between the column line length and the pumping water level (Eqn. 6) (Schulz, 1977).

$$\Delta = (PWL - SL) / Q \quad \dots\dots\dots(5)$$

$$DD = L - PWL \quad \dots\dots\dots(6)$$

A plant's performance rating (PR) was determined by the ratio of system efficiency to 0.66 value known as a Nebraska Performance Criteria (NPC) (Eqn. 9). NPC value is the optimum accessible system efficiency (pump efficiency 75 % and motor efficiency 88 %), (USDA1997, Conlon et al., 1999).

$$PR = [AP / NPC] * 100 \quad \dots\dots\dots(7)$$

Evaluating of Direct and Indirect Energy Usage

Pumping plants not only consumed system energy but also the most efficient system conversion

Table 1 Instruments used in tests

Parameter/date	Units	Instruments used
Flow rate (Q)	L/s	Calibrated orifice meters (3/4"), (4/6"), (5/6"), (6/8")
Power consumed (NI)	kW	Power master (Electric power analyser)
Static (SL) and pumping water levels (PWL)	m	Electric well sounder
Discharge pressure (P) before control valve	bar	Test grade dial pressure gauge
Water temperature (t)	°C	Thermometer

Table 2 Average values and standard errors of test results in pumping plants (continued on page 12)

NM kW	Properties of pumping plants										Performance of pumping plants										Energy usage of pumping plants				
	Nr.	Well Nr.	D (")	L m	M kg	DD m	Q L/s	NI kW	SL m	PWL m	P bar	TDH m	Δ m per L/s	AP %	PR %	DE MJ m ⁻³	IE MJ m ⁻³ Well	Pump-set	TE MJ m ⁻³	SR %					
22	1	32,300	4-1/2	51.9	955.8	7.9	21.6	25.7	32.6	44.0	1.3	66.0	0.53	54	82	3.10	0.15	0.08	3.33	18					
	2	32,301	5-1/2	51.9	1,105.4	5.9	31.2	25.6	31.2	46.0	0.2	54.0	0.47	64	98	2.14	0.12	0.06	2.32	2					
	3	45,213	5-1/2	48.8	1,052.0	9.6	30.2	26.1	27.6	39.2	0.4	49.0	0.38	56	84	2.25	0.11	0.06	2.42	16					
	4	53,262	6-5/8	36.6	956.8	8.4	40.6	26.6	16.4	28.2	0.2	33.0	0.29	49	75	1.71	0.06	0.04	1.81	25					
	5	49,627	6-5/8	36.6	956.8	9.1	38.6	25.2	17.3	27.5	0.8	38.5	0.26	58	88	1.70	0.06	0.04	1.81	12					
	6	42,010	6-5/8	33.6	895.4	6.8	41.6	24.5	15.5	26.8	0.3	32.5	0.27	54	82	1.53	0.06	0.04	1.63	18					
	7	42,014	6-5/8	33.6	895.4	7.1	40.2	25.3	15.9	26.5	0.4	33.0	0.26	51	78	1.64	0.06	0.04	1.74	22					
	8	42,020	6-5/8	24.4	711.2	8.4	58.3	24.6	8.2	16.0	0.1	21.0	0.13	49	74	1.10	0.04	0.02	1.16	26					
	9	42,008	6-5/8	30.5	834.0	6.0	47.9	24.6	12.6	24.5	0.5	32.6	0.25	62	94	1.34	0.05	0.03	1.42	6					
	10	42,015	6-5/8	24.4	711.2	5.5	49.6	25.3	8.4	18.9	1.1	33.1	0.21	64	96	1.33	0.05	0.03	1.40	4					
	11	51,858	6-5/8	18.3	588.4	3.1	60.5	25.8	8.9	15.2	0.5	24.0	0.10	55	84	1.11	0.04	0.02	1.17	16					
	12	46,283	5-1/2	45.8	998.6	8.9	28.9	25.4	24.6	36.9	0.7	49.0	0.43	55	83	2.29	0.11	0.06	2.46	17					
Average				36.3	888.4	7.2	40.8	25.4	18.3	29.1	0.5	38.8	0.30	56	85	1.77	0.08	0.04	1.89	15					
Standard error				3.2	44.0	0.5	3.4	0.2	2.5	3.0	0.1	3.8	0.04	2.0	2.0	0.17	0.01	0.01	0.18	2.0					
30	13	46,244	6-5/8	27.5	852.6	13.5	39.5	32.6	13.0	14.0	3.3	51.0	0.03	61	82	2.16	0.07	0.04	2.25	18					
	14	41,526	4-1/2	61.0	1,157.4	6.0	22.0	35.1	25.0	55.0	0.6	76.0	1.36	47	71	4.16	0.15	0.09	4.40	29					
	15	35,384	5-1/2	61.0	1,337.5	12.5	28.0	34.7	42.0	48.5	0.5	62.0	0.23	49	74	3.23	0.11	0.08	3.42	26					
	16	13,114	6-5/8	39.7	1,098.2	4.7	51.0	32.0	29.0	35.0	0.0	42.0	0.12	66	100	1.63	0.06	0.04	1.73	0					
	17	21,822	6-5/8	33.6	975.4	17.6	48.0	35.9	8.0	16.0	1.1	33.0	0.17	43	66	1.95	0.06	0.04	2.04	34					
	18	83,373	6-5/8	21.4	729.8	3.4	47.5	36.3	9.0	18.0	1.0	32.0	0.19	41	62	1.99	0.06	0.03	2.07	38					
	19	83,289	5-1/2	51.9	1,177.4	8.4	30.1	33.3	19.0	43.5	1.3	64.5	0.81	57	97	2.88	0.09	0.07	3.04	3					
	20	18,940	6-5/8	30.5	914.0	13.5	48.5	34.3	12.0	17.0	1.2	34.5	0.10	48	73	1.84	0.06	0.03	1.93	27					
	21	14,455	6-5/8	24.4	791.2	6.6	58.0	37.6	13.5	17.8	0.1	24.9	0.07	38	57	1.69	0.05	0.02	1.76	43					
	22	30,266	6-5/8	42.7	1,159.6	14.7	38.0	36.5	21.0	28.0	1.1	44.0	0.18	45	68	2.50	0.09	0.05	2.64	32					
	23	21,974	6-5/8	39.7	1,098.2	16.7	40.0	33.0	21.0	23.0	2.2	50.5	0.05	60	91	2.15	0.09	0.05	2.28	9					
	24	19,157	6-5/8	48.8	1,282.3	17.8	41.0	32.3	25.0	31.0	1.4	50.6	0.15	63	95	2.05	0.07	0.05	2.18	5					
	25	46,380	6-5/8	36.6	1,036.8	14.6	40.5	36.7	16.0	22.0	1.0	37.0	0.15	40	61	2.36	0.07	0.04	2.48	39					
	26	42,282	5-1/2	61.0	1,337.5	25.5	30.0	34.8	11.0	35.5	1.5	60.5	0.82	51	77	3.02	0.13	0.08	3.23	23					
	27	42,283	5-1/2	45.8	1,070.6	9.3	31.0	36.7	11.0	36.5	0.3	47.3	0.82	39	59	3.08	0.12	0.06	3.26	41					
	28	51,632	5-1/2	58.0	1,284.1	9.5	28.0	35.1	35.0	48.5	0.2	58.2	0.48	46	69	3.26	0.14	0.08	3.48	31					
	29	30,468	6-5/8	33.6	975.4	8.6	42.0	34.0	17.0	25.0	1.5	44.5	0.19	54	82	2.11	0.07	0.04	2.23	18					
	30	10,027	6-5/8	24.4	791.2	9.4	52.0	34.0	12.0	15.0	1.5	35.0	0.06	52	80	1.70	0.06	0.03	1.79	20					
	31	47,836	6-5/8	51.9	1,343.7	13.9	36.9	32.6	29.0	38.0	1.2	55.0	0.24	61	92	2.30	0.10	0.06	2.47	8					
	32	53,972	6-5/8	51.9	1,343.7	26.9	39.2	33.2	15.0	25.0	1.5	45.5	0.26	53	80	2.20	0.09	0.06	2.36	20					
	33	31,771	6-5/8	51.9	1,343.7	14.9	40.1	33.7	32.0	37.0	0.6	48.9	0.12	57	86	2.19	0.09	0.06	2.34	14					
	34	26,938	6-5/8	42.7	1,159.6	8.7	40.0	34.7	30.0	34.0	0.4	43.2	0.10	49	74	2.26	0.09	0.05	2.40	26					
	35	30,044	6-5/8	48.8	1,282.3	16.8	40.6	32.8	28.0	32.0	1.2	50.0	0.10	61	92	2.09	0.10	0.06	2.25	8					
	36	47,884	5-1/2	64.1	1,390.9	13.1	29.2	34.0	45.0	51.0	0.2	62.5	0.21	53	80	3.03	0.16	0.08	3.27	20					
	37	55,755	6-5/8	39.7	1,098.2	2.7	40.6	32.3	28.0	37.0	0.8	50.3	0.22	62	94	2.07	0.10	0.05	2.22	6					

Table 2 Average values and standard errors of test results in pumping plants (continued from page 11)

NM kW	Properties of pumping plants						Performance of pumping plants										Energy usage of pumping plants				
	Nr.	Well Nr.	D (")	L m	M kg	DD m	Q L/s	NI kW	SL m	PWL m	P bar	TDH m	Δ m per L/s	AP %	PR %	DE MJ m ⁻³	IE MJ m ⁻³ Well	Pump-set	TE MJ m ⁻³	SR %	
30	38	21,018	6-5/8	39.7	1,098.2	10.7	39.2	35.8	14.0	29.0	0.4	38.0	0.38	41	62	2.38	0.08	0.05	2.51	38	
	39	24,938	5-1/2	58.0	1,284.1	15.0	28.9	34.3	31.0	43.0	0.9	60.0	0.42	50	75	3.09	0.16	0.08	3.33	25	
	40	46,399	4-1/2	79.3	1,432.7	23.3	19.6	36.2	36.0	56.0	0.4	75.0	1.02	40	60	4.81	0.23	0.13	5.17	40	
	41	47,704	6-5/8	33.6	975.4	13.6	59.6	34.7	13.0	20.0	0.0	28.0	0.12	47	71	1.52	0.04	0.03	1.59	29	
	42	51,259	5-1/2	48.8	1,124.0	2.8	28.9	34.3	38.0	46.0	0.7	60.0	0.28	50	75	3.09	0.12	0.07	3.28	25	
	43	18,668	6-5/8	48.8	1,282.3	8.8	40.0	33.3	33.0	40.0	0.1	47.0	0.18	55	84	2.17	0.08	0.06	2.31	16	
	Average				45.2	1,136.4	12.3	38.6	34.4	23.0	32.8	0.9	48.7	0.31	51	77	2.48	0.10	0.06	2.64	23
	Standard error				2.4	34.5	1.1	1.7	0.3	1.9	2.2	0.1	2.3	0.06	1.0	2.0	0.13	0.01	0.00	0.14	2
	37	44	41,531	6-5/8	54.9	1,475.1	18.9	39.5	39.0	22.0	36.0	2.0	61.0	0.35	61	92	2.57	0.08	0.07	2.71	8
		45	41,533	6-5/8	36.6	1,106.8	11.6	49.5	43.3	22.0	25.0	0.9	39.0	0.06	44	66	2.28	0.05	0.04	2.37	34
46		13,097	8-5/8	36.6	1,450.1	9.6	49.2	47.7	23.0	27.0	0.9	38.6	0.08	44	66	2.26	0.05	0.05	2.36	34	
47		47,879	6-5/8	36.6	1,106.8	6.6	50.3	43.7	27.0	30.0	0.3	38.5	0.06	43	66	2.26	0.05	0.04	2.36	34	
48		53,262	6-5/8	45.8	1,290.9	10.8	41.1	40.3	21.0	35.0	1.7	57.0	0.34	57	86	2.55	0.07	0.05	2.68	14	
49		53,260	5-1/2	51.9	1,610.4	5.9	31.0	39.4	15.0	46.0	2.5	78.5	1.00	61	92	3.31	0.12	0.09	3.52	8	
50		32,298	6-5/8	39.7	1,168.2	28.7	60.5	39.5	6.0	11.0	2.2	41.0	0.08	62	93	1.70	0.04	0.03	1.77	7	
51		46,585	5-1/2	73.2	1,984.0	26.2	29.6	39.8	28.0	47.0	2.3	79.0	0.64	58	87	3.50	0.13	0.12	3.75	13	
52		39,272	6-5/8	54.9	1,475.1	12.9	39.8	41.8	41.0	42.0	1.4	61.0	0.03	57	86	2.73	0.09	0.06	2.89	14	
53		19,155	6-5/8	45.8	1,290.9	7.8	38.5	40.4	28.0	38.0	2.3	66.0	0.26	62	93	2.73	0.08	0.06	2.88	7	
54		36,240	6-5/8	36.6	1,106.8	10.6	49.8	43.2	13.0	26.0	0.6	37.0	0.26	42	63	2.26	0.05	0.04	2.35	37	
55		25,135	6-5/8	54.9	1,475.1	10.9	38.9	40.4	40.0	44.0	1.7	66.0	0.10	62	94	2.71	0.09	0.07	2.87	6	
56		52,681	6-5/8	36.6	1,106.8	8.6	37.8	42.3	14.0	28.0	2.1	53.0	0.37	46	70	2.92	0.07	0.05	3.04	30	
57		52,680	6-5/8	36.6	1,106.8	7.6	39.6	44.2	15.0	29.0	0.8	45.0	0.35	40	60	2.90	0.07	0.05	3.02	40	
58		53,142	8-5/8	51.9	1,884.7	19.9	40.2	40.4	20.0	32.0	2.8	63.0	0.30	61	93	2.62	0.07	0.08	2.77	7	
59		30,191	6-5/8	45.8	1,290.9	7.8	50.0	39.8	33.0	38.0	1.4	58.0	0.10	72	108	2.07	0.07	0.05	2.18	-8	
60		10,024	6-5/8	30.5	984.0	8.5	50.1	45.7	16.0	22.0	0.6	33.0	0.12	35	54	2.37	0.05	0.03	2.46	46	
61		43,400	4-1/2	97.6	1,763.9	21.6	21.5	44.1	59.0	76.0	0.3	98.2	0.79	47	71	5.34	0.22	0.14	5.70	29	
62		26,933	6-5/8	58.0	1,536.5	24.0	40.2	39.6	33.0	34.0	2.6	65.5	0.02	65	99	2.56	0.07	0.07	2.71	1	
63		51,656	6-5/8	42.7	1,229.6	0.7	40.3	40.0	32.0	42.0	1.7	63.2	0.25	62	95	2.58	0.09	0.05	2.72	5	
64		54,287	6-5/8	51.9	1,413.7	2.9	40.0	40.5	45.0	49.0	1.1	65.4	0.10	63	96	2.64	0.10	0.06	2.80	4	
65		38,313	5-1/2	70.2	1,930.6	15.2	30.2	41.5	38.0	55.0	0.7	70.5	0.56	50	76	3.58	0.14	0.11	3.83	24	
66		21,027	6-5/8	42.7	1,229.6	13.7	40.0	40.9	19.0	29.0	1.8	51.2	0.25	49	74	2.66	0.07	0.05	2.78	26	
67		52,538	6-5/8	45.8	1,290.9	5.8	39.8	40.8	23.0	40.0	1.8	62.3	0.43	60	90	2.67	0.08	0.06	2.81	10	
68		54,213	6-5/8	54.9	1,475.1	2.9	30.6	39.9	42.0	52.0	2.4	80.2	0.33	60	91	3.40	0.13	0.08	3.61	9	
69	11,277	6-5/8	45.8	1,290.9	13.8	50.4	43.0	25.0	32.0	0.4	42.3	0.14	49	74	2.22	0.06	0.04	2.32	26		
70	46,777	6-5/8	64.1	1,659.3	18.1	40.5	41.0	33.0	46.0	1.3	65.0	0.32	63	95	2.63	0.09	0.07	2.80	5		
71	46,770	6-5/8	64.1	1,659.3	20.1	39.6	40.5	34.0	44.0	1.5	65.2	0.25	63	95	2.66	0.09	0.07	2.83	5		
72	30,479	6-5/8	48.8	1,352.3	11.8	39.2	43.4	22.0	37.0	1.0	51.3	0.38	45	69	2.88	0.08	0.06	3.02	31		
73	49,956	6-5/8	73.2	1,843.5	21.2	30.9	42.1	41.0	52.0	1.7	73.5	0.36	53	80	3.55	0.13	0.10	3.79	20		
74	30,110	6-5/8	39.7	1,168.2	14.7	41.1	43.4	17.0	25.0	1.1	41.5	0.16	46	70	2.30	0.05	0.04	2.40	30		
75	47,930	4-1/2	97.6	1,741.3	28.6	20.6	42.6	43.0	49.0	1.5	114.5	0.29	54	82	5.39	0.16	0.12	5.67	18		

37	Average	52.0	1,421.8	13.9	40.3	41.5	27.8	38.1	1.5	60.1	0.29	54	82	2.84	0.09	0.07	2.99	18
	Standard error	2.9	48.6	1.6	1.5	0.3	2.1	2.2	0.1	3.2	0.04	2.0	2.0	0.14	0.01	0.00	0.15	2
	76	16,063	6-5/8	30.5	1,064.0	2.5	57.5	47.1	18.0	46.0	0.17	55	83	2.13	0.05	0.03	2.22	17
	77	13,104	6-5/8	36.6	1,186.8	17.6	60.5	52.7	17.0	39.0	0.03	44	67	2.27	0.04	0.03	2.34	33
	78	45,555	6-5/8	27.5	1,002.6	11.5	50.2	50.8	8.0	34.5	0.16	33	51	2.64	0.05	0.03	2.72	49
	79	41,146	5-1/2	73.2	1,686.0	18.2	26.1	54.0	46.0	127.0	0.34	60	91	5.39	0.11	0.11	5.61	9
	80	25,405	6-5/8	48.8	1,432.3	22.8	49.6	48.5	22.0	49.0	0.08	49	74	2.55	0.06	0.05	2.66	26
	81	46,587	6-5/8	48.8	1,432.3	17.8	60.1	41.8	28.0	31.0	0.05	58	88	2.07	0.06	0.04	2.18	12
	82	33,199	6-5/8	51.9	1,493.7	7.9	51.2	47.7	32.0	53.0	0.23	56	84	2.43	0.05	0.05	2.53	16
	83	43,045	6-5/8	70.2	1,862.1	9.2	39.6	48.4	54.0	71.0	0.18	57	86	3.18	0.10	0.08	3.36	14
	84	52,679	6-5/8	36.6	1,186.8	7.6	50.0	49.6	24.0	40.0	0.10	40	60	2.58	0.07	0.04	2.69	40
45	85	52,678	6-5/8	36.6	1,186.8	11.6	50.6	47.9	19.0	40.0	0.12	41	63	2.47	0.06	0.04	2.57	37
	86	51,634	6-5/8	45.8	1,370.9	9.8	48.2	52.9	29.0	53.0	0.15	47	72	2.86	0.05	0.05	2.96	28
	87	30,188	8-5/8	42.7	1,712.0	11.7	47.9	47.6	24.0	38.5	0.15	38	58	2.59	0.08	0.06	2.72	42
	88	47,829	6-5/8	51.9	1,493.7	15.9	49.9	51.5	34.0	49.0	0.04	47	71	2.69	0.05	0.05	2.79	29
	89	53,597	6-5/8	39.7	1,248.2	4.7	40.5	53.1	17.0	46.0	0.44	34	52	3.42	0.07	0.05	3.54	48
	90	31,773	6-5/8	51.9	1,493.7	15.9	50.6	48.8	27.0	53.0	0.18	54	82	2.51	0.06	0.05	2.62	18
	91	42,637	6-5/8	45.8	1,370.9	11.8	48.9	47.3	27.0	48.0	0.14	49	74	2.52	0.07	0.05	2.64	26
	92	32,592	6-5/8	48.8	1,432.3	16.8	48.8	56.2	29.0	49.0	0.06	42	63	3.00	0.05	0.05	3.10	37
	93	8,306	6-5/8	33.6	1,125.4	13.8	58.9	53.2	19.0	39.0	0.02	42	64	2.35	0.02	0.03	2.41	36
	94	20,525	6-5/8	45.6	1,370.9	13.8	50.3	47.3	31.0	46.0	0.02	48	73	2.45	0.06	0.05	2.56	27
	95	30,485	6-5/8	39.7	1,248.2	16.7	50.6	48.0	22.0	49.0	0.02	51	77	2.47	0.07	0.04	2.58	23
55	96	14,478	6-5/8	39.7	1,248.2	14.7	50.4	48.0	12.0	41.0	0.26	42	64	2.48	0.08	0.04	2.60	36
	97	43,504	6-5/8	67.1	1,800.7	18.1	40.9	50.8	37.0	71.0	0.29	56	85	3.23	0.11	0.08	3.41	15
	98	47,705	6-5/8	39.7	1,248.2	16.7	49.8	49.1	12.0	41.0	0.22	41	62	2.57	0.05	0.04	2.66	38
	99	50,391	5-1/2	58.0	1,419.1	3.5	28.6	49.3	47.0	92.0	0.26	52	79	4.49	0.12	0.09	4.70	21
	100	25,687	6-5/8	39.7	1,248.2	15.7	39.6	48.6	12.0	79.0	0.30	63	96	3.20	0.10	0.06	3.36	4
	101	41,860	4-1/2	73.2	1,460.9	2.2	22.2	52.7	49.0	135.0	0.99	56	84	6.19	0.13	0.12	6.43	16
	Average	47.0	1,377.9	12.6	47.0	50.0	26.8	34.4	1.6	56.08	0.19	49	73	2.95	0.07	0.06	3.08	27
	Standard error	2.5	42.5	1.1	1.9	0.5	2.4	2.7	0.3	5.0	0.04	2.0	2.0	0.19	0.01	0.00	0.20	2
	102	51,343	5-1/2	54.9	1,455.8	8.9	28.9	60.1	32.0	105.0	0.48	50	75	5.41	0.13	0.09	5.63	25
	103	51,344	5-1/2	51.9	1,402.4	8.9	29.5	59.7	29.0	113.0	0.47	55	83	5.27	0.12	0.08	5.47	17
	104	51,345	5-1/2	61.0	1,562.5	9.0	30.0	58.1	37.5	104.0	0.48	53	80	5.05	0.14	0.09	5.27	20
105	51,351	5-1/2	51.9	1,402.4	10.4	30.5	59.7	30.5	110.0	0.36	55	83	5.10	0.11	0.08	5.29	17	
106	51,353	5-1/2	48.8	1,349.0	9.8	24.6	57.1	24.5	114.0	0.59	48	73	6.05	0.13	0.10	6.28	27	
107	43,012	6-5/8	61.0	1,562.5	11.2	41.0	59.4	30.6	62.0	0.47	42	64	3.77	0.10	0.07	3.94	36	
108	43,011	6-5/8	81.0	1,777.9	12.5	38.9	57.9	31.5	83.0	0.44	42	83	3.87	0.10	0.08	4.05	17	
109	46,900	6-5/8	58.0	1,716.5	7.0	48.0	56.7	36.8	62.0	0.30	51	78	3.08	0.08	0.06	3.22	22	
110	46,591	6-5/8	61.0	1,777.9	13.7	49.0	58.0	30.6	61.0	0.28	51	77	3.08	0.09	0.06	3.24	23	
Average	56.6	1,556.3	10.1	35.6	58.5	31.8	46.5	3.6	88.2	0.43	50	75	4.52	0.11	0.08	4.71	25	
Standard error	1.6	55.8	0.7	3.0	0.4	1.3	1.5	0.9	8.4	0.03	2.0	2.0	0.36	0.01	0.00	0.37	2	
Overall average	47.6	1,283.8	12.1	41.1	41.1	25.5	35.4	1.4	56.1	0.28	52	78	2.79	0.09	0.06	2.93	22	
Overall standard error	1.4	27.6	0.6	1.0	0.9	1.1	1.2	0.1	2.1	0.02	1.0	1.0	0.10	0.00	0.00	0.10	1	
Total	5,232	141,219	1,334	4,517	4,528	2,803	3,899	156	6,171	31	-	-	-	306	10	7	323	-

energy was assumed. Therefore, if the provided irrigation water unit energy consumption was low, plant production was high to the same degree. This has more importance for Turkey, which is an agriculture country in arid and semiarid region. Total energy consumed for supplying water for the irrigation pumps consists of two components; direct and indirect energy (Eqn. 10) (Kaltschmit & Moersnhner, 1995). The specific direct energy component for supplying water was calculated by dividing electrical power consumed from network to system flow rate (Eqn. 8). The indirect energy component was calculated by addition of the specific energy consumption of drilling a deep well and energy for manufacturing the pump-set. In this study, labour energy was negligible. Below equations were used for determining the energy component.

$$DE=(NI/(3.6*Q))*E_1 \dots\dots\dots(8)$$

$$IE=(WD*E_2)/n_1+(M*E_3)/n_2 \dots\dots(9)$$

$$TE=DE+IE \dots\dots\dots(10)$$

In Turkey, the efficiency of production and transportation of electrical energy is 38.4 % (WEC, 1990). Equivalent unit of electrical energy was taken as E_1 9.375 MJ kW h⁻¹. E_2 is the specific energy consumption of well drilling and is assumed to be 1,764.7 MJ m⁻¹ (Çalisir et al., 2001). E_3 is the energy equivalent,

which is consumed to produce the machine and was used as 100.7 MJ kg⁻¹ (Bridges & Smith, 1979), and n_1 and n_2 are average design life of the drilling well and pump-set. Both of them were assumed as 16,000 h life⁻¹ (USDA, 1959 and Karassik et al., 1986).

The energy saving rating of pumping plants (SR) was determined by Equation 11 below (Hay et al., 1984; New, 1986; USDA, 1997).

$$SR=100-PR \dots\dots\dots(11)$$

Results and Discussion

One hundred submersible deep well irrigation pumping plants were tested and the results of plant properties, performance and energy usage are given in **Table 2**.

Generally Properties of Pumping Plants

About 72.7 %, 19.1 %, 5.5 % and 2.7 % relative distribution was examined for column pipe with diameter 6-5/8" 5-1/2", 4-1/2" and 8-5/8", respectively. Total mass for pumping plants, column pipe length, static level, pumping diving depth and specific draw down ranged between 711.2-1,930.6 kg, 18.3-97.6 m, 8.0-59.0 m, 0.7-29.0 m and 0.03-1.02 m per L/s, respectively. Overall averages were de-

termined as 1,283.8 ± 27.6 kg, 47.6 ± 1.4 m, 25.5 ± 1.1 m, 12.1 ± 0.6 m and 0.28 ± 0.02, respectively. The total mass for per pumping plants increased when the pumping plant motor power increased. Specific drawdown and pump diving depth with respect to motor power groups distributions are given in **Fig. 1** and **Fig. 2**. The specific draw down range was 0.21-0.40 m per L/s for well number 39. It is expressed that the feeding situation of the well for which specific draw down is small is good for agricultural irrigation.

In the region, 49 % were 11 to 20 m and 38 percent were 5 to 10 m of the total pumping plants that were set up. According to optimum diving depth of 5 m, pumps were placed at a greater depth at 89 % of the plants. This situation caused much more material to be used and more energy loss. As a result, an accurate determination of well characteristics could not be made and decreasing concern depending on the time the water level could be shown.

Performance Evaluation of Pumping Plants

The flow rate of pumping plants was varied from 20.4 to 60.5 L/s depending on discharge pipe diameter while the actual performance of plants varied from 30 to 65 %.

Fig. 1 Distribution of specific drawdown in pumping plants

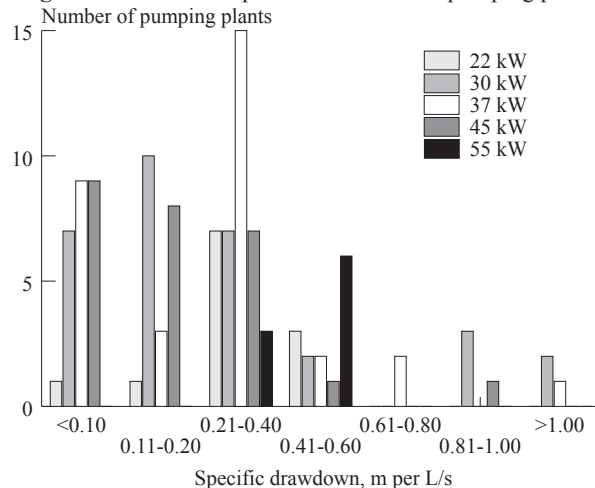
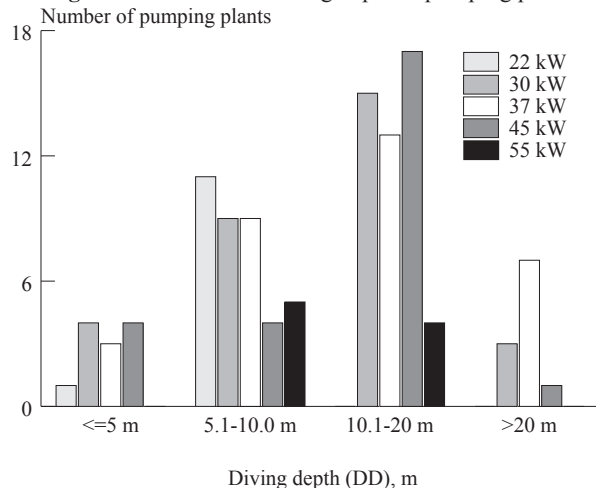

Fig. 2 Distribution of driving depth in pumping plants



Actual performance at 46 plants ranged from 46 to 55 % (Fig. 3). Actual performance of all plants was about 50 ± 2 . The number of plants with actual performances below 40 % and above 65 % were 6 and 2, respectively. Similar results were reported by Saqib & Khan, (1993); Conlon et al., (1999); Hla & Scherer, (2001) ve Loftis & Miles, (2001).

According to NPC, a histogram of performance rating is presented in Fig. 4. The performance ratings varied between 51 to 108 %. For these conditions, NPC criteria were obtained at two plants. The performance rating of all plants were found to be 78 ± 2 %. On the other hand, there was a saving potential of 22 % in research plants.

This result, if total motor power of the plants and an annual operating time of $1,278.5 \pm 27$ h are considered, appears to be a problem that could be fixed immediately (Çalışir et al., 2002). For this, better system design, correct pump and motor selection, usage of current pumps more efficiently and a correct checking program should be made.

Evaluation of Energy Usage in Pumping Plants

At plants under the test, the energy consumption varied between the values of 1.10 to 6.05 MJ m^{-3} ,

and overall average direct energy consumption was calculated as $2.79 \pm 0.10 \text{ MJ m}^{-3}$. Direct energy consumption increased as the motor power increased (Table 2). Direct energy is 95.22 % of total energy consumption. For the entire plant, the overall average indirect energy (consisting of installation of drilling well of $0.11 \pm 0.01 \text{ MJ m}^{-3}$ and pump-set set up energy of $0.08 \pm 0.01 \text{ MJ m}^{-3}$) was calculated as $0.19 (0.01 \text{ MJ m}^{-3})$. Additionally, overall average specific total energy consumption was found to be $2.93 \pm 0.10 \text{ MJ m}^{-3}$. Sloggett (1992); Hülsbergen et al. (2001); and ve Mrini et al. (2001), reported similar results for the plant that uses electrical energy for sprinkler irrigation. Distribution of specific total energy consumption over motor power is shown in Fig. 5. According to this, while specific energy consumption changed between 2.1 and 3.0 MJ m^{-3} at 58 % of all the plants, specific total energy consumption increased with increasing motor power. The relationships between specific energy consumption to motor power, flow rate and total dynamic head were shown in Figs. 6, 7 and 8, respectively. The relationships between these factors were found statistical significantly ($p < 0.05$).

Conclusions

The following conclusions can be drawn with respect to tested submersible deep well irrigation pumping plants.

- The pump diving depth was the upper of optimum level at 89 % of the plants.
- Specific draw down was less than 0.4 m per L/s at 79 % of all wells. Therefore, it is sufficient for agricultural irrigation.
- Actual performance or system efficiency of plants was determined as 50 % in all plants. Performance rating was 78 % when compared with NPC. In these conditions, there are improving possibilities for saving rating potential of 22 % at plants.
- Energy equivalent of specific irrigation water of submersible deep well pumping plants were found to have an average $2.93 \pm 0.10 \text{ MJ m}^{-3}$. As motor power increased, specific total energy consumption increased. An important energy loss occurred when absolute values of power consumed and annual operation time of plants were considered.

Notations

Δ : Specific draw down of wells, m

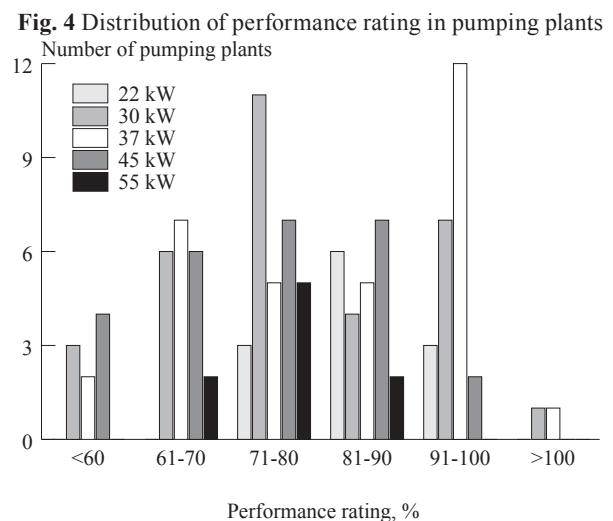
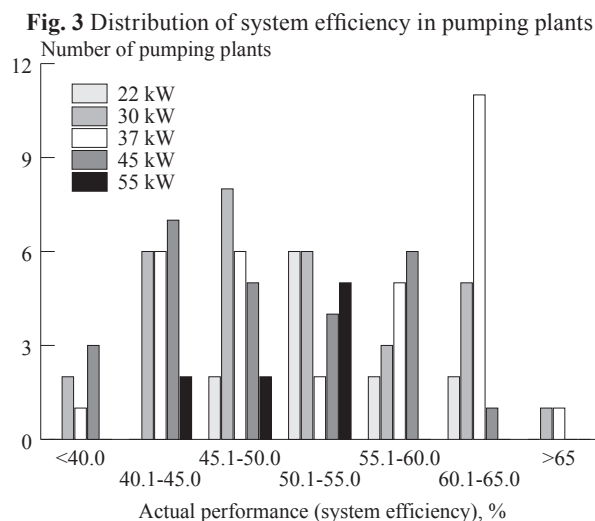

per L s⁻¹
 γ : Water density, kg L⁻¹
 AP: Actual performance or system efficiency, %
 D: Diameter of pump discharge pipe, "
 DD: Diving (submersible) depth of pump, m
 DE, Specific direct energy consumption, MJ m⁻³
 E₁: Electrical energy equivalent, MJ kWh⁻¹
 E₂: Specific Deep well drilling energy, MJ m⁻¹
 E₃: Machine manufactured energy equivalent, MJ kg⁻¹
 FL: Column pipe friction loss, m
 g: Gravity acceleration, m s⁻²
 IE: Specific indirect energy consumption, MJ m⁻³
 J: Pipe hydraulic gradient, m per m
 L: Column line length, m
 M: Total mass of pump-set, kg
 n₁: Design life of well, h
 n₂: Design life of pump-set, h
 NI: Actual electrical power consumed, kW
 NM: Submersible motor nominal power, kW
 NPC: Nebraska Performance Criteria, %
 P: Discharge pressure, bar
 PR: Performance rating, %
 PWL: Pumping water level, m
 Q: Flow rate, L s⁻¹

SL: Static level, m
 SR: Energy saving potential rating, %
 t: Water temperature, °C
 TDH: Total dynamic head, m
 TE: Specific total energy consumption, MJ m⁻³
 v: Water velocity of pump discharge pipe, m s⁻¹
 VH: Velocity head, m
 WD: Well depth, m

REFERENCES

- Anonymous 2002. Registered of Konya Regional Directorate of State Meteorology Works (SMW) Konya/Turkey.
 Anonymous 2000. Registered of 4th Regional Directorate of State Hydraulic Works (SHW), Konya Turkey.
 Bridges, T. C. and E. M. Smith 1979. A method for determining the total energy input for agricultural practices. Transaction of the ASAE. 0001-2351/79/2204. pp. 781-784.
 Conlon, T., G. Weisbrod, and S. Samiullah. 1999. We've Been Testing Water Pumps For Years-Has their Efficiency Changed? Proceedings of the April ACEEE Summer Study of Energy Efficiency in Industry, California. Cooperative Extension Service - EC 84-725, USA.
 Çalışır, S., T. Eryılmaz, and A. Erkol. 2001. Determination of specific energy consumption on drilling of water wells, Journal of Agricultural of Faculty University of Selçuk, ISSN: 1300-5774, 15(27): 145-152.
 Çalışır, S., T. Marakoglu, and M. U. Yildiz. 2002. Annual usage of deep well irrigation pumping plants in Çumra/Konya, Journal of Agricultural of Faculty, University of Selçuk, ISSN: 1300-5774, 16(30): 84-87.
 Diepenbrock, W., B. Pelzer, and J. Radtke. 1995. Energiebilanz im Ackerbaubetrieb, Kuratorium für Technik und Bauwesen in der Landwirtschaft (KTLB). Darmstadt, Arbeitspaper 211, Landwirtschaftsverlag Münster-Hiltrup, 1995.
 Hansen, D. J. 1974. Laboratory testing of centrifugal and vertical turbine pumps, ASHRAE Transactions, (80)2: 448-455.
 Hanson, B. 1994. Irrigation pumping plants. On-Farm Irrigation, Water Management Handbook Series. Publication number 93-94, University of California. Davis.
 Hay, D., R. M. Schroeder, and T. Dorn. 1984. Pumping Plant Repair Feasibility. Nebraska

Fig. 5 Distribution of specific total energy consumption in pumping plants

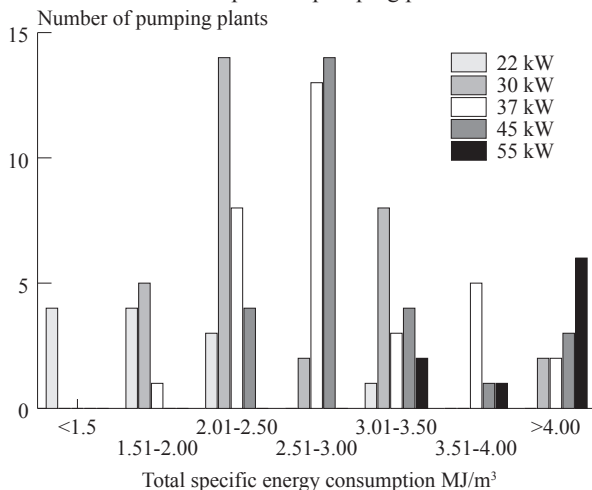
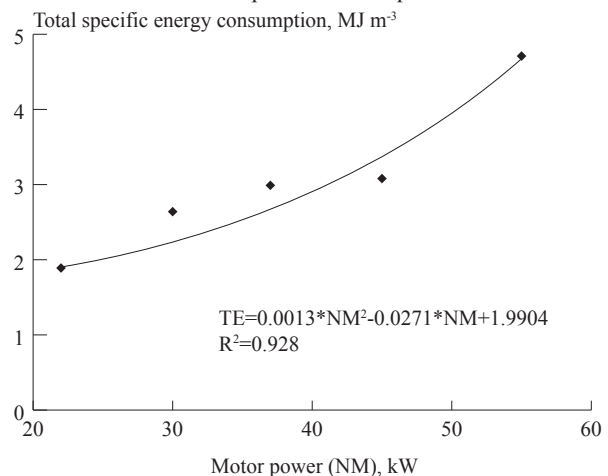

Fig. 6 Effect on specific total energy consumption of motor power



- Heyland, K. U. and S. Solansky. 1979. Energieeinsatz und Energieumsetzung im Bereich der Pflanzenproduktion, Ber. Landw., (195): 15-30.
- Hla, A. K. and T. F. Scherer. 2001. Operating efficiencies of irrigation pumping plants, paper number 01-2090, Extension Service North Dakota State University USA.
- Hülsbergen, K., J. B. Feil, S. Biermann, G. W. Rathke, W. D. Kalk, and W. Diepenbrock. 2001. A method of energy balancing in crop production and its application in a long-term fertilizer trial, Agriculture, Ecosystems and Environment, (86): 303-321.
- Kaltschmitt, M. and A. Reinhardt. 1995. Nachwachsende Energieträger. Grundlagen, Verfahren, Karassik, I. J., W. C. Krutzsch, W. H. Fraser, and J. P. Messina. 1986. Pump Handbook, Second edition, New York.
- Kosyna, G. 1984. Taucmotoren und moderne Pumpentechnik. World Pumps, p. 153-157.
- Loftis, J. C. and D. L. Miles. 2001. Irrigation Pumping Plant Efficiency, Colorado State University Crop Series, No: 4.712.
- McClave, J. T. and P. G. Benson. 1988. Statistics for business and economics (4th Edn.). Dellon Pub. Co., San Francisco. CA.
- Moerschner, J., B. Gerowitt, and W. Lücke. 1997. Abbildung energetischer Effekte beim Vergleich von Ackerbausystemen mit geringen Intensitätsunterschieden, VDLUFA-Schriftenreihe 46, VDLUFA-Verlag, Darmstadt, p. 471-474.
- Mrini, M., F. Senhaji, and D. Pimentel. 2001. Energy Analysis of Sugarcane Production in Morocco. Environment, Development and Sustainability, (3): 109-126.
- New, L. 1986. Pumping plant Energy use and potential savings, Water Resources Engineering (2).
- Ökologische Bilanzierung. Vieweg Verlag, Braunschweig/Wiesbaden.
- Saqib, G. S. and S. Khan. 1993. Performance evaluation of deep well turbine pumps, Journal Agriculture Engineering Research (JAER), p.165-175.
- Schulz, H. 1977. Die Pumpen (Arbeitsweise, Berechnung, Konstruktion). Springer Verlag. Berlin.
- Sloggett, G. 1992. Estimating energy use in world irrigation. (Edited by RC Fluck, Energy in Farm Production), Chapter 14, pp. 203-218. New York.
- Smil, V. 1983. Energy analysis and agriculture, An Application to US, Corn Production, Westview Press Boulder, Colorado.
- State Hydraulic Works (SHW). 1997. Statistics Publication, General Directorate of State Hydraulic Works, Ankara, Turkey.
- State Institute of Statistics (SIS). 2001. For 1999 year Agricultural structure (production, price, value), Prime Ministry Republic of Turkey, Ankara, Turkey.
- USDA (United States Department of Agriculture), Natural Resources Conservation Service (NRCS). 1959. Irrigation pumping plants. National Engineering Handbook. 210-vi-NEH-15, Section 15, Chapter 8.
- USDA (United States Department of Agriculture), Natural Resources Conservation Service (NRCS). 1997. Energy use and conservation. National Engineering Handbook. 210-vi-NEH, Part. 652. Irrigation Guide, Chapter 12.
- World Energy Council (WEC), Turkish National Committee (TNC). 1990. Energy statistics. Turkey 5. Energy Congress. s. 219. Ankara, Turkey.
- Yaldiz, O., H. H. Öztürk, Y. Zeren, and A. Başçetinçelik. 1990. Usage energy in crop production of Turkey, Akdeniz University, Journal of Agricultural Faculty, 3(1-2): 51-62, Antalya, Turkey.



Fig. 7 Effect on specific total energy consumption of flow rate

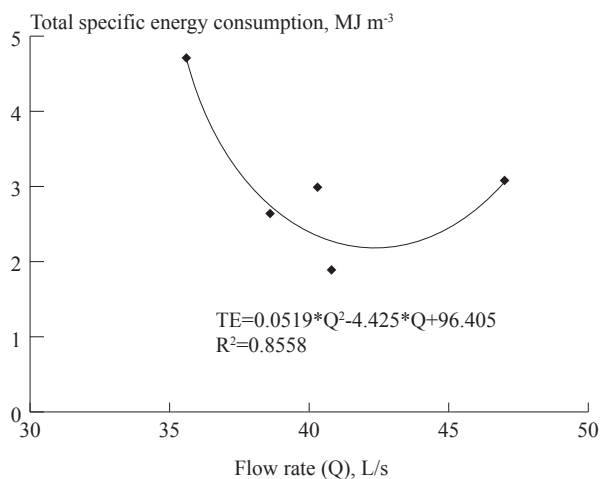
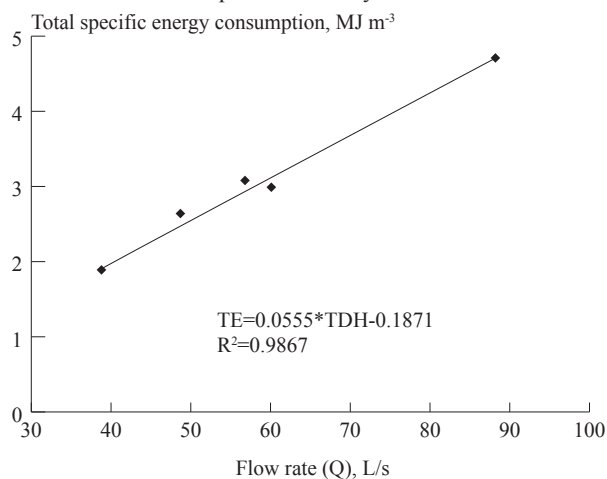

Fig. 8 Effect on specific total energy consumption of total dynamic head



Status of Farm Mechanization in Nalanda District of Bihar



by
V. B. Shambhu
Scientist
Central Research Institute for Jute
and Allied Fibres,
Barrackpore - 700 120, West Bengal
INDIA
vbs9605@yahoo.co.in

R. B. Ram
Professor and Dean (P.G.)
Rajendra Agricultural University,
Pusa - 848 125, Bihar
INDIA

Abstract

The pace of farm mechanization is very slow in Bihar state as compared to many advanced states of the country. A study was undertaken to identify the status of farm mechanization in Nalanda District of Bihar. A survey was conducted in three blocks of the district having different geographical areas. The only manually operated improved equipment were sprayers, dusters and chaff cutters numbering 27, 9 and 470 per thousand hectare, respectively. In the case of bullock drawn equipment, cultivator, bullock carts and cane crushers were 103, 22 and 9 units per thousand hectare, respectively. The average number of tractors per thousand hectare area was 17 which was higher than other districts of the state. Only cultivators and trailers were used with the tractor. The number of tractor operated threshers were eight whereas other power operated threshers were 203 per thousand hectare area. The bottleneck in mechanization was due to lack of extension programmes, availability of equipment, farm roads and consolidation of land holdings.

Introduction

It has been well realized all over the world that in order to meet the food requirements of the rapid growing population and rapid industrialization, the mechanization of agriculture is inescapable. The package of modern technology includes the use of more efficient and economical farm implements and machineries and suitable forms of farm power. Modernization requires appropriate machinery for ensuring timely field operations and effective application of various crop production inputs utilizing human, animal and mechanical power sources. Equipment for tillage sowing, irrigation, plant protection, harvesting and post harvest operations have widely been accepted by farmers. This study was conducted to assess farm mechanization in Nalanda district of Bihar.

Ray (1993) studied the status of farm mechanization and constraints in 1987. He reported that the use of traditional implements were more popular than the improved implement and machinery. He also reported that the majority of farmers were small and could rarely afford to pur-

chase huge and costly agricultural implements and machinery. Patel (1981) studied farm mechanization in India. He observed that per unit cost of operation declined sharply under mechanization and there was time saving in tillage operation. He also reported that mechanized farms had more labour hour use than the non-mechanized farms. Dash et al. (1988) studied constraints in the use of agricultural implements and machinery in the state of Orissa. They observed that mechanization in agriculture was not up to mark because of problems which were mostly social, economical and technical in nature. Kumar et al. (1991) investigated constraints on the use of agricultural implements and machinery in the state of Rajasthan, India. They reported that problems were mainly social, economical, and technical. They also recommend how these problems might be overcome. Mittal et al. (1989) reported that the production and availability of food crops can be increased by about 40 per cent in the Punjab state through the farm mechanization of sowing, intensive cropping, plant protection, post harvest practices and reclamation of cultural wastes.

Materials and Methods

Stratified multi-stage random sampling design was adopted for collection of data with regard to known status of farm implements and machinery use in Nalanda district of Bihar. Three blocks from the district were selected randomly for this survey. Selection of blocks was done by an implement and machinery index, which was prepared by giving specified priority values to different farm implement and machinery.

On the basis of the implement and machinery index the blocks of the district were enlisted in ascending order. One block was selected randomly from above the average index value, one from below the average index value and one from average value. Thus, the three blocks selected were Sarmera, Rajgir and Ekangar Sarai. Three villages were taken from each block.

Thirty six farm families from different farm categories (marginal, small, medium size and large farmers) owning improved implements and machinery of nine selected villages were contacted for collecting data (through comprehensive proforma). The proforma was developed

to provide necessary information regarding village and cultivators. Information about a village included demographic details of house hold, inventory of implement and machinery, distribution and availability of power source, land utilization pattern, irrigation structure and cropping pattern (rotation). Information regarding cultivator included family description, land utilization pattern, mode of irrigation, farm machinery and implement owned, cropping pattern, and operation wise power utilization. This included availability, demand and deficit of various power sources for crop production for different farm categories in the study area. The important crop rotations were Paddy-Wheat or Paddy-Onion and Moong.

Results and Discussion

Status of Improved Implements and Machinery in Use

For the purpose of this study, information regarding availability of improved implements and machineries operated by various power sources in the selected villages were collected and presented below:

Table 1 Status of manually operated implements and machineries used in selected blocks of Nalanda district (based on sample survey)

No. of farm implements and machineries per 1000 ha cultivated area					
Sl. No.	Name of farm implement/machinery	Ekangar Sarai block	Sarmera block	Rajgir block	District average
1	Sprayer	41.72	22.07	17.39	27.06
2	Duster	4.91	11.03	10.43	8.79
3	Chaff cutter	520.25	593.10	295.65	469.67
4	Pedal paddy thresher	Nil	Nil	Nil	Nil
5	Hand maize sheller	Nil	Nil	Nil	Nil

Table 2 Status of bullock drawn implements and machineries uses in selected blocks of Nalanda district (based on sample survey)

No. of farm implements and machineries per 1000 ha cultivated area					
Sl. No.	Name of farm implement/machinery	Ekangar Sarai block	Sarmera block	Rajgir block	District average
1	Desi plough	453.90	310.34	321.74	361.99
2	Cultivator	73.62	131.03	104.35	103.00
3	Planker	319.02	208.69	263.10	263.6
4	Bullock cart	39.26	13.79	17.39	22.15
5	Cane crusher	12.27	8.28	5.22	8.59

Status of Manually Operated Implement and Machinery in Use

Table 1 indicates that the use of plant protection equipment was very low, i.e. less than 60 per thousand hectare including sprayers (manually and power operated) and dusters as compared to the national standard of 200 units per 1000 hectares. It was observed that Ekangar Sarai block had 42 sprayers per 1000 ha whereas Sarmera and Rajgir blocks had only 22 and 17 sprayers, respectively. This difference was due to the fact that the area of serial crops in Ekangar Sarai block was more as compared to other blocks. On the contrary, Ekangar Sarai block had only 5 dusters per 1000 ha as compared to Sarmera, Rajgir blocks. This was because the onion growing area was observed to be greater with respect to Ekangar Sarai block. The average number of chaff cutters in use in the district was 470 and in different blocks varied from 296 to 593 per 1000 ha cultivated area. It was observed that the blocks with a lower number of chaff cutters had low cattle population on one hand and had high grazing area on the other hand due to the presence of hillocks in the block. Surprisingly, no pedal paddy threshers and hand maize shellers were observed in all three blocks. Paddy threshing was observed to be still in the primitive stage.

Status of Animal Operated Implements and Machinery in Use

It is clear from **Table 2** that the position of implement and machinery use was very poor except in case of the desi plough. The availability of M.B. plough, disc plough, disc harrow, olpad thresher, seed-drill, ridger and puddler was almost nil in the entire district. It was observed that the cultivator in all three blocks were being used as the primary tillage implement instead of secondary tillage. It was observed that Ekangar Sarai block had 454 desi ploughs and 319 plankers per 1000 ha whereas Sarmera and Rajgir blocks

had 310 desi ploughs, 209 plankers and 322 desi ploughs and 263 plankers, respectively. This variation was due to the fact that the paddy growing area in Ekangar Sarai block was highest among the three. Then comes Rajgir block followed by Sarmera block. The number of cultivators in Ekangar Sarai block was 74 per 1000 ha where, as in Sarmera and Rajgir blocks, there were 131 and 104 per 1000 ha, respectively due to higher pulse growing area.

The number of bullock carts in Ekangar Sarai, Sarmera and Rajgir blocks were found to be 39, 14 and 17 per 1000 ha, respectively. Ekangar Sarai block had more carts because it had more roads as compared to Sarmera and Rajgir blocks. The number of cane crushers was more in Ekangar Sarai block with respect to Sarmera and Rajgir due to higher sugarcane area in Ekangar Sarai block.

Status of Tractor and Tractor Drawn Implement in Use

The sample survey data given in **Table 3** clearly indicate that the number of tractors per 1000 ha cultivated area available in different block varied from 15.17 to 19.65 with the state average of 8.34.

The tractor drawn primary tillage implement like M.B. ploughs, disc ploughs etc. were almost non-existent throughout the district except in Ekangar Sarai where 5 ploughs per 1000 ha were available. It was observed that the tractor drawn cultivator was the only implement available with almost every tractor owner. The disc harrow which is one of the most useful secondary tillage implements was almost nil throughout the district. The other seed bed preparation implements like levellers, puddlers, ridgers, etc. were almost non-existent throughout the district except puddlers was a rare implement found with the tractors in the entire district. The trailer was another equipment which was very popular and owned by almost all tractor own-

ers. The use of other tractor drawn implements like seed drill/seed cum fertilizer drill, reaper, potato planter, digger and transplanter. were nil.

Ekangar Sarai block had 20 tractors per 1000 ha where as Sarmera and Rajgir blocks had 15 and 16 tractors, respectively. This difference was due to the fact that Ekangar Sarai block had more roads as compared to Sarmera and Rajgir blocks. Almost all tractor owners had a cultivator and trailer except M.B. Plough, disc plough and cage wheel. Ekangar Sarai block had 17 cage wheels and 12 puddlers per 1000 ha whereas Sarmera and Rajgir blocks had 6 cage wheels, 7 puddlers and 10 cage wheels, 10 puddlers, respectively. This variation was due to the fact that the paddy growing area in Ekangar Sarai block was highest among the three; then comes block followed by Rajgir then Sarmera block. The power tiller in Sarmera block was almost non-existent. It was observed that Ekangar Sarai block had 5 power tillers per 1000 ha where as Rajgir block had 9 power tillers per 1000 ha.

Status of Power Operated Implements and Machinery in Use

The centrifugal pumps were the most common power operated irrigation equipment used for under ground water pumping as well as lifting of water from shallow water sources like wells and ponds throughout the district. The availability of these pumps were highest in Ekangar Sarai

block which gave an average command area of approximately 2 ha per unit. Sarmera and Rajgir blocks had 4.4 and 2.45 ha per unit, respectively. There was sufficient scope to increase the number of pumping sets in both the Sarmera and Rajgir blocks. This was because area of onion cultivation was observed to be increasing slowly which is a cash crop and requires higher irrigation.

The adoption of power wheat threshers and rice hullers were quite satisfactory so far as number of units was concerned but most of them did not meet the prescribed standard causing serious accidents every year. The paddy as well as multicrop threshers were not catching up causing undue delay and wastage of crops due to prevailing slow and inefficient threshing. It was observed that only those power operated threshers were available which were being fabricated by the local blacksmith. It is still in a process of development. Initially it started with simple hammer type (beater type) thresher without any blower and sieve shakers. It was easy for the blacksmith to fabricate and was cost effective to suit the economy of the farmers. Local blacksmiths were not trained to fabricate improved threshers. It was easy for farmers to get repairs and also with in the skill of blacksmiths to repair them. It is hoped that in near future sieve shakers will also be available from the local blacksmith and the economy of farmers will also

Table 3 Status of tractor and tractor drawn implements and machineries uses in selected blocks of Nalanda district (based on sample survey)

No. of farm implements and machineries per 1000 ha cultivated area					
Sl. No.	Name of farm implement/machinery	Ekangar Sarai block	Sarmera block	Rajgir block	District average
1	Tractor	19.65	15.17	15.67	16.83
2	Cultivator	19.65	15.17	15.67	16.83
3	M.B. Plough	4.91	Nil	Nil	Nil
4	Disc plough/harrow	4.91	Nil	Nil	Nil
5	Trailer	19.65	15.17	15.67	16.83
6	Cage wheels (pair)	17.18	5.51	10.44	11.04
7	Thresher	7.36	9.66	6.96	7.99
8	Puddler	12.27	6.90	10.43	9.87
9	Power tiller	4.90	-	8.7	4.53

improve to purchase them. It is clear from the **Table 4** that flour mills, cane crushers and oil expellers were available in very low numbers at the village level which indicated that processing activities were not being done at village level. Area of sugarcane was very low and did not require a power operated cane crusher. The job was met by bullock drawn cane crushers so far as oil expellers were concerned. It was observed that the job was done at the nearby bazar or market. The availability of maize shellers, and winnowers were almost nil throughout the district due to low coverage and ignorance about maize shellers (**Table 4**). It was observed that Ekangar Sarai block and Rajgir block had 493 and 408 centrifugal pumps per 1000 ha, respectively, but Sarmera block had only 228 per 1000 ha.

The low number of centrifugal pumps in Sarmera block was due to the fact that area under the block remains submerged for about 3-4 months every year. Pulse crop being grown in the tal area did not require irrigation. The number of thresher in Ekangar Sarai, Sarmera and Rajgir blocks were 238, 137 and 235 per 1000 ha, respectively. The lower number of power operated threshers in Sarmera block was due to the fact that the number of tractor operated threshers were observed to be higher. Rice hullers in Ekangar Sarai, Sarmera and Rajgir blocks were 221, 123 and 161 per 1000 ha, respec-

tively. It was observed that Ekangar Sarai had a higher paddy growing area followed by Rajgir and Sarmera blocks. Flour mill in Ekangar Sarai, Sarmera and Rajgir blocks were 30, 25 and 26 per 1000 ha, respectively. It was observed that they were almost similar. It was observed that power sprayers in all three blocks were almost identical. The power sprayers in Ekangar Sarai, Sarmera and Rajgir blocks were 25, 24 and 25 per 1000 ha, respectively (**Table 4**).

Constraints in Farm Mechanization

In order to know the problems responsible for poor adoption of farm implements and machineries, 36 farm families from different farm categories were consulted to obtain their opinion in view of their vast experience in farming. Although farmers of various blocks were consulted, still their reaction or opinion were common and indicated lack of infrastructure like farm roads electricity, agricultural engineering extension programmes and the like as discussed below:

The farmers reported the various problems being faced by them in the way of adoption of most of farm implements as summarized below:

Agricultural Engineering Extension Programmes

The Agricultural Engineering Extension Programme was found to be very poor in Nalanda district. This

reflected in the awareness of farmers and use of farm implement and machinery. The data revealed that about 96 % bullock owned farmers were ignorant about improved implements, such as M.B. plough, disc harrow, seed drill, olpad thresher and ridger. Similarly about 90 % tractor owned farmers were ignorant about improved machinery and implements. About 98 % of farmers did not know about pedal paddy thresher and power/hand operated maize sheller.

There was no field demonstration or training programme with regard to improved implements. Similarly, implement manufacturers were not available except very few low quality thresher fabricators. This was due to poor extension programmes in this direction.

Non-availability of Implements

Appropriate type of implements were not available within their easy reach. There were no Local manufacturers of agricultural implements in Nalanda district. Only threshers are being fabricated by local artisan.

Small Holdings

The survey revealed that the number of marginal (below 1.0 ha), small (1.0-2.0 ha), semi medium (2.0-4.0 ha), medium (4.0-10 ha) and large (10.0 above) farmers are 241,905, 35,668, 14,835, 2,981 and 44, respectively and possessed 46.25, 24.63, 20.70, 8.09 and 0.33 % of the total cultivated area, respectively.

Again it was observed that about 92 % of land of marginal farmers, 74 % of land of small farmers, about 35 % of land of medium size farmers and about 20 % of land of large farmers were of very small size. Irregular shape of fields made it difficult to carry out field operations properly. Farmers felt that this problem could be resolved by introducing joint farming or farming on co-operative basis leading to increase in farm holding size. They were being made aware of land con-

Table 4 Status of power operated machinery used in selected blocks of Nalanda district (based on sample survey)

No. of farm implements and machineries per 1000 ha cultivated area					
Sl. No.	Name of farm implement/machinery	Ekangar Sarai block	Sarmera block	Rajgir block	District average
1	Centrifugal pump	493.25	227.58	208.70	376.51
2	Thresher	238.04	136.55	234.78	203.12
3	Rice huller	220.86	122.76	160.83	168.15
4	Flour mill	29.45	24.83	26.03	26.29
5	Cane crusher	9.82	6.90	5.22	7.31
6	Maize sheller	Nil	Nil	Nil	Nil
7	Oil expeller	4.91	4.01	3.48	4.18
8	Winnowers	Nil	Nil	Nil	Nil
9	Power sprayer	24.54	23.45	24.65	24.21

solidation by government agencies. Such consolidation could attract co-operative farming or mechanized farming. Land consolidation be done by Revenue Department in collaboration with Department of Agricultural Engineers with latest knowledge of farm roads, irrigation systems, irrigation channel, drainage channels and the like.

Scattered Field

In Nalanda district, generally, fields were small and scattered. About 88 % of farms of marginal farmers, 75 % of farms of small farmers, 49 % of farms of medium size farmers and 37 % of farms of large farmers were observed to be scattered over the entire area of village. In some cases, it was beyond the area of the village. Therefore, farmers were unable to use the machinery gainfully. It took much time and labour to transport them from one field to another. Hence, farmers were unable to adopt intensive cultivation.

Lack of Farm Road

Farm roads are the backbone of farm mechanization. It may be appropriate to discuss transportability of other parameters of farming like high yielding seeds, fertilizer, insecticides, pesticides, micronutrients and even farming practices. It may be observed that these parameters can travel to the farm on shoulders of farmers or labourers. All these reached Nalanda district and contributed to increase production. But the major parameter called energy input to farm was found to be still missing. The basic source of energy input to the farm is still a tractor which moves on roads and all of its attachments need farm roads to go to the field. This was one of the most important parameter, which prohibited farm mechanization in Nalanda district. Farmers reported 100 % absence of farm roads. There existed no farm road, no approach road to village. Even a cyclist could not go to his village on a cycle. Some farm-

ers had not heard of farm roads or had no concept of farm roads.

Non-availability of Electricity

Electricity, being a cheaper source of power, is capable of reducing unit cost of operation, which in turn intensifies mechanization. But, due to non-availability of electricity, mechanization was adversely affected. Several farm operations like irrigation, threshing and post production processes could be done at lower cost as compared to diesel power. For intensive cropping patterns, timely irrigation and quick threshing becomes important. It was observed in Nalanda district that the water table was low enough to lower the pumping sets to a depth of 4 to 7 m. Under the circumstances, pumping irrigation water by diesel was uneconomical. This was a bottleneck to farm mechanization.

Poor Economic Condition

About 90 % of marginal farmers, 75 % of small farmers and 20 % of medium size farmers were economically poor. Due to this poor economic condition, in spite of their willingness to own farm implements, they were unable to purchase as these did not come in their order of priority of day to day requirements.

Lack of Genuine Spare Parts and After Sales Service

Farmers faced difficulty in getting genuine spare parts on reasonable price at convenient distance. It badly affected the working of machines. Thus, lack of spare parts for agricultural machinery and equipment was a major problem which greatly affected all mechanization schemes in the district. There was no local service facility.

Credit Availability

The farmers of the district expressed great difficulty in availing credit facilities for the purchase of implements. They reported that

formalities and number of visits required for availing credit were too many. They were also concerned as to how many times they would be required to repay the credit obtained. This was because of suspected foul play in societies. They wanted interest free credit for purchase of implements and machinery.

Conclusions

On the basis of this survey it was found that the number of tractors were about 17 per thousand hectare of cultivated land which was more than double the state average. But use of implements was limited to cultivators and trailers. Similarly, the use of animal drawn and manually operated tools were very few. However, threshers and water lifting pumps were found to be 203 and 376 per thousand hectare area basis.

The main constraint in farm mechanization was lack of extension programmes, farm roads, availability of implements and consolidation of land holdings.

REFERENCES

- Das, S. K. and S. C. Pradhan. 1988. Agricultural mechanization in Orissa, India. *AMA* 19(1): 69-72.
- Kumar, A. and A. Sharma. 1991. Agricultural mechanization in Rajasthan. *AMA* 22(1): 69-72.
- Mittal, V. K., B. S. Bhatia, and A. M. Chauhan. 1989. Food security through farm mechanization. *The Punjab Science. Farm Power and Machinery, ASAE*, Jan. 5-7: 88-95.
- Patel, A. R. 1981. Farm mechanization in India. *Agricultural Engineering Today*. December, 12.
- Ray, A. K. 1993. The present status of Agricultural mechanization and its constraints. *Agricultural Situation in India*. 148(4): 245-250. ■■

Effect of Puddling on Physical Prosperities of Soil and Rice Yield

by

B. K. Behera

Assistant Agricultural Engineer
College of Agricultural Engineering
and Technology, OUAT
Bhubaneswar - 751 003, Orissa
INDIA
biju1964@rediffmail.com

B. P. Varshney

Professor
G. B. Pant University of Agricultural
and Technology,
Pantnagar - 263 145, Uttarakhand
INDIA



S. Swain

Dean
College of Agricultural Engineering
and Technology, OUAT
Bhubaneswar - 751 003, Orissa
INDIA

Abstract

Rice crop requires a good puddled soil condition to create a favourable physico-chemical and microbiological environment for normal growth. The effect of puddling by three puddlers with varying levels of puddling on soil physical properties and yield was studied in a silty clay loam soil of Tarai region. The puddling treatments in the first year of the experiment were rotary puddler with two passes (R_2) and with three passes (R_3), peg type puddler with two passes (P_2) and with three passes (P_3) and cultivator with two passes (C_2) and with three passes (C_3). In the second year experiment, the treatments were peg type puddler with two passes (P_2), peg type puddler with one pass (P_1) and rotary puddler with one pass (R_1). The study revealed that the rotary pud-

dlers gave a better puddling index over other treatments at a particular level of puddling. Increased level of puddling reduced the hydraulic conductivity and increased the bulk density (d. b) of soil. Higher bulk density probably reduced the root growth and yield. Highest yield of 3.63 t/ha was observed in case of P_3 in the first experiment. The yield in case of P_2 , R_2 and C_3 are statistically at par. During the second experiment, there was much higher yield (4.82 to 4.99 t/ha) in all the treatments. There was no significant difference in the yield among the treatments. The study revealed that for silty clay loam soil, reduced level of puddling (one pass) by either rotary puddler or peg type puddler is good enough to get a better yield than higher levels of puddling by either of the above equipments.

Introduction

Rice is a major crop grown in more than 110 countries in the world with a total production of 527 million tonnes, out of which 78 percent is contributed by major rice growing countries of Asia. India is the largest grower of rice in terms of area (42 million ha) in the world with an annual production of 82 million tonnes. However, it ranks second to China in terms of production (187 million tonnes) with an area of 31 million ha (World Rice Statistics, 1994 and Survey of Indian Agriculture, 1999). About 50 percent of the total irrigated area is under rice cultivation in India and hence, 50 percent of irrigation water is used for rice crop whose water requirement is 10^7 L/ha (Manian and Jivaraj, 1989). Since, rice is the lowest productive crop per unit of

water consumption amongst cereals, optimum water management and cultural practices need to be followed to ensure minimum losses of water. Approximately 75 percent of water applied to rice crop is lost through deep percolation during submergence of field (Swaminathan, 1972). Hence, it is cultivated under puddled condition so as to minimize the percolation losses and to enhance the water and nutrient use efficiency of plant. Rice is also grown through direct seeding which is less costly in comparison to transplanting but weed infestation is a severe problem associated with this method. In contrast transplanting using healthy and vigorous seedling gives a more uniform crop stand with higher yield (Khan and Gunkel, 1989). Rice crop requires a good puddled field condition to create favourable physico-chemical and microbiological environment for normal growth of rice plant (Gupta and Jaggi, 1980). However, it has also been reported that excessive puddling is detrimental to subsequent crop in a wetland and dryland crop rotation (Bajpai, 1994). Keeping this in mind, the present study was undertaken in a silty clay loam soil of Tarai region to study the physical properties of soil after puddling by different puddling equipment and their effect on rice yield.

Review of Literature

Puddling and subsequent flooding of rice field increase the growth and productivity of rice (Bhan and Padwal, 1976). Transplanted rice on puddled soil produced more yield than direct seeding rice because of reduction in leaching losses of nitrogen and efficient use of water (Sharma and De Datta, 1985). Lal (1985) reported that for soils with relatively high clay content, there is no obvious advantage in rice yield by puddling over no till method of seed bed preparation. But in medi-

um textured soil, puddling increases grain yield over no till method. (Mambani et al., 1990). Varade and Ghildyal (1967) found that dry matter and grain yield of rice were greater under moderate compaction (1.5 to 1.6 Mg m⁻³) in lateritic sandy clay loam soil, but subsequent increase in bulk density decreased yield. Ghidyal and Satyanarayan (1969) showed that higher bulk density beyond 1.63 Mg m⁻³ not only affected yield adversely but also delayed the plant growth. Sharma and De Datta (1985) observed that puddling significantly increased grains per panicle and plant height and subsequently yield for both clay and clay loam soil by lowering the soil strength at root zone. Sharma et al. (1988), in an experiment of different tillage methods (no tillage, minimum tillage, shallow puddling and deep puddling) on clay and clay loam soil, reported that minimum tillage produced about 26 and 36 percent higher grain yield than that with zero tillage in clay and clay loam soils respectively. The increase of yield in shallow and deep puddling over zero tillage was 33 and 28 percent and 66 and 56 percent for the above soils respectively. They attributed the increase in grain yield due to increase in plant height, panicle length and root length density and decrease in soil penetration resistance.

Sood and Acharya (1991) conducted an experiment on silty clay loam soil with deep ploughing and deep puddling (DP), shallow conventional cultivation and puddling (CP), conventional cultivation and non puddling (CN), compaction after conventional cultivation (CC) and zero tillage without any preparatory tillage (ZT) as the tillage treatments and observed that CC showed significantly higher plant height and number of tillers per hill at all growth stages and higher dry matter accumulation at 30 DAT whereas DP produced higher panicle length and dry matter accumulation at

panicles initiation stage. Treatments CN and ZT were at par but significantly lower than the treatment CP. There was no significant difference of yield between treatment CC and DP. However, yield in case of CP was significantly lower than that of CC and DP and higher than that of CN and ZT.

Sharma et al. (1991) evaluated four bullock drawn puddling equipment (rotary puddler, disc harrow, harrow-cum-puddler and desi plough) with a varying number of passes and reported that rotary blade puddler with two puddlings produced highest yield followed by disc harrow with three puddlings, disc harrow with two puddling and rotary blade puddler with one puddling. Higher yield was attributed to lower percolation losses.

Rath (1999) observed that yield attributing characters and subsequently yield was significantly higher in case of the peg type puddler and compaction after flooding compared to rotary puddler, spade puddling and no tillage in a silty-clay loam soil in the year 1997. But there was no significant difference of yield between peg type and rotary puddler in the year 1998. Low yield in case of rotary blade puddler was attributed to higher hill mortality and greater bulk density of soil leading to lesser root growth. From the above review of literature, it is observed that in a silty clay loam soil, the effect of puddling by different equipment on soil physical properties and rice yield needs to be studied.

Materials and Methods

The study was conducted in University farm of G. B. Pant University of Agriculture and Technology in a silty clay loam soil (Sand: 32.82 %, Silt: 42.00 % and Clay: 25.18 %). After harvest of wheat, one summer ploughing was done by a vertical disc plough and subsequently the

experimental plots were harrowed twice and were leveled by a scraper. In the first year experiment, three puddling equipment, namely, rotary puddler, peg type puddler and cultivator were used with two and three passes. Based upon the results of the first year's experiment, cultivator was dropped as a treatment and puddling was done by rotary puddler and peg type puddler. The details of the puddling treatments are given below:

First year experiment

(Puddling equipment): (Treatment)

Rotary puddler two passes: R₂

Rotary puddler three passes: R₃

Peg type puddler two passes: P₂

Peg type puddler three passes: P₃

Cultivator two passes: C₂

Cultivator three passes: C₃

Second year experiment

Peg type puddler two passes: P₂

Peg type puddler one pass: P₁

Rotary puddler one pass: R₁

The puddling index was measured by standard technique of collecting the puddled soil samples at different places in the experimental plot just after puddling. The bulk density (d.

b) was measured by core sampler method before tillage and 30 and 60 days after puddling (DAP). The hydraulic conductivity of the soil was measured before puddling and 30 and 60 days after puddling by a falling head permeameter as suggested by Rane and Varade (1972). The transplanting was carried out by an eight-row self-propelled rice transplanter. Nitrogen, phosphorous and potassium were applied at the rate of 120, 60 and 40 kg per hectare. Half the dose of nitrogen, and full dose of phosphorous and potassium were applied as basal dose after puddling. Zinc sulphate at 20 kg/ha was also applied after puddling. Remaining half dose of nitrogen was applied in two splits: first at tillering and second at panicle initiation stage. The harvesting was carried out by sickle and threshing was done by a power thresher. The statistical design of the experiment was randomized block design (RBD). The data were analyzed statistically by using analysis of variance (ANOVA) and the means were compared at 5 % level

of significance.

Results and discussion

Effect of Puddling on Physical Properties of Soil

Puddling Index

The puddling index data under different treatments are given in **Table 1**. It is evident from the table that puddling index increased significantly with level of puddling, irrespective of puddling equipment. Increase of puddling index from 36.27 to 43.15, 27.93 to 38.33 and 15.20 to 26.33 percent was observed for rotary puddler, peg type puddler and cultivator, respectively, when level of puddling increased from two to three passes in the first year. It was also clear from the data that puddling index was more for the rotary puddler compared to that of others at each level of puddling. Maximum puddling index of 43.15 percent was recorded for treatment R₃, which was significantly higher than that of other treatments. There

Table 1 Effect of puddling by using different equipment on physical properties of soil

Treatments (Puddling equipment)	Puddling index, %	Bulk density, Mg m ⁻³		Hydraulic conductivity, mm hr ⁻¹	
		30 DAP	60 DAP	30 DAP	60 DAP
First Experiments					
Rotary puddler two passes (R ₂)	36.27	1.542 (8.59*)	1.561 (9.93)	0.234 (71.80)	0.229 (72.41)
Rotary puddler three passes (R ₃)	43.15	1.606 (13.10)	1.636 (15.21)	0.191 (76.99)	0.206 (75.18)
Peg type puddler two passes (P ₂)	27.93	1.499 (5.56)	1.520 (7.04)	0.312 (62.41)	0.303 (63.19)
Peg type puddler three passes (P ₃)	38.33	1.530 (7.75)	1.548 (9.01)	0.239 (71.20)	0.238 (71.33)
Cultivator two passes (C ₂)	15.20	1.446 (1.83)	1.458 (2.68)	0.547 (34.10)	0.551 (33.61)
Cultivator three passes (C ₃)	26.33	1.474 (3.73)	1.498 (5.49)	0.370 (55.42)	0.364 (56.14)
SE m±	0.686	0.013	0.010	0.021	0.014
CD _(0.05)	2.150	0.040	0.032	0.067	0.043

Initial bulk density, Mg m⁻³: 1.42; Initial hydraulic conductivity, mm hr⁻¹: 0.830; Average moisture content of soil, %: 28.30 (30 DAP), 21.50 (60 DAP)

Treatments (Puddling equipment)	Puddling index, %	Bulk density, Mg m ⁻³		Hydraulic conductivity, mm hr ⁻¹	
		30 DAP	60 DAP	30 DAP	60 DAP
Second Experiments					
Peg type puddler one passes (P ₁)	19.40	1.472 (2.22)	1.487 (3.26)	0.315 (51.39)	0.325 (49.85)
Peg type puddler two passes (P ₂)	30.13	1.507 (4.65)	1.519 (5.49)	0.257 (60.34)	0.258 (60.19)
Rotary puddler three passes (R ₁)	24.60	1.492 (3.61)	1.504 (4.44)	0.270 (58.33)	0.263 (59.41)
SE m±	0.513	0.008	0.010	0.010	0.003
CD _(0.05)	2.00	NS	NS	0.040	0.013

Initial bulk density, Mg m⁻³: 1.44; Initial hydraulic conductivity, mm hr⁻¹: 0.648; Average moisture content of soil, %: 28.70 (30 DAP); 23.35 (60 DAP)

* Values in the parenthesis are percentage change

was no significant difference of puddling index between treatments R₂ and P₃ and P₂ and C₃ respectively which showed that peg type puddler and cultivator require three passes each to obtain a similar state of puddling as that of R₂ and P₂. Treatment C₂ had the lowest puddling index of 15.20 percent indicating poor quality of puddling. In the second year experiment, it was observed that puddling index of treatment P₂ (30.13 %) was significantly higher than that of P₁ (19.40 %) and R₁ (24.60 %). Comparing the treatment P₂ between first and second year experiments, it was found that puddling index was higher in second year compared to first year.

Bulk Density (d. b)

Bulk density of puddled soil was determined at 30 and 60 days after puddling (DAP) in both experiments. The details of the results are presented in **Table 1**. In first year experiment, percentage increase of bulk density over unpuddled soil was maximum for treatment R₃ (13.10) followed by R₂ (8.59), P₃ (7.75), P₂ (5.56), C₃ (3.73) and C₂ (1.83), respectively, at 30 DAP. It was observed that bulk density of puddled soil was higher compared to that of unpuddled soil for all the treatments. Increasing the puddling level from two passes to three passes, the bulk density increased significantly in case of rotary puddler and non-significantly for peg type puddler and cultivator. Comparing the treatments individually, it was found that treatment R₃ had maximum bulk density of 1.606 Mg m⁻³ which was significantly higher than that of other treatments, whereas, treatments R₂ (1.542 Mg m⁻³) & P₃ (1.530 Mg m⁻³) and P₂ (1.499 Mg m⁻³) & C₃ (1.474 Mg m⁻³) are statistically at par. Lowest bulk density of 1.446 Mg m⁻³ was obtained in case of treatment C₂. At 60 DAP, an increase in bulk density over 30 DAP was observed for all treatments and it followed a trend similar to that of 30 DAP except for C₂ and C₃. At

30 DAP, bulk density for C₂ (1.446 Mg m⁻³) and C₃ (1.474 Mg m⁻³) was statistically at par but it differed significantly at 60 DAP with values of 1.458 and 1.498 Mg m⁻³. During the second experiment, highest bulk density was recorded for treatment P₂ followed by treatments R₁ and P₁ both at 30 and 60 DAP. However, there was no significant difference of bulk density among treatments both at 30 and 60 DAP (**Table 1**).

Hydraulic Conductivity

Hydraulic conductivity was measured by falling head permeameter under field condition at 30 and 60 DAP. Data on hydraulic conductivity are given in **Table 1**. Perusal of data revealed that irrespective of puddling equipment used, hydraulic conductivity of soil decreased after puddling and the decrease was more pronounced for treatment R₃ (76.99 %) at 30 DAP in the first year. Increasing the puddling level from two to three passes decreased the hydraulic conductivity from 0.234 to 0.191, 0.312 to 0.239 and 0.547 to 0.370 mm hr⁻¹ for rotary puddler, peg type puddler and cultivator respectively. The decrease of hydraulic conductivity with increase of

level of puddling was found significant in case of peg type puddler and cultivator and non-significant for rotary puddler. Maximum hydraulic conductivity of 0.547 mm hr⁻¹ was observed in case of treatment C₂ which was significantly higher than that of all other treatments. It was further noticed that hydraulic conductivity for treatments R₂, R₃ and P₃ are statistically at par, but they differed significantly from treatments P₂ and C₃, which were statistically at par. At 60 DAP, hydraulic conductivity was almost equal to that of 30 DAP indicating stabilization of hydraulic conductivity. Similar observations were reported by Awadhwal and Singh (1985).

In the second experiment, minimum hydraulic conductivity of 0.257 mm hr⁻¹ was found in case of P₂ which was significantly lower than that of P₁ (0.315 mm hr⁻¹) but statistically at par with R₁ (0.270 mm hr⁻¹). At 60 DAP, there was no appreciable variation in hydraulic conductivity over that of 30 DAP.

The data on the yield attributes and the yield under different treatments are given in **Table 2**. It was observed that treatment P₃ had the

Table 2 Effect of puddling on yield attributes and yield of rice under different treatments

Treatments (Puddling equipment)	Root dry weight, g	No. panicles /m ²	No. grains/ panicle	Unfilled grain, %	Yield, t/ha
First Year Experiments					
Rotary puddler two passes (R ₂)	3.56	262.62	87.20	30.22	3.40
Rotary puddler three passes (R ₃)	3.13	262.57	83.40	28.49	3.20
Peg type puddler two passes (P ₂)	3.45	284.36	86.88	29.70	3.37
Peg type puddler three passes (P ₃)	3.66	293.64	90.22	29.30	3.63
Cultivator two passes (C ₂)	2.95	256.95	77.17	32.49	2.93
Cultivator three passes (C ₃)	2.92	261.33	81.48	30.45	3.25
Mean	3.28	271.42	84.39	30.11	3.30
SE m±	0.079	7.234	1.169	0.724	0.050
CD _(0.05)	0.250	22.79	3.682	2.280	0.158
Second Year Experiments					
Peg type puddler two passes (P ₂)	4.60	353.24	106.86	15.78	4.82
Peg type puddler one passes (P ₁)	4.17	365.17	115.57	14.52	4.99
Rotary puddler one passes (R ₁)	4.27	363.93	112.43	15.34	4.93
Mean	4.35	360.78	111.62	15.21	4.91
SE m±	0.081	7.204	10.86	0.324	0.173
CD _(0.05)	0.278	NS	4.24	NS	NS

highest yield of 3.63 t/ha followed by R₂ (3.40 t/ha), P₂ (3.37 t/ha), C₃ (3.25 t/ha), R₃ (3.20 t/ha) and C₂ (2.931 t/ha). Treatment P₃ was statistically superior to all other treatments whereas treatment P₂, R₂ and C₃ are statistically at par. During second year experiment, maximum grain yield of 4.99 t/ha was obtained in case of P₂ followed by R₁ (4.93 t/ha) and P₁ (4.82 t/ha). It was observed that even with low level of puddling the grain yield was remarkably higher than that obtained in the first experiment.

Discussions

During puddling, soil undergoes two types of deformations: first, due to normal stress which is associated with compression and second, because of tangential stress causing shear. Compression is most effective below upper plastic limit whereas shear effect dominates above it. Since, puddling is done under saturated condition of soil, it is shear stress, which causes dispersion of soil particles in water. Rotary puddler due to rotary motion of its blades matches the weakest fracture plane of soil mass disintegrating it into fine particles (Sharma and De Datta, 1985). This is the reason for higher puddling index in case of rotary puddler. Besides that, the angular orientation of blade (30°) in rotary puddler creates a cycloid action of the blade on the soil thereby increases the churning of soil and water mixture, which enhances the puddling index (Tewari, 1984). Low puddling index in case of peg type puddler and cultivator may be due to combing action of the soil working elements of the puddling equipment. Higher puddling index in case of peg type puddler compared to cultivator at a same puddling level may be because of close spacing of pegs. Puddling index for P₂ in the second year was higher compared to that of 1998. It may be because of weed

free and well-prepared initial field condition.

After dispersion of soil particles by puddling, flocculation takes place and there is a stratified settlement of soil particles leading to destruction of macro pores, which creates a dense soil. Higher the dispersion of soil particles in water (puddling index), higher is the bulk density. It has also been noticed that, though there is significant increase of puddling index with level of puddling (2 to 3), the bulk density increased significantly only in case of rotary puddler. This might be due to higher puddling index in case of rotary puddler and lower in case of peg type puddler and cultivator, which may not be contributing towards the destruction of macro pores as in case of rotary puddler. Bulk density increased with respect to time. This might be due to shrinkage of soil at lower moisture content. Average moisture content of soil at 30 DAP was 28.30 and 28.70 percent in First and second year of experiment respectively whereas it was 21.50 and 23.35 percent at 60 DAP for the above years. The findings corroborate with the results reported by Scheltema (1974); Bajpai (1994) and Rath (1999).

The hydraulic conductivity depends upon the amount and size of coarse pores (transmission pores) in the soil. Considerable reduction of hydraulic conductivity of puddled soil over unpuddled was observed in case of all treatments under the study. This might be due to clogging of pore space channels on settling of soil particles after puddling. Clogging of these channels reduce the water transmission pores which results in decreasing hydraulic conductivity. Similar results were reported by Bhole and Pandya (1962); Naphade and Ghildyal (1971); Rane and Varade (1972); Tyagi et al. (1974); Sharma and DeDatta (1985) and Sharma et al. (1991). At higher level of puddling, viscosity of puddled soil increases. Hence, water

moves at a very slow rate, which in turn enhances lodgment of finer particles. Lodgment favours a more closely packed soil medium, which reduces hydraulic conductivity considerably (Alva and Petersen, 1979). This might be the reason for lower hydraulic conductivity in case of treatment R₃ where there was maximum dispersion of soil particles in water.

Grain yield is affected by physico-chemical status of soil and optimum plant population taking into account others parameters constant for all treatments. Poor performance of treatment C₂ may be due to less nutrient availability because of higher leaching losses resulting due to greater hydraulic conductivity. Similar observations were made by Tyagi et al. (1975); Sharma and De Datta (1986); Sharma et al. (1988) and Rath (1999). Although the puddling quality was good in case of R₃, its performance in term of yield was found poor. This may be due to low plant population resulting from higher mortality because of more buried and floating hills after transplanting by the self-propelled transplanter. Another reason for poor yield may be higher bulk density leading to poor root growth (**Table 2**). Reduction in yield as a result of higher bulk density was also reported by Ghildyal and Satyanarayan (1969); Gupta and Jaggi (1979). The soil physical properties obtained after puddling were almost similar for treatments P₃ and R₂ but P₃ contributed more grain yield than R₂ which might be due to more of panicles per sq.^m (P₃: 323.97, R₂: 287.45) (**Table 2**). In comparison to C₂ grain yield, C₃ was significantly higher. This may be due to less leaching losses because of comparatively lower hydraulic conductivity (**Table 1**). Low grain yield in the first experiment compared to the second might be due to late transplanting, stem borer infestation and higher percentage of unfilled grains. The hill population was higher in the second experi-

ment because of less mortality and hill spacing. In the second experiment the hill spacing was set at 10 cm whereas it was 12 cm during the first experiment. The transplanting during the first experiment was carried out in the last week of July whereas it was performed in the first week of the same month in the second experiment. Although the met at 20 kg per hectare was applied to control the stem borer, they migrated from the nearby field. There was a heavy rainfall of 283.5 mm in the third week of October which was before harvesting which might have facilitated the attack of gandhibug resulting in an increase of unfilled grain of 28-34 percent in the first experiment while it was only 12-16 percent in the second experiment.

The yield was found higher, even if the puddling level was reduced in the second experiment. Well prepared and weed free initial field condition might have improved the quality of puddling in terms of bulk density and hydraulic conductivity (**Table 1**) giving a better root and crop growth and ultimately higher yield.

Conclusion

The results of the study indicate that cultivator is not ideal equipment for puddling. Treatment R₃ reduced the bulk density and hydraulic conductivity of the soil considerably in comparison to other treatments but the root growth and subsequently the yield was less. Treatment P₃ produced higher rice yield in the first year experiment whereas, in the second year experiment with reduced puddling level, the yield was much higher. This indicates that for silty clay loam soil reduced puddling gives more yield. There was no significant difference in the soil physical properties with reduced puddling level among the treatments in the second year experiment. Hence, to reduce the cost of tillage

and time, treatment R₁ and P₁ should be preferred to other treatments.

REFERENCES

- Anonymous. 1994. World Rice statistics. IRRI, Manila-1099, Philippines.
- Anonymous. 1999. Survey of Indian agriculture.
- Alva, A. K. and L. Paterson. 1979. Soil physical properties in relation to rice yields and water consumption under flooded and unflooded condition. *Plant Soil*. 52: 353-363.
- Awadhwal, N. K. and C. P. Singh. 1985. Characterization of puddled soil. *J. Agric. Engg. ISAE*. 22(1): 9-14.
- Bajpai, R. K. 1994. Effect of tillage methods and fertility levels on soil physical properties, crop growth and productivity in rice-wheat cropping system. Thesis, Ph. D. GBPUAT, Pantnagar.
- Bhan, S. and V. D. Padwal. 1976. Effect of soil and water management practices on yield and water use of direct seeded rice under light textured alluvium soil of Uttar Pradesh. *Indian J. Agric. Sci*. 46: 503-506.
- Bhole, N. G. and A. C. Pandya. 1964. Puddling of soil. The harvester. (*J. Agri. Engg. Soc.*), IIT, Kharagpur. 7: 11-17.
- Ghildyal, B. P. and T. Satyanarayana. 1969. Effect of compaction on physical properties and management of paddy soils. Pp. 42-58. In: *Proceedings Symposium. Paddy soil*. Nanjing, China. 19-24 Oct. 1980. Science Press. Beijing, China.
- Gupta, R. K. and I. K. Jaggi. 1979. Soil physical conditions and paddy yield as influenced by depth of puddling. *J. Agron. Crop Sci*. 148: 329-336.
- Khan, A. S. and W. W. Gunkel. 1988. Mechanical transplanting of rice in Pakistan. *AMA*. 19(1): 21-34.
- Lal, R. 1985. Tillage in low land rice based cropping systems. In: *Soil Physics and Rice*, IRRI, Philippines. Pp. 283-307.
- Manian, R. and P. Jivaraj. 1989. Puddled characteristics of soil with selected implements. *AMA*. 20 (1): 21-24 & 26.
- Mambani, B., S. K. De Datta, and A. C. Redula. 1989. Soil physical behaviour and crop response to tillage in lowland rice soil of varying clay content. *Plant Soil*. 126 (2): 227-235.
- Naphade, J. D. and B. P. Ghildyal. 1971. effect of puddling on physical properties of rice soil. *Indian J. Agric. Sci*. 41 (12): 1065-1067.
- Rane, D. B. and S. B. Varade. 1972. Hydraulic conductivity as an index for evaluating the performance of different puddlers. *J. Agric. Engg*. 9 (1): 11-16.
- Rath, B. S. 1999. Studies of wheat sowing at various levels of puddling in rice under rice-wheat cropping system. Thesis, Ph.D. GBPUAT, Pantnagar.
- Scheltema, W. 1974. Puddling against dry ploughing for low land rice culture in Surinam *Agril. Res. Rep.* 823. Centre for Agril. Publishing and Documentation, Wageningen, Netherlands. 241P
- Sharma, P. K. and S. K. De Datta. 1985. Puddling influence on soil, rice development and yield. *Soil Sci. Soc. Am. J.* 49: 1451-1457.
- Sharma, P. K. and S. K. De Datta. 1985. Physical properties and processes of puddled rice soils. *Adv. Soil sci*. 5: 139-178.
- Sharma, P. K., S. K. De Datta, and A. C. Redula. 1988. Tillage effects on soil physical properties and wetland rice yield. *Agron. J.* 80 (1): 34-39.
- Sood, M. C. and C. L. Acharya. 1991. Effect of tillage on root plant growth and nutrient uptake by wetland rice on acidic alfisol. *Ann. Agric. Res.* 12 (4): 344-351.
- Swaminathan, M. S. 1972. Scientific management and user of water. *Indian farming*. 22 (2): 5-7.



Ground Contact Pressure and Soil Sedimentation Period Affecting Transplanter Sinkage and its Performance

by

B. K. Behera

Assistant Agricultural Engineer
College of Agricultural Engineering
and Technology, OUAT
Bhubaneswar - 751 003, Orissa
INDIA
bju1964@rediffmail.com

B. P. Varshney

Professor
G. B. Pant University of Agricultural
and Technology,
Pantnagar - 263 145, Uttaranchal
INDIA



S. Swain

Dean
College of Agricultural Engineering
and Technology, OUAT
Bhubaneswar - 751 003, Orissa
INDIA

Abstract

Self-propelled transplanter has problems of poor traction and sinkage and requires ideal soil condition for proper working. Too soft soil increases the sinkage of the float of the transplanter and leads to a higher percentage of buried and floating hills and subsequently increases the hill mortality. A study was conducted to determine the sinkage of the transplanter through a sinkage device under simulated conditions and later on verified on the field by the transplanter itself. Good agreement between the simulated sinkage and actual sinkage was observed. Further study on the performance of the transplanter showed that ideal transplanting time should be 48 hours after puddling for a silty clay

loam soil. Sinkage of the float had good correlation with buried and floating hill as well as with the hill mortality.

Introduction

Manual transplanting, still prevalent in most parts of the country, is labour intensive and requires 250-350 man-hours per hectare, which is 25 percent of the total labour requirement of the crop (G. Singh and U. K. Hussain, 1983). In addition to being labour intensive, manual transplanting involves a lot of human drudgery, reducing the efficiency appreciably. Manual transplanter, the first substitute of manual transplanting, requires 70-80 man-hours per hectare, reduces the la-

bour requirement by 55 percent (G. Singh and U. K. Hussain, 1983). But it has been observed that the use of manual transplanter is still associated with human drudgery and low work capacity ranging from 0.01 to 0.015 ha h⁻¹. Therefore, gradually, the attention has been shifted to self-propelled rice transplanter whose work capacity varies from 0.12 to 0.15 ha per hour (B. K. Behera, 2000).

Like all other wetland agricultural machinery, a self-propelled rice transplanter has problems of poor traction, sinkage and steerability. Since a self-propelled rice transplanter works on puddled soil, it encounters a hard surface at the plow pan and a soft puddled soil at the top where it must have sufficient bearing capacity to prevent sinkage

of the float. At the same time, the plow pan must not be too deep to provide necessary traction to propel the transplanter. Both traction and bearing capacity are dependent upon shear strength of the soil (Knight and Freitag, 1962). Usually a transplanter would be immobilized by failure in either bearing of the machine on the soil or traction. Efficient working of a self-propelled rice transplanter requires suitable puddled soil conditions *vis-à-vis* optimum depth of puddling, degree of puddling and strength of puddled soil. High degree of puddling severely affects the mobility of the transplanter and its performance due to sinkage and poor traction and requires a longer sedimentation period.

Sinkage of the transplanter depends on the ground contact pressure and the softness of top layer of the puddled soil, which is directly affected by degree of puddling, type of puddling equipment and sedimentation period. Sinkage with respect to contact pressure and sedimentation period will be of immense help in designing the machine. Keeping this in mind, the present study was undertaken to simulate the sinkage of a transplanter with respect to different contact pressures through a sinkage device. The transplanter was also operated in the field to assess the sinkage of the float and its performance.

Materials and Methods

The study was conducted in a silty clay loam soil (sand: 32.82 %; silt: 42 %; clay: 25.18 %) at G. B. Pant University of Agriculture and Technology, Pantnagar, Uttaranchal in the year 1999. Puddling of the field was carried out by two puddling units namely: peg type puddler and rotary puddler. One pass of peg type puddler (P₁), two passes of peg type puddler (P₂) and one pass of rotary puddler (R₁) were the three

main treatments of the experiment. Three sedimentation periods of 24, 36 and 48 hours were considered as the sub-treatment. The transplanter was self-propelled as shown in Fig. 1. In operating condition, the transplanter rests on the traction wheel at the front and on the float at the back.

The sinkage of the transplanter was simulated by a sinkage device (Fig. 2). The sinkage device had a base plate fixed to the center that was a rectangular bar 25 x 25 mm. Over the rectangular bar, a m. s. plate was welded onto which weights could be placed to get the desired contact pressure at the base plate.

The dimension of the base plate was determined by dimensional

analysis as described below:

The general prediction equation of sinkage will be:

$$X = f(W, L, B, C) \dots\dots\dots(1)$$

Where,

X = Sinkage,

W = Weight on the float

L = Length of the float

B = Breadth of the float

C = Resistance of the puddled soil

The effect of standing water on sinkage was not considered because, under both actual and simulated condition, the same water level was maintained.

By dimensional analysis, the dimensionless π terms are:

$$\pi_1 = X / B; \pi_2 = L / B; \pi_3 = W / (C \times L \times B)$$

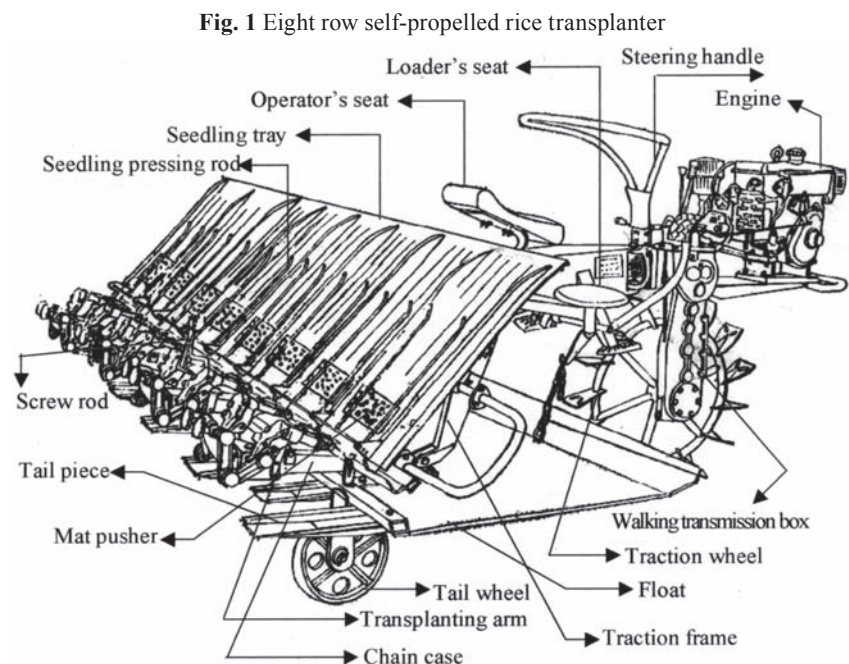

Fig. 1 Eight row self-propelled rice transplanter

Sl. no	Items	Specifications
1	Model	2ZT-238-8
2	External dimensions; L x W x H, mm	2410 x 2131 x 1300
3	Weight, kg	Air cooled 2.4 kW diesel engine
4	Engine	320
5	Number of rows	8
6	Row spacing, mm	238
7	Hill to hill spacing, mm	(i) 100, (ii) 120
8	Frequency of transplanting	263
9	Depth of transplanting	Infinitesimal adjustment with screw rod
10	Operating speed, km/h	(i) 1.57, (ii) 1.94
11	Width of transplanting finger, mm	12.5
12	Width of seedling gate, mm	16

Where,

$L \times B =$ Area of the float

Applying the theory of model, the design conditions for the model of the float (base plate of the sinkage device) is as follows:

$$X / B = X_m / B_m \dots\dots\dots(2)$$

$$L / B = L_m / B_m \dots\dots\dots(3)$$

$$W / (C \times B \times L) = W_m / (C_m \times B_m \times L_m) \dots\dots\dots(4)$$

Where, 'm' represents the model

The length scale of the model will be $L_m / B_m = L / B = 182 \text{ cm} / 77 \text{ cm} = 2.36$

Assuming the breadth of the model to be 12 cm, the length of the model will be:

$$12 \times 2.36 = 28.32 \text{ cm.}$$

The thickness of the base plate was 5 cm. The detail of the sinkage device has been given in Fig. 2.

Simulation of Load on the Float

The load on the model (sinkage device) to simulate contact pressure was done by using the design condition of the model as derived from equation (4):

$$W_m = W \times (C_m \times B_m \times L_m / C \times B \times L) \dots\dots\dots(5)$$

Since, $C_m = C$, as the soil condition was same for both the transplanter and the sinkage device, the above equation will be:

$$W_m = W \times (B_m \times L_m / B \times L) \dots\dots(6)$$

$$W_m = W \times (12 \times 28.32 / 77 \times 182 = W \times 0.024 \dots\dots\dots(7)$$

The load on the float was determined by weighing the machine in a weighbridge.

Weight of the transplanter without operator and seedling mat = 320 kg.

Load on the float = 150 kg.

Load on the traction wheel = 170 kg.

The load distribution on the float when additional loads are added was found to be:

a. With operator seated and seedling mat on the transplanter tray = 206 kg.

b. With additional two loaders along with operator and seedling mat on the tray = 266 kg.

c. With 8 additional seedling mats on the float along with operator, two loaders and seedling mat on the tray = 298 kg.

Putting the above loads in equation (6), the simulated loads on the sinkage device will be 4.94, 6.38 and 7.152 kg, respectively. However, the experiment was conducted with loads of 3, 4, 5, 6 and 7 kg, which includes the weight of the sinkage device. The corresponding contact pressures on the device were 8.83, 11.77, 14.71, 17.66 and 20.60 g cm^{-2} . The contact pressure of the sinkage device with the puddled soil was determined by dividing the load by the area of the base plate of the device. The contact pressure of the float of the transplanter with the puddled

soil was determined by dividing the load on the float by the area of the float.

Measurement of Sinkage

The sinkage device was placed on the undisturbed marked area of the puddled soil for each treatment and weights were put on it to simulate required contact pressure. The sinkage of the base plate into the puddled soil was noted from four scales attached at four sides of the central rectangular bar to measure the sinkage and the average was taken as the representative sinkage. Five observations were taken for each treatment. Constant water level of one cm was maintained throughout the experiment to simulate the ideal transplanting condition. Observations on sinkage were taken at 24, 36 and 48 hours of sedimentation periods.

Actual sinkage of the float of the transplanter during transplanting was determined by subtracting the pre-set depth (3 cm) of transplanting from the actual depth of transplanting. The transplanter had a provision for setting the depth of transplanting and it was presumed that actual depth of transplanting was the sinkage of the float plus the pre-set depth of transplanting. The buried and floating hills along with hill mortality were determined as suggested by (Singh et al., 1985).

Fig. 2 Sinkage device for measurement of sinkage

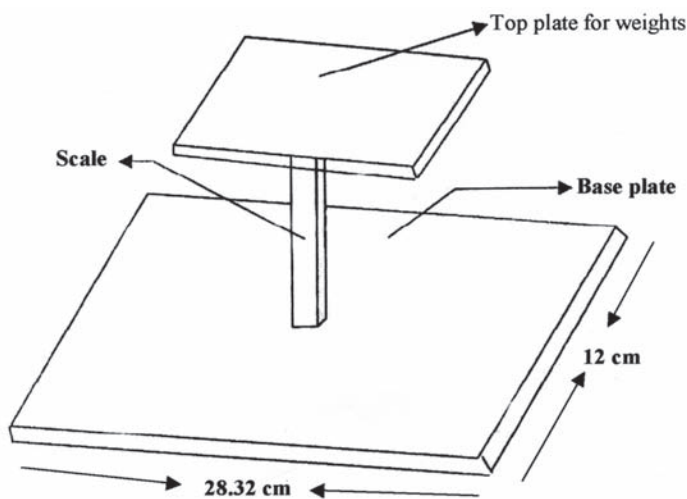

Results and Discussions

The sinkage of the device under different soil conditions as obtained by the puddling equipment, degree of puddling and the sedimentation period has been presented in Table 1.

It was observed that the sinkage of the device simulating the sinkage of the transplanter increased with increase of contact pressure for each puddling equipment and degree of puddling. A decrease of sinkage was also noticed when the sedimen-

tation period increased irrespective of puddling equipment and degree of puddling. Maximum sinkage of 3.85 cm was found in the case of the peg type puddler with two passes followed by rotary puddler with one pass (3.33 cm) and peg type puddler with one pass (3.11 cm) after 24 hours of sedimentation period at a contact pressure of 20.60 g cm⁻² that represents an operating condition of the self-propelled rice transplanter with operator, two loaders and seedling mat both on the tray and on the float. When the sedimentation period increased from 24 to 36 hours, the sinkage reduced to 1.40, 2.20 and 2.15 cm for the peg type puddler with one pass (P₁), peg type puddler with two passes (P₂) and rotary puddler with one pass (R₁), respectively. The corresponding sinkages were 0.85, 1.61 and 1.38 cm after 48 hours of sedimentation period (Table 1). However, it was observed that there was appreciable decrease in sinkage between 24 to 36 hours of sedimentation period than as compared to 36 to 48 hours. A similar trend was observed for other contact pressures under different sedimentation periods. Maximum sinkage in case of peg type puddler with two passes may be due to softer soil because of good puddling (Puddling index: 30.13 %).

The transplanter was operated under a contact pressure of 14.71 g cm⁻² in the puddled field as created by different puddling equipment after 24, 36 and 48 hours of sedimentation periods. It was observed that the peg type puddler with two passes caused maximum sinkage of 2.69 cm at 24 hours of sedimentation period followed by rotary puddler with one pass (2.58 cm) and peg type puddler with one pass (2.38 cm). Quite similar to the trend observed in case of the sinkage device, the sinkage of the float of the transplanter decreased with increase in sedimentation period. It was noticed that the observed sinkage was slightly less compared

to the simulated sinkage at 14.71 g cm⁻² contact pressure. However, the test of goodness of fit ($\chi^2 = 0.053$) showed that the observed sinkage of the transplanter and simulated sinkage were at par at 1 percent level of significance.

The buried and floating hill percentage demonstrated a decrease as the sedimentation period increased as did the hill mortality (Table 2). A good correlation ($R_2 = 0.839^*$) between sinkage and buried and floating hill was observed (Fig. 3). Sinkage depends on the softness of the soil. With soft soil leading to more sinkage, there is a flow of soil along with the float resulting in more percentage of buried and floating hills which ultimately increased the hill mortality. There also exists a good correlation ($R_2 = 0.796^*$) between sinkage and hill mortality (Fig. 4).

From the study, it was observed that buried and floating hill percent-

age was appreciably high after 24 hours of puddling which showed that transplanting should not be done after 24 hours of puddling for a silty clay loam soil. For the peg type puddler with two passes, the ideal condition is after 48 hours of puddling. For the other treatments, transplanting could be done after 26 hours of sedimentation period as observed from the field experiment. It has been reported that sinkage above 2 cm in a soil is considered to represent too soft a soil for transplanting and sinkage less than 1 cm is too hard for transplanting (Garg, 1999). Taking that as a reference, it can be said that for a contact pressure of 20.66 g cm⁻² which was obtained by the load condition at which the transplanter should be operated to increase the efficiency by reducing the seedling mat feeding time, the ideal transplanting time should be 48 hours after the

Table 1 Effect of contact pressure on sinkage of the sinkage device under different puddled soil conditions

Puddling equipment	Sedimentation period	Sinkage, cm				
		Contact pressure, g cm ⁻²				
		8.83	11.77	14.71	17.66	20.66
P ₁	24	1.85	2.01	2.50	2.92	3.11
	36	1.01	1.21	1.40	1.22	1.40
	48	0.29	0.35	0.50	0.73	0.85
P ₂	24	2.09	2.40	2.90	3.12	3.85
	36	1.20	1.35	1.70	1.95	2.20
	48	0.80	0.95	1.32	1.46	1.61
R ₁	24	1.90	2.40	2.85	2.95	3.33
	36	1.00	1.31	1.62	1.75	2.15
	48	0.42	0.80	1.21	1.06	1.38

Table 2 Observed sinkage, buried and floating hill and hill mortality under different puddled soil condition

Puddling equipment	Sedimentation period	Observed sinkage at 14.71 g cm ⁻² contact pressure	Buried hill, %	Floating hill, %	Hill mortality, %
P ₁	24	2.38	3.33	2.93	4.88
	36	1.20	1.97	0.75	1.97
	48	0.92	0.53	0.00	0.00
P ₂	24	2.69	5.78	4.05	8.28
	36	1.56	2.50	1.55	4.23
	48	1.19	1.32	1.30	2.59
R ₁	24	2.58	3.27	3.30	5.37
	36	1.33	1.55	0.78	1.77
	48	1.10	0.00	0.00	2.78

puddling for all treatments under the study. However, this study was limited to silty clay loam soil and further investigation could be made with different soils and level of puddling with other puddlers.

a self-propelled rice transplanter should be 48 hours after puddling for peg type puddler with two passes.

Conclusions

Peg type puddler with two passes caused maximum float sinkage of 2.69 cm at 24 hours of sedimentation period followed by rotary puddler with one pass (2.58 cm) and peg type puddler with one pass (2.38 cm). It was noticed that the observed sinkage was slightly less compared to the simulated sinkage at 14.71 g cm⁻² contact pressure. However, the test of goodness of fit ($\chi^2 = 0.053$) showed that the observed sinkage of the transplanter and simulated sinkage were at par at 1 percent level of significance. The simulated sinkage obtained by the sinkage device could be used as representative of the sinkage of the float and can be used to determine the ideal transplanting time after puddling. With increase in sedimentation period the sinkage, buried and floating hill and the hill mortality decrease and there was a good correlation between sinkage and buried and floating hill ($R_2 = 0.839^*$). For silty clay loam soil, the ideal transplanting time by

REFERENCES

- Behera, B. K. 2000. "Investigation on puddled soil characteristics in relation to performance of self-propelled rice transplanter". Unpublished Ph. D Thesis. G. B. P. U. A & T, Pantnagar.
- Garg, I. K. 1999. Effect of ground contact pressure and soil settlement period on paddy transplanter sinkage. Personal communication, PAU, Ludhiana.
- Knight, S. J. and D. R. Freitag. 1962. Measurement of soil trafficability characteristics. Trans. ASAE. vol. 5: 121-124.
- Singh, G. and U. K. Hussain. 1983. Modification and testing of a manual rice transplanter'. Agricultural Mechanization in Asia, Africa and Latin America, vol. 14 (2): 25-30.
- Singh, G., T. R. Sharma, and C. W. Bockhop. 1985. Field performance evaluation of a manual rice transplanter. J. Agric. Engg. Res. 32: 259-268.



Fig. 3 Relationship between sinkage and buried & floating hill

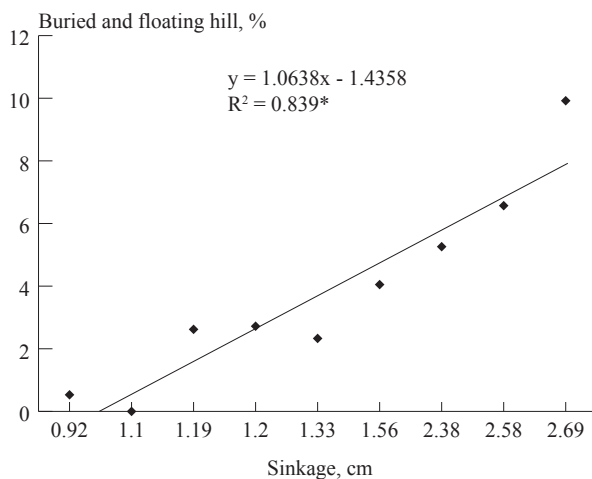
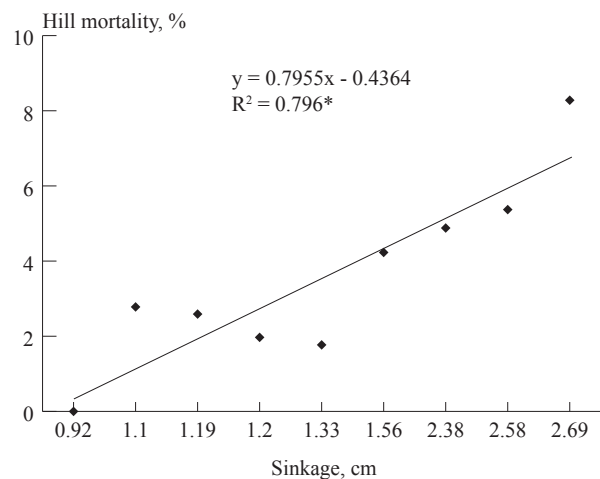

Fig. 4 Relationship between sinkage and hill mortality



Development of a Reinforced Mud Silo

by

A. F. Alonge

Lecturer
Department of Agricultural Engineering,
University of Ilorin,
Ilorin
NIGERIA
falonge6@yahoo.com

A. A. Opeloyeru

Graduate Student
Department of Civil Engineering,
Rivers State University of Technology,
Port Harcourt
NIGERIA

Abstract

An experimental mud silo was designed, constructed with mud. The mud from Oyun River (along University Road, Ilorin, Nigeria) was subjected to tests using the Cob, Wattle and Daub method before construction was carried out on the two soil types from two different locations. The soil samples from the river has a plastic index of 38.50 % and bulk density of 1.65 g/cm³, while the sample collected from Okelele in Ilorin had a plastic index of 22.2 % and bulk density of 2.85 g/cm³. The silo was constructed with local available materials such as clay, wood and plywood. Tests showed that the relative humidity and moisture content of four-grain types stored increased until a temperature of 29 °C was reached. It then decreased until the hygroscopic equilibrium was reached at a temperature of 21 °C. The outside temperatures, due to low thermal conductivity of the mud used, influenced the temperature in the silo at a very low or negligible rate. There was no development of mould or

insect activity observed. For storage of bean, yellow maize, white maize and sorghum in mud silos, a relative humidity of below 75 % and a temperature of 29 °C or less is recommended.

Introduction

Storage of grains dates back to Bible days with the building of pyramid stores in Egypt by the Israelites, in the cities of Pithom and Ramses (The Holy Bible, Exodus 1:11, 5:16). They made bricks from straw and well-mixed mud; fired the mud and used it in building. The building of these storage structures, though tedious, served as a timely saving gesture against starvation for Egypt and its environs.

Ditcher (1981) in Ghana noted that ordinary mud is moulded into mud bricks and they are used for circular walls from a locally made mould. Ghana German Agricultural Development Project (GGADP) has adopted the improved form of this type of silo. Igbeka (1983) pointed out that Nigeria exists in

three climatic zones; the lowland humid zone of the south, the Guinea Savannah of the middle belt and the Arid and Semi-Arid region of the North. It is observed that storage structures made from mud, ranging from mud Rhumbus in the North to mud silo and earthenware roots in the south and middle belts are common and universally accepted.

Thatched rhumbus are commonly found in the Northern States of Nigeria especially Adamawa and Borno states. Grains are usually stored in shelled or unshelled form. The structure, which is made from thatches and palm fronds, is supported on wooden structures or stones. The walls are provided with tension rings in about three places. These tension rings are made from local rope materials. This kind of structure has been disqualified because of fire hazards, and it is not moisture proof.

Mud Rhumbus or bins range from small to large size. It is a very common for storage and modifications are made in the shape and size in accordance to the environment in which it is to be used. It is found

mainly in cylindrical shape. The cover is conical and can be made up of either mud or thatches. The opening is sealed after it is filled with grains. It usually has four compartments for storing different grains and a provision made for a chicken to live underneath it. This is to control infestation by pest.

Many of the traditional structures mentioned have limitations particular in durability, protection against moisture and ambient air. Losses are incurred from plant pest causing deterioration, discoloration and loss of nutrients, mould development on crops due to inadequate drying, pilfering by people, and shattering of grains due to premature harvest. Hence, the need for a modified mud silo arises for this chosen design. This work is a prototype that falls between the mud Rhumbus (used in the North) and the mud silo in the South. The ability of mud being able to maintain relatively constant temperature in structures and its effects on the storability of grains was exploited.

This paper presents the design, construction and testing of a mud silo with materials that are cheap, readily and locally available. Additional desirable characteristics that

it should have are stable and capable of bearing design loads, portable and can easily be maintained, reasonably insect-proof, and have ease of loading and unloading and with reduced temperature fluctuation in the bin.

Materials and Method

Design Considerations

The following points were taken into considerations for the mud silo:

- i. A stable structure, capable of bearing the desired load.
- ii. Cheap and easily maintained structures
- iii. Ease of cleaning
- iv. Fire proof structure
- v. Ease of loading and unloading
- vi. Reasonably insect proof, thus reducing insect infestation.
- vii. Prevention of violent temperature fluctuations thus improving storage quality.
- viii. Permit effective pest control practices such as fumigation.

The considerations made before designing can be explained as those factors that dictates the materials and design chosen for construction.

Material Selection

The selection of materials for constructions are based on their availability, cost durability and ease of maintenance. Some phase related properties or qualities were tested

before choosing materials for construction. The following tests were carried out on clay obtained from the two best clayey area of the town.

1. Sieve analysis
2. Determination of specific gravity, bulk density and dry density
3. Testing for Atterberg limits.
4. Determination of moisture content (wet basis)

Lambe and Whitman (1976) and Bengtsson and Whitaker (1987) gave the detailed procedure for carrying out these tests. For this work two soil samples were tested. The first one was from Oyun River along the University Road while the second sample was from Okelele, Ilorin, Kwara State. The result of the various test carried out showed that both clay samples fell under the illite group. Plasticity Index (PI), which is the arithmetic difference between the liquid limit and plastic limit, ranged from 33 % to 67 %. The plasticity index of sample 1 from Oyun River was 38.5 %, and sample 2 from Okelele was 22.2 %. The soil from Oyun River was used in construction because it was more plastic. The first soil sample was more unfairly distributed and graded than that of the second sample.

Design Analysis

The major calculations and analysis carried out on the design of the mud silo were:

1. Pressure Analysis on the Silo.

Fig. 1 Pictorial view of the reinforced mud silo

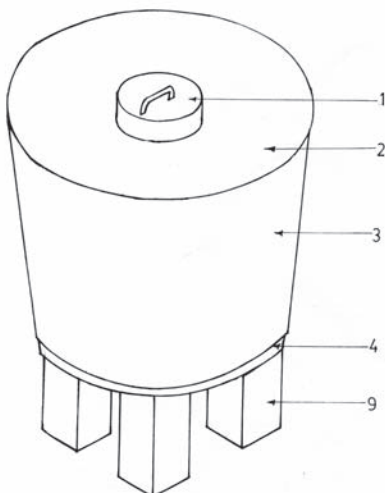

1: Inlet cover, 2: Roof, 3: Reinforced mud wall, 4: Base, 5: Partition, 6: Slot, 7: Wall reinforcement, 8: Outlet cover, 9: Stand, 10: Roof support

Fig. 2 Sectional view of the reinforced mud silo

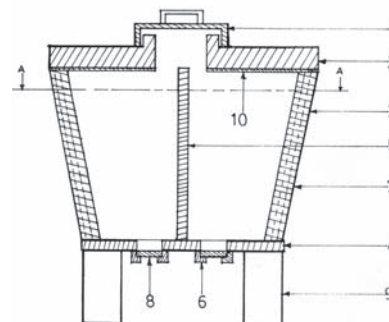
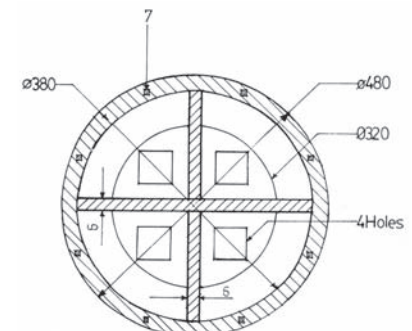

Fig. 3 Plan view of the reinforced mud silo (Section A-A)



This is described in Mijinyawa (1993)

In this work, the silo was shallow since the lateral dimension chosen was less than the height of the silo. In analysis of pressure due to grain, the silo being shallow was assumed to have smooth wall surfaces and friction did not exist between the wall surface and the supported grains. The wall was, therefore, only subjected to lateral grain pressure while the floor supported the entire vertical load due to grain.

Using the Rankine equation for shallow silos;

$$L = WY \left[\frac{1 - \sin \theta}{1 + \sin \theta} \right] = WY \tan^2 45^\circ - \frac{\theta}{2} \dots\dots\dots(1)$$

where

L = Lateral pressure per unit of wall area. (N/m²)

W = Bulk density of stored materials (N/m³)

Y = Difference from the top surface of grain to the point within the grain at which the pressure is considered.

θ = Angle of repose of stored materials.

Assuming the difference from the

top surface of grain to the point at which the pressure was considered was two-thirds of the height of the silo where grain was storable; 2 x 0.360 = 0.24 m.

Determination of Pressure

(a) Lateral Pressure

Lateral Pressure for the first crop (Maize) was 1.682 KN/m² from the formulae in equation 1 above. The lateral pressure for the second crop [beans] was 1.719 KN/m² while that of the third crop (sorghum) was 1.474 KN/m². For the design, the highest lateral pressure was 1.719 KN/m² (for beans).

(b) The Total Lateral Pressure

The total Lateral pressure per unit of wall perimeter is given by

$$L_T = \frac{wh^2}{2} - \frac{1 - \sin \theta}{1 + \sin \theta} = \frac{wh^2}{2} \tan^2 45^\circ - \frac{\theta}{2} \dots\dots\dots(2)$$

where h is the depth of stored grains.

The lateral wall pressure is calculated to be 0.447 KN/m²

Theoretical Average Floor Pressure: Fv = w x h (3)

This is calculated to be 2.613 KN/m².

(c) Load on the Base of the Silo

The load resting on the base of the Silo was important in estimating the deflection, and the maximum bending moment that it can withstand without collapsing. This was essentially in two parts; calculation of dead load (this was the load of the material used in constructing the Silo) and that imposed on hire load (the weight of the grains stored in the silo). The addition of these two loads was the total load resting on the base of the Silo.

Description of the Silo

Figs. 1, 2 and 3 shows the pictorial, sectional and plan views of the silo respectively. The shape of the silo was that of a frustum turned upside down. It has four stands made of hardwood 76.2 mm x 76.2 mm x 200 mm. The base of the silo was made of hardwood with a diameter of 420 mm. The silo was divided into four chambers by two intersecting 12.7 mm plywood sheets 12.7 mm thick. Each chamber has a rectangular shaped outlet covered with 6.35 m plywood of dimensions 70 by 80 m. The walls of the silo are 50 mm thick, and are reinforced with 25.4 mm by 25.4 mm by 362 mm hardwood slanted at an approximate angle of 84° to the horizontal. The walls had pozzolona and linings at a given proportion incorporated to serve as binding agents for the mud particles. The roof which was 40 mm thick and was supported by a plywood frame (6.35 mm plywood).

This frame was made of four 320 by 60 mm-plywood pieces, these are nailed together in a sequence leaving a square of 200 mm by 200 mm in the middle of the frame. The frame was nailed to the plywood demarcation and the precast roof of 380 mm inner diameter and 480 mm outer diameter was placed on it and plastered round. The cover of the silo was round and made of stainless steel which was painted white to prevent heat being absorbed into the silo and also to reduce the thermal

Table 1 Ambient temperature, temperature and relative humidity in the silo and the moisture content of the grains stored

Day	Average temperature in silo, °C	Ambient temperature, °C	Relative humidity, %	Moisture content, % (wet basis)			
				White maize	Beans	Yellow maize	Sorghum
1	32	33	93	-			
2	32	33	93	14.3	27.3	17.6	27.3
3	29	32	93	-	-	-	-
4	29	32	93	20.0	28.0	23.8	30.8
5	29	32	93	-	-	-	-
6	29	32	93	23.5	28.9	25.0	33.3
7	27	30	71	-	-	-	-
8	26	29	71	16.7	11.2	11.1	20.0
9	25	29	71	-	-	-	-
10	22	25	68	12.5	8.3	10.0	12.0
11	21	25	67	-	-	-	-
12	21	25	65	12.5	7.1	10.0	11.1
13	21	25	60	-	-	-	-
14	21	27	55	12.5	7.1	10.0	11.1
18	21	27	54	12.5	7.1	10.0	11.1
25	21	27	54	12.5	7.1	10.0	11.1

conductivity of material.

Results and Discussion

About 23 g of white maize, 23 g of sorghum, 7 g of yellow maize and 9.30 g of beans were stored in various compartments of the 30 kg capacity silo. Before the grains were stored, their moisture content were determined to know if the products are at or near the safe moisture content before storage. The moisture content (wet basis) of Sorghum, yellow maize, white maize and beans were 9.09 %, 14.29 %, 12.12 % and 18.80 %, respectively. **Table 1** gives the summary of the ambient temperature, temperature and relative humidity in the silo, and the moisture content (wet basis) of the grains during storage.

It is seen from **Fig. 4**, that the moisture content of each grain increased from the first day until the sixth day, then there was a sharp decrease until the twelfth day when the moisture content became stable. The sharp increase in moisture content until the sixth day was as a result of increased temperature from about 29 °C to 32 °C. Temperature increase resulted in a high rate of respiration of the grains during which more oxygen was consumed and carbon dioxide and water were

liberated. The water liberated caused the grains to become wet hence the increase in moisture content. As the temperature decreased from 32 °C, the moisture content decreased each day until the twelfth day when it reached a temperature of 21 °C. This was due to the fact that as temperature was reduced the respiratory activities of grains were reduced to a minimal level. The moisture given off escaped to the atmosphere through diffusion. The moisture content remained constant after the twelfth day at a temperature of 21 °C because the grains attained a state of hygroscopic equilibrium.

The sharp decrease of silo temperature with ambient temperature of the surrounding air indicated little or relatively negligible change due to the fact that mud posses a low thermal conductivity (K) of 0.00120 cal sec cm. This meant that mud conducted heat from the outside to the inside (or vice versa at a very low rate). This attribute enhanced the maintenance of a constant or near constant temperature in the mud for some time. The thermal conductivity, which is density multiplied by specific heat, was also low. The maintenance of a constant temperature in the silo was due to the fact that there was diffusion or moisture migration (even though the rate was small) from the inside to

the outer environment.

Fig. 5 shows that relative humidity was constant from the first day to the sixth day (93 %) then it decreased at a varying rate (73 % to 68 %) until the fourteenth day. From the fourteenth day the relative humidity maintained constant or near constant values (68 % to 65 %). This phenomenon was due to the change in weather. As the experiment was being performed, harmattan sets in, which accounts for the constant temperature.

Inspection of the grains during the four weeks of storage showed that there was no mouldiness observed. Also, no damage on the grain occurred due to insect infection. From the results obtained, the decrease in silo temperature indicated the absence of insect activities. This was because stocks with insect activity have unusual heat created within the silo. Mouldiness and insect activities do not thrive in relative humidity values below 75 % (Griffith, 1964). The silo did not retain a relative humidity of above 75 % for a long time, hence there was no mould or insect activity observed in the stock.

Conclusions

An experimental mud silo was

Fig. 4 Variation of moisture content with days

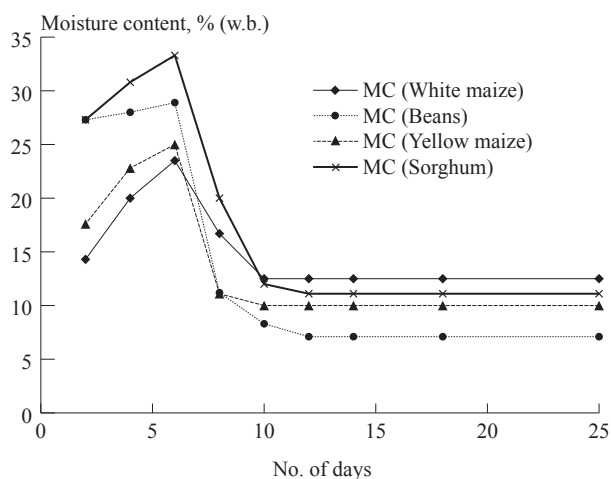
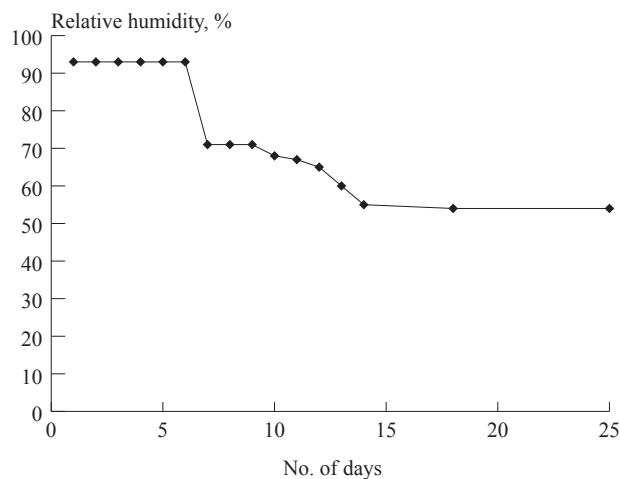

Fig. 5 Variation of relative humidity with a days



designed, constructed and tested for a period of about four weeks. The results obtained revealed the following:

- i. Relative humidity and moisture content of four grain type stored in the silo increased until a temperature of 29 °C was reached then decreased and reached hygroscopic equilibrium at a temperature of 21 °C.
- ii. The temperature outside the mud silo influenced the temperature inside the silo at a little or relatively negligible rate because of the low thermal conductivity.
- iii. No development of mould or insect activities was seen in the silo, hence the mud silo stored the grain properly.
- iv. The 30 kg capacity silo was inexpensive, the cost of construction being N700 (about \$6). An average farmer produces about 200 kg to 350 kg annually. A 500 kg capacity silo was estimated to cost only about N6000 (\$50).
- v. The materials were locally available and could easily be constructed by local farmers. No expertise was required in construction.

farm Grain Storage Facilities in Nigeria. *Agricultural Mechanisation in Asia, Africa and Latin America (AMA)*, Tokyo, 21(2): 58-60.

Ditcher, D. 1981. Improved Mud Brick Silo for storing grains. *Journal of Technology for the People*. 3 (1):18.

Griffiths, H. J. 1964. Bulk Storage of grains. *Commonwealth Scientific and Industrial Research Organization Journal*. 8 : 10-14.

Igbeka, J. C. 1983. Evaluation of grain storage techniques in Nigeria, *African Journal of Science and Technology*, 2(7) : 22-33.

Lambe, T. and R. Whitman. 1976. *Soil Mechanics*. Oxford Chamber Press, New York.

Lasisi, F. 1995. A tropical small farm storage structure for grains. *The Nigerian Agricultural Journal*, 12(1): 19-22.

Mijinyawa, Y. 1993. Lecture notes on Design Methodology for grain silo. Department of Agricultural Engineering, University of Ibadan, Nigeria.

The Holy Bible. 1995. Exodus 1:11, 5:16. King James Version. Thomas Nelson Publishers.



REFERENCES

Abdulkarim, L. O. 1988. Investigation of strength and durability of walls built of traditional earth material. Unpublished B. Eng. Project Report, University of Ilorin, Nigeria.

Babarinsa, F. A. and S. O. Nwanga. 1989. Modification of Rhumbus to enhance fumigation and increase strength. Unpublished NSPRI paper.

Bengtsson, L. P. and J. H. Whitaker. 1987. Farm structures in tropical climate. Food and Agricultural Organization Publications, (FAO) 40: 264-279.

Birewar, B. R. 1989. Existing On-

Current Status, Constraints and Potentiality of Agricultural Mechanization in Fiji

by

M. W. Ullah

Professor
Department of Soil Science and
Agricultural Engineering,
The University of the South Pacific,
Alafua Campus, Apia
SAMOA
ullah_w@samo.usp.ac.fj

S. Anad

Postgraduate Student
Department of Soil Science and
Agricultural Engineering,
The University of the South Pacific,
Alafua Campus, Apia
SAMOA

Abstract

This paper discusses the location, topography, soil type, climate, population, literacy rate and percentage of people engaged in agriculture in Fiji. The paper also briefly touches the farming systems adopted by farmers and crops cultivated including the main diet of different ethnicities. The current status of agricultural mechanization has been discussed. The constraints and potentialities of mechanization have been pointed out. Some of the constraints of agricultural mechanization have been identified as current land tenure system, poor economic condition of farmers, small holding size, fragmented holdings, cost of fossil fuel and higher cost of hiring tractors. The topography, soil type and sometimes continued bad weather also play a negative role to apply mechanization. To encourage agricultural mechanization the current land tenure system needs to be addressed as a burning issue. Some suggestions have been put forward to encourage mechanized cultivation in order to increase agricultural production at both subsistence and commercial levels. On the whole, Fiji has a huge potentiality to adopt

agricultural mechanization in farming activities.

Introduction

The Fiji island group is located in the South Pacific Ocean between East longitude 174° and 178° and South latitude 15° and 22° lying about 1,800 km to the North of New Zealand. Fiji comprises of 332 islands and islets, scattered over a million square kilometers of ocean of which approximately 110 are inhabited. Fiji has a total land area of 18,272 sq km, 85 percent of which is accounted for by two large islands, Viti Levu and Vanua Levu (Microsoft Corp., 2002). Other major islands include Taveuni, Kadavu, Koro and Ovalau. The maritime claims, measured from archipelago baselines include a continental shelf of 200 m depth or to the depth of exploitation with rectilinear self claim added, an exclusive economic zone of 200 nautical miles and a territorial sea of 12 nautical miles. The Fiji group does not have any land boundaries and has a total coastline of 1,129 km (Europa, 2000). Fiji has a population of approximately 844,330. The overall population den-

sity is about 46 persons per square kilometer. The ethnic breakup of the population includes 51 percent Fijians, 44 percent Indians and 5 percent others, which comprises Chinese, other Pacific islanders and Europeans having a literacy rate of 93.8 percent for male and 89.3 percent for female (CIA, 2000) of the country.

Agriculture is the backbone of the country's economy, accounting for 17.8 percent of the gross domestic product. For agricultural use it is the flat land and to a lesser extent the undulating and gently hilly areas are of importance. This makes the effective area for agricultural use to about 2,861 sq km of flat land and 2,842 sq km of undulating and gently hilly land. Agriculture is indeed a tough job for the farmers who have not yet practiced agricultural mechanization input. The general level of mechanization in Fiji is low. Most of the farmers use draught animals for the production of almost all crops. Animal drawn implements such as mould board plough and spike tooth harrows are employed for land preparation activities. Some small farms still use the manual system of using hand tools such as forks, spades, bush-

knives while some sugarcane growers use tractors and implements for tillage purpose (Lal, 2003). Farm work is generally labour intensive and demands a considerable amount of energy. It is laborious if carried out manually. There is a tendency for people to avoid such physical works thus affecting farming as an enterprise. That is why, from 1879 until 1916 there has been a major migration of workers from India to operate the sugar estates in Fiji. Viti Levu and Vanua Levu are the two main islands of Fiji, which may be termed as agricultural zones. Agricultural mechanization is mainly carried out in the Eastern side of Viti Levu where there is an annual rainfall of over 100 inches during the months of October to March. Also these months are regarded as the hurricane prone months. It experiences rainfall below 100 inches from April to September which is dry and cooler months in Fiji. The agricultural areas falling in the Central Division consists of the three main rivers (Rewa, Navua and Sigatoka). Majority of root crops and vegetables are grown in this area.

Objectives

The specific objectives of this study may be stated as follows:

- To study the current status of agricultural mechanization of Fiji.
- To identify the constraints of agricultural mechanization.
- To suggest some strategies for adoption to improve the pace of mechanization activities.

Topography

The larger islands in the Fiji group are of volcanic origin and are mountainous. The elevation extremes include a lowest point of zero m at sea level and the highest peak is mount Tomanivi (1,324 m). These moun-

tainous terrains are incised by many rivers. Rich alluvial soil is found in the river deltas. The smaller islands and islets are characterised by coral reef and limestone. The topography can be divided into three main classes namely flat, undulating and gentle hilly, and steep mountainous. However, the distribution of land area in different island is shown in **Table 1**. Apart from the coral atolls which usually have a larger proportion of flat land accompanied with many natural constraints like climate and soil condition most other islands have similar proportions of the three land classes. Arable agriculture is confined to flat to gently rolling areas whereas tree crops, agriculture and animal grazing are extended to relatively steep slopes. Forestry is usually confined to marginal lands of steep topography.

Climate

Rainfall

There are five broad geographical regions in Fiji that can be used to describe the climate. These can be classed as wet zone, intermediate zone, dry zone, highland and small outer islands. The main difference among wet, intermediate and dry zones is total annual rainfall. The wet zone receives over 3,000 mm of rainfall annually and have a weak seasonality of distribution. Intermediate zone receives an annual average of 2,000 to 3,000 mm rainfall with moderate seasonality. The dry zone receives an annual average of less than 2,000 mm of rainfall with a strong seasonal distribution. The highest rainfall occurs in the central

highlands of Viti Levu, Vanua Levu and Taveuni. The highland zones receive an average annual rainfall of over 3,600 mm. The small islands generally receive an average annual rainfall of less than 2,000 mm. Both Viti Levu and Vanua Levu display strong characteristics of wet and dry zones. Taveuni and Kadavu also show marked zonal differences in above factors. The intermediate zone can only be distinguished in Viti Levu and extends over a narrow band across the mid-section of the island from North East to South West.

The common rainfall pattern for all islands of the Fiji group is a uniform distribution of rainfall. The rainy season is from November to April and the dry season from May to October. In the wet zone 61 percent and in the dry zone 77 percent of the annual rainfall is received in the wet season. The wet zone has an average of 237 rainy days per annum compared to 128 rainy days per annum in the dry zone. Drought conditions are common in the dry zone and usually a prolonged drought of four to six months is common in the dry season.

Temperature

The country has a relatively mild temperature a reflection of the oceanic influence of the climate. The monthly mean maximum temperature never rises above 32 °C and the monthly mean minimum temperature never drops below 18 °C at sea level, anywhere in Fiji. There is only a small variation in monthly mean temperatures, usually about 3 to 4 °C. This variability is slightly higher in the wet zones and the small islands than in the dry zone.

Table 1 Land terrain distribution (Chandra, 1983)

Land classes	Viti levu		Vanua levu		Other islands	
	Area, sq. km	%	Area, sq. km	%	Area, sq. km	%
Flat land	1,664	16	831	15	366	15.5
Undulating and gentle hilly land	1,768	17	720	13	354	15
Steep, mountainous contry	6,968	67	3,989	72	1,640	69.5
Total	10,400	100	5,540	100	2,360	100

The smaller islands, especially the atolls, have more equitable temperatures between summer and winter months. The highland temperature is nearly 1 °C lower for every 100 m rise in altitude.

Humidity and Bright Sunshine

The relative humidity is directly related to rainfall. Ordinarily the highest relative humidity occurs in the wet highlands where it varies between 82 to 90 percent. The coastal wet zone areas and the small outer islands follow this closely. The dry zone has lowest levels of relative humidity and also a greater monthly variation between wet and dry seasons, approximately between 66 to 80 percent. Annual bright sunshine ranges from 2,507 hours in the dry zone to 1,883 hours in the wet zone. In the wet zone 46 percent of the sunshine is received in the dry season as against 52 percent in the dry zone.

Type of Soil

The parent material and climate are the two important factors that determine the nature of soils in Fiji. Other secondary criteria such as

steepness of slope and stoniness of soils have been used to differentiate soil phases within soil types. A classification of the great soil groups based on their parent materials, climate and topographic location is shown in **Table 2**.

Soil Fertility

In Fiji, some of the fertile alluvial soils are those of the floodplains of Sigatoka, Rewa, Nadi, Ba, Navua and Labasa rivers. Most of the agricultural activities are concentrated on these floodplains. Within these floodplains some of the most productive soils for arable agriculture are Sigatoka and Rewa series. Fertile hill-soils are those that originate from basic volcanic rocks. Nigrescent soils are a good example and these are found in large areas throughout Viti Levu and Vanua Levu, especially, in the dry zones. Another example is the latosolic soils of Taveuni island which is almost entirely composed of basic volcanic rocks, ash and scoria. Soils in Taveuni are extremely fertile. Humic latosols and ferruginous latosols are hill soils of low fertility and cover vast areas of the wet and dry zones of the main islands respectively. These soils have low

levels of NPK, trace elements such as sulphur and other micronutrients. Ferruginous latosols are particularly deficient in phosphorus and are most difficult hill-soils to manage. Other problem hill-soils are the red-yellow podzolics, which after leaching in the high rainfall regimes of the wet zone over a long period of geologic time, are now in a steady state of low fertility. These soils also require large inputs of fertilizer to obtain even moderate levels of production.

Drainage

Swampy conditions exist if the water table is at or near the surface. Gley soils occur in outermost areas of the floodplains next to the hills and in restricted river valleys. Gley soils are extremely important for some aspects of agriculture such as wetland rice cultivation and grazing of dairy cattle in the wet zone. Some of the agriculturally important gley soils are those of Nausori, Navua and Tokotoko series of the wet zone and Matavelo and Narewa series of the dry zone. Poorly drained soils include the red-yellow podzolic soils where the soil texture is either extremely clayey or there is existence of hardpans and organic soils. Generally, the sandy textured alluvial soils and other hill soils have good drainage. Saline soils which have sea water drainage problems and are not used for agriculture in unimproved state are sometimes reclaimed for fisheries development activities.

Slopes and Erodibility

Generally, arable farming is

Table 3 Division-wise farm area and farm population (Agricultural Census, 2001)

Divisions	Total farm area, ha	Total farm population	No. of farms	Average farm size, ha	Population per farm
Western	85,528	164,622	30,475	2.81	5.40
Central	47,611	85,516	18,699	2.54	4.57
Northern	125,032	35,291	11,072	11.072	3.19
Eastern	18,962	72,928	6,130	3.09	11.90
Total	277,133	358,357	66,376	4.18	5.40

Table 2 Soil type classification of Fiji (Chandra, 1983)

Soil groups	Parent material	Climate	Topography
1. Alluvial	River alluvium	All regions	Floodplains and deltas
2. Nigrescent	Basic sedimentary and volcanic ash	All regions	Hills and steep country
3. Latosolic	Young volcanic ash, scoria and coral limestone	All regions	Plateaus on atolls and small islands
4. Humic latosols	Acidic and intermediate volcanic rocks	Wet and intermediate zones	Hills at steep topography
5. Ferruginous latosols	Basic and intermediate volcanic ash	Dry zone	Low hills and old eroded plateaus
6. Red-yellow podzolic	Acidic volcanic ash	Wet zone	Hills and eroded terraces
7. Grey	River alluvium	All regions	Valley bottoms with impeded drainage
8. Organic	Peat	All regions	Swampy, water-logged areas
9. Saline	Coastal sand	All regions	Brackish seawater areas

confined to flat or gently sloping topography and livestock grazing is on steeper hillsides. However, steep slopes with a very thin layer of soil are often cultivated for both commercial and subsistence agriculture at a high cost of soil erosion. Under intensive rainfall conditions severe soil loss of cultivated land even on very gentle slope may be caused by sheet and gully erosion. Ferruginous latosols which have weak soil structure are particularly susceptible in this regard. Landslides and slips on steep land are common occurrence in intense rainstorms both in the wet and dry zones.

Farm Size

Farm Area and Farm Population

The total farmed area in the country is just over 277,000 ha which represents a large portion of agriculturally usable land. The number of people engaged in agriculture is also large which is about 30 percent of the total population. Altogether there are some 66,376 farms consisting of 37,975 indigenous Fijians, 25, 280 Indians and 2,581 farms of other races. The form of land tenure mostly dictates the average farm size (Gerard, 1965). **Table 3** shows the total farm area and the people involved in agriculture division wise.

There are significant numbers of very small-sized farms in Fiji. The distribution of farm sizes by division is shown in **Table 4** (Agricultural Census, 2001).

Nearly, 59 percent of all farms are below 0.50 ha and only 3.3 percent are over 20 ha. The Central Divi-

sion has an unusually large number of small farms; nearly 74 percent of all the farms are below 0.50 ha. The Northern Division and the Eastern Divisions have much smaller proportions (30 percent and 49 percent respectively) of farms less than 0.50 ha. This may be mainly due to most of the large coconut plantations are located in these divisions.

The land ownership is markedly skewed in Fiji. Although, as much as 40 percent of the farms fall in the 0-0.19 ha category, they account for less than 1 percent of the total farm area. At the other end of the distribution, only 1 percent of all farms are over 50 ha, but they represent nearly 42 percent of the total farm area. Most of the large farms consist of coconut plantations, beef and dairy cattle farms. Sugarcane, entirely commercial, farms represent nearly 26 percent of all farms and are largely operated by Indians. Village farms are those operated entirely by Fijians and are strongly subsistence oriented. Other categories include commercial, semi-subsistence and subsistence farms growing crops like pineapple, taro, cassava, ginger etc. The area occupied by the above three categories of farms are shown in **Table 5**.

Crops Grown

Since many of the areas around the central division are good for agricultural mechanization, many of the root crops and vegetable crops are commercially grown around this area. History states that this area was first brought under plantation during the early years of the development of Fiji. Even the sugar mills were first built around this area (Nausori/Suva). At present, apart from sugarcane, which is also grown in the dry land area of Viti Levu, crops such as banana, taro, pineapple, rice, yams, cocoa, ginger and vegetables are commonly grown. Root crops like taro, yams, cassava, alocasia are the main crops grown well throughout Fiji. Rice grows well in the Central Division where agricultural mechanization is mainly carried out. As such there is no single staple food but a variety of staple food in Fiji (Michael and Baxter, 1977, 1980). The experience shows that rice is the staple food for most Indian, Chinese and other races whereas staple food for the Fijians is the native root crops and vegetables. The crops grown under different farming systems are listed below. Seasonal harvest includes yams, ivi, lemons, kavika, guava, wi, jackfruit and turmeric. Regular

Table 5 Area occupied by different category of farms (Agricultural Census, 2001)

Divisions	Sugar cane		Village		Others	
	Number	Area, ha	Number	Area, ha	Number	Area, ha
Western	21,853	63,661	8,187	5,819	8,435	16,048
Central	-	-	8,345	6,592	10,349	41,019
Northern	3,133	22,492	5,775	27,952	2,164	74,589
Eastern	-	-	6,048	17,833	82	1,126
Total	24,986	86,153	28,355	58,196	21,030	132,782

Table 4 Distribution of farm size by division

Divisions	Farm size, ha										
	≤0.19	0.2-0.49	0.5-0.99	1.0-1.99	2-2.99	3.0-4.99	5.0-9.99	10-14.99	15-19.99	20-49.99	≥50.0
Western	12,770	4,164	2,073	2,152	1,766	4,110	2,265	474	81	452	166
Central	10,565	3,232	1,885	1,185	388	477	422	151	22	127	245
Northern	2,270	1,094	471	546	750	1,408	2,213	818	598	531	374
Eastern	1,221	1,753	1,164	544	186	198	482	127	156	299	-
Total	28,826	10,243	5,593	4,427	3,090	6,193	5,382	1,570	875	1,409	785

harvest of crops is only coconut.

Cropping Systems

- i. Mono-cropping
- ii. Annual cropping: Sugar cane, irrigated rice
- iii. Perennial: Coconut, cocoa, citrus, coffee, breadfruit and passion fruit
- iv. Rotational systems:
 - Annual rotation with other crops include wetland rice, dry land rice, pulses, vegetables, maize, sorghum and broomcorn, tobacco and watermelon etc.
 - Long-term rotation with fallows is used for crops like ginger, cassava, taro, yam, sweet potato, kava, masi, banana and plantains, and pineapple etc.

Agricultural Machinery Used

The type and the extent of agricultural machinery usage in Fiji is dictated by a number of factors, such as, the scale of operation (subsistence, semi-subsistence, small holder or commercial), crops grown,

farm size, topography, weather condition, available finance, access to finance and cost of machines to name a few. In addition, land tenure and the nature of distribution and location of individual farms also influence the level of mechanization. However, there are a number of mechanized operations carried out for commercial, annual as well as perennial crops. However, the number of farms using and owning different types of machinery, number of transports used for agricultural purpose and the number of animal drawn implements which portray the current status of agricultural mechanization situation may be sighted from the **Tables 6-11** shown below (Agricultural Census, 1991).

Land Preparation

Land preparation for most of the annual crops such as sugar cane, vegetables, cereals and pulses employs mechanized operations depending upon the farm size and the scale of operation. Mostly, tractors and tractor drawn mounted implements such as disc ploughs, disc harrows, spike tooth harrows, mould board ploughs, spring tine cultiva-

tors, chisel plough, ripper and drill machines are used for this purpose. For vegetable production, where a much finer soil tilth is required, rotovators and rototillers are used. For root crop cultivation such as taro and ginger, on a commercial scale, the above-mentioned machines are used. However, for village level, subsistence and smallholder farms, the land preparation is mainly done by hand tools. In places where new areas have to be cleared, heavy machines such as excavators are used to loosen up the soil and to remove large trees as these machines can be used on fairly sloping land.

Mechanization services are backed by the Ministry of Agriculture, Sugar and Land Resettlement through its machinery pool services where farmers can hire tractors and implements for land preparation. In Sigatoka valley, which is the main place for vegetable production, there is a provision for the farmers to hire tractors and implements from the Extension Division of the Ministry's office based within the valley. This service is also provided in the Rewa Delta. In addition to Governmental services there are about 6,952 privately owned tractors operating in Fiji (Agricultural Census, 1991).

Planting

Planting for the subsistence sector is mainly done by hand. This includes vegetables and all other crops. For root crops like taro, the use of spear headed steel pipe or a pitch stick is used to assist in making holes (Ullah, 1999). The use of machinery is limited due to small ar-

Table 6 Number of farms and number of power operated machinery and equipment owned

Machinery and equipment type	Number of farms	Number of machinery or equipment owned
Harrows	161	190
Milking machines (bale)	30	55
Milking machines (herring bone)	400	852
Plough	4,444	4,498
Rotary tillers	3,676	3,780
Tractors	6,419	6,952
Other	6,866	7,250

Table 7 Number of farm transports owned by types and farms

Machinery and equipment type	Number of farms	Number of machinery or equipment owned
Cars and vans	1,579	1,885
Farm lorries	2,341	2,484
Trailers	41	51
Other	8,995	10,587

Table 8 Number of farms that hired or borrowed power operated machinery and equipment

Machinery and equipment type	Number of farms
Harrows	3
Milking machines (bale)	3
Milking machines (herring bone)	88
Plough	200
Rotary tillers	191
Tractors	404
Other	624

eas of arable land, and fragmentation due to small individual holdings, especially for land under communal tenure. Planting in the commercial sector differs widely from that of the subsistence sector. Optimum plant density and spacing are closely monitored in the commercial sector. Planting is not restricted to a particular season or time. Mechanization in the commercial sector is limited to certain activities only such as land preparation (clearing and ploughing) while the actual planting is mostly done manually. On commercial farms, involved in cereals and pulses production, the primary sowing of seeds is carried out manually, as most commercial farmers believe that it is more economical to use human labour for such activities. Even for commercial scale rice planting and transplanting, as well as for sugarcane planting, human labour is the main source of power except that the furrows for sugar cane planting are made using oxen or horse with a mould board plough.

Crop Protection

The principal methods of controlling diseases and insect pests are through proper cultural practices. By tilling the soil properly, either by the use of a plough or with hoes, insect pests, larva and eggs are all made exposed to solar radiation. Working the soil also controls weed growth. Field sanitation, rouging and crop rotation techniques are also practiced for disease control as they reduce the spread of plant diseases. In high rainfall areas, good and adequate drainage provisions are made on the fields to avoid the incidence of nematodes and rot diseases. The

time of planting crops, early or late in the season also helps to escape incidence of seasonal diseases. For example, planting after rainy seasons, helps prevent the incidence of fungal diseases such as rots and wilts.

In addition to the above mentioned cultural practices, based on the traditional knowledge of the farmers, the use of chemicals for crop protection is widely adopted to compliment these practices. The agro-chemicals mostly used are selective herbicides, fungicides and insecticides for commercial farming which are also gaining popularity at smallholder's level. The equipment used to apply these chemicals is mainly the lever operated knapsack sprayers or hand sprayers for small scale farming. On commercial farms spraying with selective herbicides using motorized mist blowers is commonly practiced.

Potentiality of Agricultural Mechanization

During the 1970's most farmers in Fiji did not need to learn agriculture. This is because the old type of farming system was practiced from generation to generation by watching and helping the parents. In 1980's agricultural mechanization was introduced in the country and signs, posters and other forms of demonstrations were extended to help the farmers. The country possesses a huge potentiality to adopt selective mechanization rather than sweeping mechanization. The application of mechanization technology would increase agricultural productivity since some marginal land might be opened up for farming. Moreover, better per-

formance of the existing farms would result through timeliness of operations and minimization of avoidable losses. Consequently, labour tied up with manual farm operations would be released to higher value activities.

Constraints of Agricultural Mechanization

The choice, extent and adoption of mechanization for Fiji's agriculture have some severe limitations. Some of the constraints are mentioned below:

- The most crucial and deciding factor being the economic conditions of the farmers. A large number of farms fall under the subsistence and smallholders' sector with a very low economic turnover. As a result limited cash is reinvested back into farming. For reinvestment mechanization is mostly at the bottom of the priority list.
- The cost of fuel and machinery hiring rate has increased considerably over the last few decades making it unattractive for the farmers to hire machines.
- Holding size as dictated by the communal form of land ownership, whereby there is a lot of fragmented land owned by small individual holdings, makes mechanization almost impossible. Farming on such land is only restricted to hand-tool technology.
- Topography has also been a limiting factor for the adoption of mechanization. The use of machines for farm operations has largely been confined to flat

Table 9 Number of farm that hired or borrowed transport equipment

Machinery and equipment type	Number of farms
Cars and vans	176
Farm lorries	116
Trailers	3
Other	490

Table 10 Number of farms with number of animal drawn implements owned

Implement	Number of farms	Number of Implements
Harrow	15,649	16,215
Plough	27,160	29,713
Scarrifiers	996	1,439
Other	30,167	35,771

Table 11 Number of farms that hired or borrowed animal drawn implement

Implement	Number of farms
Harrow	246
Plough	484
Scarrifiers	33
Other	790

and gently sloping land which account for a small proportion of cropping area as flat lands have other competing demands. Heavy machines cannot be used on hilly land.

- Soil type also is an impediment to the use of machinery in many areas. For instance, some low lying areas in the Central Division are always waterlogged making mechanization impossible.
- Sometimes the prevailing weather condition also restricts the use of machines. Vegetable production requires timely operations. Prolonged rainy weather may pose a serious problem to machinery usage thus affecting timeliness of other activities later in the season.
- The availability and access to farm machines is also a major problem where the Ministry of Agriculture's tractors are in use. Usually there is a very large farmer to tractor ratio and the commercial farmers are the ones to get priority while smaller farmers have either to wait or are deprived of this service. Sometimes the delay may go up to the middle of the season because of early bookings.
- The shift in cropping systems has also played an important role in the declining machinery use. Moving to agro-forestry and zero tillage, though not very common at present, has reduced the level of mechanization to some extent.
- Expiring agricultural land lease has also caused a decline in machinery use in recent years. Currently, there are a huge number of evicted farmers who are trying to sell their tractors and implements causing a significant drop in machinery use.

Conclusions

On the whole Fiji has a huge

potentiality to adopt agricultural mechanization for increasing agricultural production. Taking the fragile nature of the island state and the conservation issues in sustainable farming into consideration adoption of mechanization input to agriculture needs to be selected wisely. The following points are suggested as accelerate the pace of mechanization:

- Hand tool technology can be improved in subsistence sector through procurement of more appropriate hand tools and developing research for such tools.
- Draught animal technology can be applied to cultivate crops which at present are entirely dependent on hand tool technology. Land preparation by digging with forks, spades and sticks can be replaced by draught animals using a mould board plough or a harrow (Smith, 1994).
- Mechanical power technology can be further improved by procurement of more appropriate machines by the government and renting out to farmers. This would open new areas for agriculture and maintain timeliness of field operations.
- Marginal land currently under no form of use may be reclaimed by using right type of machinery.
- Making appropriate and reasonably priced machines available, preferably of local origin, with adequate arrangements for maintenance facilities and spares.
- Improved land tenure system will make mechanization more attractive to farmers.
- Government may provide incentive to the interested farmers, such as, exemption of import duty on equipments, power units etc, so that they feel encouraged to import appropriate agricultural machinery for mechanization purpose.
- Adoption of machinery opera-

tions into agriculture will help reduce total reliance on labour during peak time when the demand is the highest.

REFERENCES

- Chandra, S. 1983. Agricultural Development in Fiji Australian Universities International Development Program, Australian Vice-Chancellors Committee, Canberra.
- CIA. 2002. World Fact Book Files-Fiji. <http://www.cia.org/country>
- Europa Publications Limited, (2000). The Europa. World Year Book (vol. 1). The Gresham Press, Old Working, Surrey, p 1407-1414.
- F.A.O. 2000. Food and Agricultural Organisation Year Book (54), F.A.O publication.
- Gerard, R. W. 1965. Land use and population in Fiji, University College London.
- Lal, B. 2003. Making it easier with mechanization. IRETA's South Pacific Agricultural News. July.
- MASLR. 2001. Fiji Agricultural Census Report. Ministry of Agriculture, Sugar, and Land Resettlement.
- Microsoft Corporation. 2002. Microsoft Encarta Encyclopedia-Fiji.
- Michael, W. and P. Baxter. 1977. Food in Fiji, University of the South Pacific, Suva, Fiji.
- Michael, W. and P. Baxter. 1980. Food in Fiji, (The produce and processed foods distribution systems, University of the South Pacific, Suva, Fiji.
- Smith, D. W. 1994. Testing and evaluation of agricultural machinery and equipment, Food and agriculture organization of the United Nations, Rome.
- Ullah, M. W. 1999. Present Status and Future prospects of Agricultural Mechanization in the South Pacific. Journal of South Pacific Agriculture, 6(2), p 62-70.



Performance of some Pneumatic Tires Used in Camel Carts on Sandy Terrain

by

Ghanshyam Tiwari

Professor
Department of Farm Machinery and
Power Engineering,
College of Technology and Engineering,
Udaipur - 313 001, Rajasthan
INDIA
tiwarigsin@yahoo.com



Ajay Kumar Sharma

Professor
Department of Farm Machinery and
Power Engineering,
College of Technology and Engineering,
Udaipur - 313 001, Rajasthan
INDIA

K. P. Pandey

Department of Food and
Agricultural Engineering,
Insian Institute of Technology,
Kharagpur - 721 302, West Bengal
INDIA

Abstract

Four ADV tires (5.00-19, 6.00-19, 7.00-19 and 8.00-19) and one trailer tire (7.50-19), commonly used in camel carts in Rajasthan, India were evaluated under controlled soil bin conditions in sand at different levels of inflation pressure, normal load and soil compaction. Among the tested tires 7.00-19 tire performed better, however its use in camel carts may not be recommended beyond the payload of 600 daN on single wheel within the inflation pressure and soil compaction range of 172.5 to 379.5 kPa and 3.4 to 4.5 MPa/m respectively. The developed second order regression model predicts the rolling resistance fairly well within the tested range of various parameters.

Introduction

Animal energy is the principle source of motive power in Indian farming. Animal drawn ploughs and vehicles are an important part of Indian scene and are several generations older than its oldest tree. Animal power is used for various farming operations such as ploughing, sowing, interculture, threshing, water lifting etc. During the last two decades the growth of mechanization in Indian agriculture has been comparatively rapid. Still the draught animals continue to be the predominant source of renewable energy for traction and rural transport.

The western part of India is famous for "Thar Desert" with Rajasthan comprising its major portion (259,000 km²). The camel is a highly suitable animal for desert or arid

zones because of its unique qualities of withstanding drought conditions and living for days together without water. There are 1.3 million camels out of total population of 84 million work animals in the country, which is about 7 percent of the global camel population. Rajasthan has the maximum number of camels and accounts for about 60 percent of the total population of India.

The camels are used not only as draught animal for various farm operations but also as a source of power for haulage of goods, water and passengers in desert areas of the state. Goods are transported on the back of camels as well as the carts pulled by them. The camel cart is a main source of transport in villages in the desert area of Rajasthan. The carts are extensively used for passenger transport as well as for hauling all sorts of cargoes, i.e. such

as farm produce, water tank and building material. A single camel is used to provide draught power to desert carts fitted with two or four pneumatic wheels (**Fig. 1**). Animal drawn vehicle (ADV) tires, which are commonly used in these carts were considered in the study. A similar size tire used on trailers was also studied along with ADV tires.

The performance characteristics of a towed wheel are usually described by towing force, i.e. rolling resistance, sinkage and skid. The rolling resistance is the most important performance parameter of the towed pneumatic wheel, which is influenced by tire design, system parameters and terrain characteristics. The present study deals with the behavior of the towed pneumatic wheels on sandy terrain.

Material and Methods

Different sizes of pneumatic wheels (**Table 1**) which are used in camel carts were selected for evaluating their performance (**Fig. 2**). The tire design parameters such as diameter, section width, section height, inflation pressure, carcass construction and load deflection relationship and system parameters such as normal load, speed and terrain characteristics play a vital role on performance of pneumatic towed wheels. Considering the findings of various researchers (Singh and Verma, 1987; Jain, 1987; Shrimali, 1990, ILO, 1986; Verma, 1991) a study was conducted for performance evaluation of different ADV and a trailer tire in sandy terrain (**Table 2**). The range of various pa-

rameters were selected taking into consideration the normal values observed in the field except the inflation pressure which reflects the maximum and minimum range as recommended by the manufacturer.

Experimental Techniques

A single tire test carriage with a four parallel bar linkage system was developed to test the tires. Experiments were conducted in the indoor soil bin in sand to evaluate the performance of tires at different normal loads, inflation pressures and soil compaction levels (**Figs. 3 and 4**).

Test Procedure

Before each test, the soil bed was processed using the soil processing trolley. A hand operated standard soil cone penetrometer was used to measure the cone index of the soil at five different places in the depth range of 0-150 mm. The soil processing was repeated if large variation in compaction level was observed. From the recorded observations, the cone index gradient was calculated by using the expression:

$$G = \frac{CI_{av} - CI_{surf}}{1/2 \times \text{depth of interest}} \dots\dots(1)$$

where

G = cone index gradient, MPa/m;

CI_{av} = average cone index, MPa and

CI_{surf} = cone index at surface, Mpa.

The towing trolley attached with tire test carriage was coupled with the soil processing trolley through a ring transducer (**Fig. 3**) to record the towing force, i.e. rolling resistance. Replicated tests were conducted at a forward speed of 3.1 km/h to

Fig. 1 Two wheeled camel cart

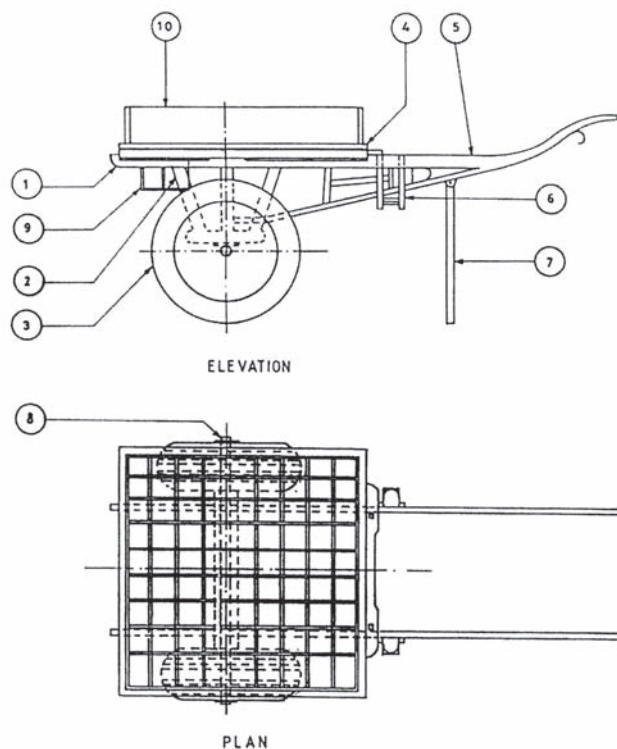

7	Front support	Wood			
6	Foot rest	Wood			
5	Pull beam	Wood			
4	Platform	Wooden plank/ M.S. sheet			
3	Pneumatic tyre	Rubber	10	Side panel	Wood
2	Axle mounting bracket	Wood/M.S. angle	9	Tool box	Wood
1	Body frame	Wood / M.S. angle	8	Axle	M.S. square/ round
SL.NO.	DESCRIPTION	MATERIAL	SL. NO.	DESCRIPTION	MATERIAL

Fig. 2 Test tires

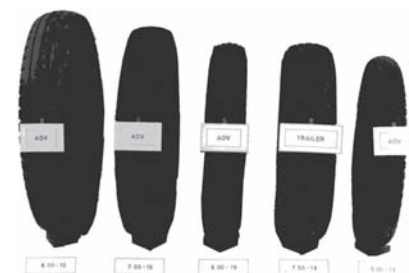

cover a length of 5.5 m in the soil bin using factorial RBD and rolling resistance was recorded using a 2 channel dynograph recorder.

Results and Discussion

The performance of four ADV tires and one trailer tire was evaluated in sand based on their deflection characteristics the tires TA₁ and TA₂ were tested at 200, 400 and 600 daN normal loads while the tires TA₃, TA₄ and TT₅ were tested at five normal loads (200, 400, 600, 800 and 1000 daN). **Figure 5** shows the typical curves of variation in rolling resistance of ADV and trailer tires at different normal loads, inflation pressures at a given soil compaction level.

Effect of Normal Load on Rolling Resistance

The trends of the curves (**Fig. 5**) indicate that the rolling resistance increased with the increase in normal load at all inflation pressures and soil compaction levels for all tires. The results confirm the findings of McAllister et al. (1981). Less rolling resistance at low normal loads can be attributed to sufficient soil strength to support the wheel with insignificant sinkage. The wheels have neither to overcome the

resistance offered by the surface in compacting it nor shearing it. The force due to adhesion is the only factor, and hence the rolling resistance is reduced to a large extent.

Effect of Inflation Pressure on Rolling Resistance

In general the rolling resistance of all the tires increased with inflation pressure at all the normal loads and soil compaction levels studied (**Fig. 5**). The rolling resistance was minimum at an inflation pressure of 172.5 kPa and it increased rapidly with increase in inflation pressure up to 310.5 kPa. Further increase in inflation pressure did not show ed little difference in the rolling resistance. Similar trends were also observed by Mckibben (1940), Janosi (1961), McAllister (1979), Wong et al. (1984) and Verma and Singh (1994). The increase in rolling resistance may be explained as follows:

1. The tire stiffness increases with inflation pressure due to which tire does not deform significantly and it works as a rigid wheel beyond a certain inflation pressure. The resistance in such case depends only on load.
2. At lower inflation pressure the tire deforms rather than sinks, thus yielding less resistance and more ground contact area than a tire with higher inflation pres-

sure.

Effect of Terrain Condition on Rolling Resistance

It was observed that with increase in compaction level of sand, the variation in rolling resistance of the tire was much less. The data also indicated that the increase in compaction level of soil from 3.4 to 4.0 MPa/m did not affect the rolling resistance of tires significantly at all normal loads and inflation pressures. This may be due to insignificant variation in supporting strength of soil with change in compaction level within this range.

Effect of Tire Size on Rolling Resistance

It is interesting to note that in general rolling resistance decreased with increase in the size of tire. This is in conformity with the findings of Mckibben et al. (1940) which states that the contact area of the tire effects the rolling resistance significantly. Out of five tires tested the tire TA₁ indicated the maximum rolling resistance at all loads, inflation pressures and soil compaction levels. This may be attributed to its narrow area of supporting contact surface due to which the tire failed to hold enough volume of soil under compression resulting in increased sinkage and thereby rolling resistance. At lower normal loads (200-400 daN), the minimum rolling resistance was indicated by the tire TA₄ (15-70 daN) while at higher loads of 600-1000 daN, it was indicated by tire TA₃ (45-130 daN) in the range of inflation pressures and

Fig. 3 Schematic diagram of experimental set-up

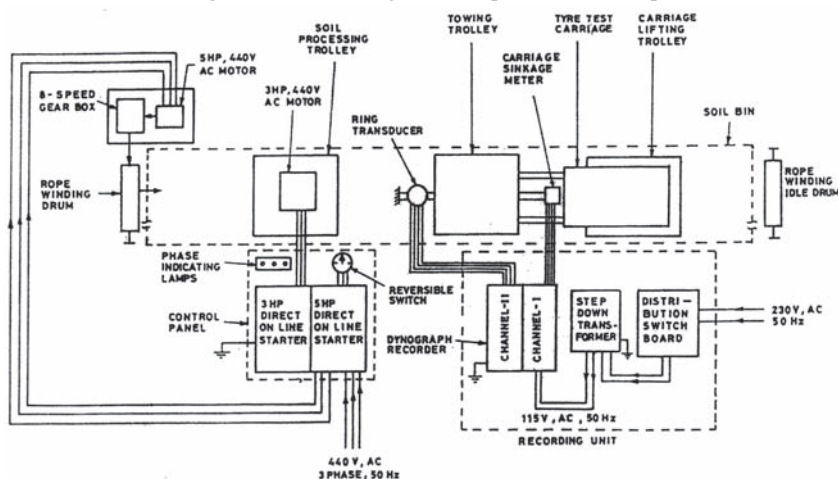
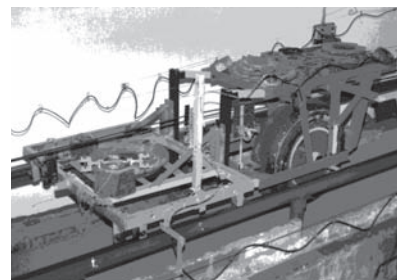

Fig. 4 Experimental set-up



soil compaction studied.

It can be seen from **Table 1** that the tires TA₂ and TT₅ have almost the same diameter but their width differs significantly. Comparing the performance of these tires, it was observed that the rolling resistance of tire TT₅ was lower than that of tire TA₂ under different loads and inflation pressures. This may be due to greater width of tire TT₅, which helped in decreasing the wheel sinkage and thereby the rolling resistance. This behaviour is in close agreement with the findings of Bekker (1956) and McAllister et al. (1981).

Comparing the performance of tires TA₃, TA₄, and TT₅, it is noticed that, though the width of the tires is almost the same, but their diameters differ significantly. The large diameters of TA₃ and TA₄ resulted in decreasing the rolling resistance of these tires as compared to TT₅. Similar trends were also observed by Mckibben (1940), Turnage (1972), McAllister et al. (1981) and McAllister (1983). The decrease in rolling resistance with wheel diameter may

be explained on the basis of the fact that at large wheel diameters the ground pressure is relatively low which helps in reducing the rolling resistance due to failure of soil mainly in compression.

Comparative study of tires indicated that the overall performance of TA₃ was better than that of the other four tires. The minimum and maximum values of rolling resistance were in the range of 16-69 daN and 21-130 daN respectively for the test parameters used in the study. The results indicated that the upper range of the minimum rolling resistance of the tire TA₃ is 68 daN, which is beyond the draft capacity of a single camel (80-100 daN) is generally employed to pull a two wheeled cart. The maximum loading capacity for TA₃ is therefore, recommended to be less than 600 daN in sandy terrain.

Modeling the Results

An empirical model was devel-

oped for prediction of rolling resistance of various tires tested in the study. Utilizing the experimental data, a multiple regression analysis was carried out to investigate the combined effect of inflation pressure (P_i), normal load (W), soil compaction (G) and tire b/D ratio on rolling resistance (R). The following second-degree polynomial equation was found to estimate the rolling resistance.

$$R = 403.64 + 0.265P_i + 0.171W - 4026.9(b/D) - 0.00057P_i^2 - 0.0001W^2 + 8532.2(b/D)^2 + 0.00024P_iW + 0.347P_i(b/D) \dots\dots\dots(2)$$

$$(R^2 = 0.95, F = 641.20^{**})$$

The high value of coefficient of determination indicate that the observed data could be accurately predicted by the proposed model.

Optimization of Tire Design and Soil Parameters

Using the multiple regression equation the tire design and soil parameters were optimized for minimum rolling resistance. A computer programme based on search technique was used for optimization of independent parameters and results are presented in **Table 3**.

It is noticed from the **Table 3** that the optimum b/D ratio for ADV tire is 0.232, which corresponds to a tire size 7.00-19.

Conclusions

1. The overall performance of the tire 5.00-19 and 6.00-19 was inferior to that of the tires 7.00-19, 8.00-19 and 7.00-16. The poor performance of 5.00-19 and 6.00-19 tires indicated their unsuitability in sandy terrain.
2. The minimum rolling resistance was indicated by the tire 7.00-19. However, its use in camel carts may not be recommended beyond the payload capacity of 600 daN on a single wheel.

Table 1 Specifications of tires used in the study

Sl. No.	Type of tire	Tire code	Tire size	Diameter (D), mm	Section width (b), mm	Section height (h), mm	b/D
1	ADV	TA ₁	5.00-19, 4PR	745	130	115	0.174
2	ADV	TA ₂	6.00-19, 8PR	790	160	125	0.202
3	ADV	TA ₃	7.00-19, 10PR	850	200	160	0.235
4	ADV	TA ₄	8.00-19, 10PR	890	220	190	0.247
5	Trailer	TT ₅	7.50-16, 10PR	795	210	175	0.264

Table 2 Various parameters considered in the study

Variables	Levels	Values
Independent variables		
Tire size	5	5.00-19, 6.00-19, 7.00-19, 8.00-19, 7.50-16
Inflation pressure, kPa	4	172.5, 241.5, 310.5, 379.5
Normal load, daN	5	200, 400, 600, 800, 1000
Soil compaction, MPa/m	3	3.4, 4.0, 4.5
Forward speed, km/h	1	3.1 km/h
Dependent variable		
Rolling resistance, daN	-	

Table 3 Optimum values of tire design and soil parameters

Optimum values of independent parameters			Rolling resistance, daN
b/D	P _i , kPa	G, MPa/m	
0.232	172.5	3.4	82.35

REFERENCES

Bekker, M. G. 1956. Theory of land locomotion. Ann Arbor, M.I.: University of Michigan press.

International Labour Organisation. 1986. The design and manufacture of animal drawn carts. Intermediate Technology Publication, London.

Jain, A. K. 1987. Testing of camel carts of Rajasthan. Unpublished M.E. thesis, Rajasthan Agricultural University, Bikaner, Rajasthan, India.

Janosi, Z. 1961. An analysis of pneumatic tire performance on deformable soils. Proc. of the 1st Int. Conf. On mechanics of soil vehicle systems. Edizioni Minerva

Tecnica, Tormo: 737-771.

McAllister, M. 1983. Reduction in the rolling resistance of tires for trailed agricultural machinery. J. Agric. Engng. Res. 28:127-137.

McAllister, M., D. Gee-Clough, and D. W. Evernden. 1981. An investigation into the rolling resistance of undriven wheels. Dept. note DN/1075, NIAE, Silsoe.

McAllister, M., D. Gee-Clough, and D. W. Evernden. 1979. Preliminary results obtained from an investigation into rolling resistance of towed wheels. Dept. note DN/T/917/01002, NIAE, Silsoe.

Mckibben, E. G. and J. B. Davidson. 1940. Effect of inflation pressure on the rolling resistance of pneumatic implement tires. Agricul-

tural Engineering 21(1): 25-26.

Mckibben, E. G. and J. B. Davidson. 1940. Effect of outside and cross-sectional diameter on the rolling resistance of pneumatic implement tires. Agricultural Engineering, 21(1): 57-58.

Shrimali, H. 1990. Testing of two wheeled camel carts used in desert tracts of Rajasthan. Unpublished M. E. thesis, Rajasthan Agricultural University, Bikaner, Rajasthan, India.

Singh, P. and R. N. Verma. 1987. Survey of carts used in desert tract of Rajasthan. Paper presented in 23rd annual convention of ISAE, Jabalpur, India.

Turnage, G. W. 1972. Tire selection and performance prediction for off-road wheeled vehicle operations. Proc. of the 4th Int. Conf. of the ISTVS, Stockholm, Vol. 1: 61-82.

Verma, A. 1991. Comparative performance study of different types of pneumatic wheels for two wheel camel carts. Unpublished M.E. thesis, Rajasthan Agricultural University, Bikaner, Rajasthan, India.

Verma, A. K. and P. Singh. 1994. Effect of inflation pressure and payload and draught requirement of two wheeled camel carts on sandy terrain. J. of the Institution of Engineers (India), 75: 34-37.

Wong, Z. and A. R. Reece. 1984. The performance of free rolling rigid and flexible wheels on sand. J. Terramechanics 21(4): 347-360.

Fig. 5 Performance of test tires at different normal loads and inflation pressures in sand at compaction level 3.4 MPa/m

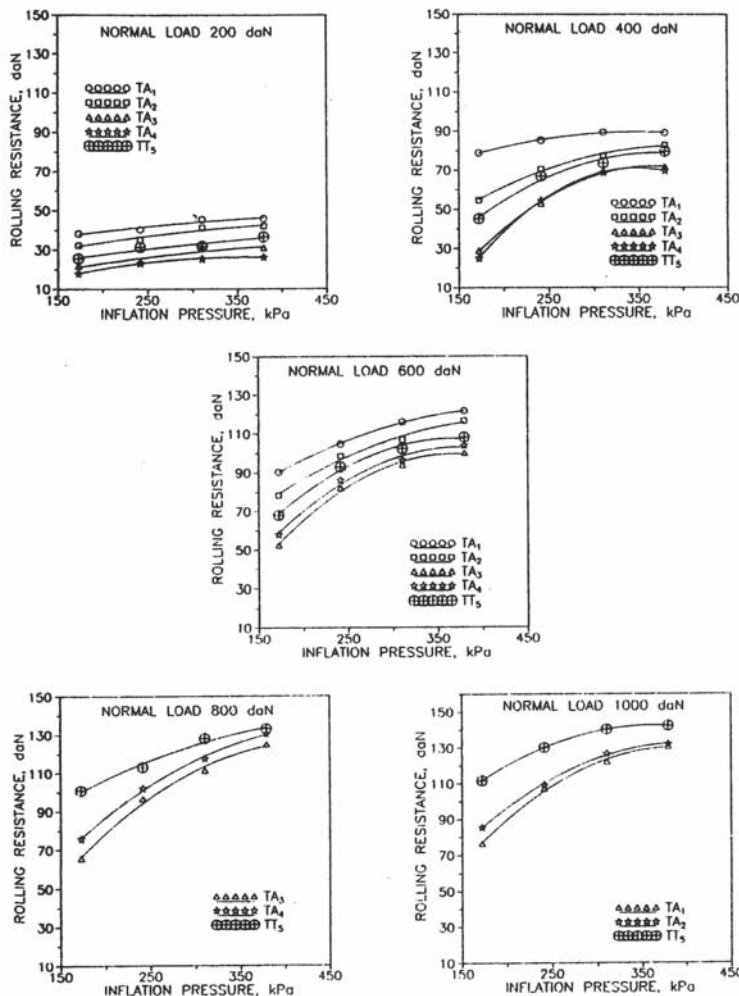

Feasibility of Collecting Ambient Air Moisture by Forced Condensation

by

Hamid Al-Jalil

Associate Professor
Department of Biosystems Engineering
and College Engineering,
Jordan University of Science and Technology,
P.O. Box 3030, Irbid 22110
JORDAN
aljalil@just.edu.jo

Jumah Amayreh

Department of Biosystems Engineering
and College Engineering,
Jordan University of Science and Technology,
P.O. Box 3030, Irbid 22110
JORDAN
jume@just.edu.jo



Mohamad Al-Widyan

Associate Professor
Department of Biosystems Engineering
and College Engineering,
Jordan University of Science and Technology,
P.O. Box 3030, Irbid 22110
JORDAN
widyan@just.edu.jo

Abstract

This work investigated the feasibility of collecting ambient air moisture. A dehumidifying unit of 215 watts was used to condense and collect moisture. A rain gage recorded the collected moisture. Dry bulb temperature and relative humidity (RH) were recorded plus the instantaneous voltage and current. A data logger recorded data on an hourly basis. There was positive correlation between ambient RH and moisture collection rate. Up to 137.2 ml of water/hr were collected with efficiency of 0.822 liters/kW hr at 14.0 °C and RH of 87.4 % resulting in a

Acknowledgements: Appreciation is due to Jordan University of Science and Technology, Irbid-Jordan for their financial support through project No. 74/2000.

cost that compares favorably with the local rate of bottled water.

Introduction

Jordan lacks credible readily available water resources. In addition, most of the country lies in a semi-arid to arid region where the annual average rainfall is below 200 to 250 mm. In the last few decades, substantial increase in the country's population, rising living standards, and expanding industry and irrigated-agriculture resulted in drastic increases on water demand. Further, it is established that water resources available in the region will witness serious competition among different nations. Based on the discussion above, making any additional water resources available is of extreme importance.

Water may be made available by different means including rational use, reuse of treated wastewater, or creating new resources. The significance of this research is to create a potentially new water resource by collecting ambient air moisture. The quality and quantity (availability) of this source are, respectively, good

Fig. 1 Moisture recovery system

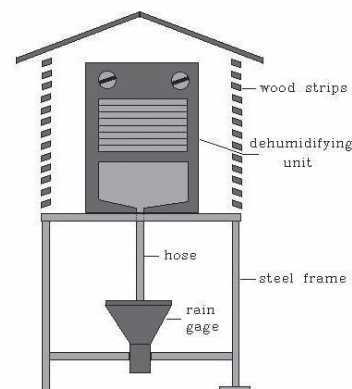

and at least theoretically unlimited. This approach may be particularly invaluable for water collection in remote areas where providing water utilities is too expensive.

Various forms of water harvesting have been practiced for thousands of years in areas where rainfall is the only source of water supply. Today, water harvesting is still practiced in many developing countries as a way of supplementing the normal water supply. Some methods of water interception in common practice include the use of roofs, courtyards and ground catchments (Abu-Zreig, 1999). In arid and semi-arid areas where rivers and lakes are few and scarce, much experimentation has been done on the collection of fog

and dew to supplement water supply. Plastic meshes were used for collecting water from fog and mist. For example, in the village of Chungongo in Chili, which lies in an arid area, the earliest fog and mist collection systems provided 11,000 liters of good-quality water from its numerous collectors. Similar systems have been successful in other regions in Ecuador, Peru, Oman, and the Canary Islands (Cutlip, 1997). Dew collectors may be as simple as wooden planks or a pile of stones supported above the ground or they may be made of newly-developed materials with enhanced properties such as polymer foils. Even the simplest dew collector can gather up to 0.4 liters per square

meter per night (Nikolayev et al., 1996; Nilson, 1996; UNEP, 1979).

The literature searched indicated that all collection techniques have relied on the natural condensation of fog or mist from the ambient air. However, forced condensation of dew or mist for the purpose of water collection was not tested by existing systems. Consequently, this research effort was initiated with the goal of examining the feasibility of collecting ambient air moisture by forced means. In specific terms, this work involved investigating the moisture collection process in terms of quantity, the influence of major psychrometric parameters on the process, and comparing the costs with the local average rates of water supply.

Fig. 2 Temporal variation of moisture collected with humidity and temperature (day 1)

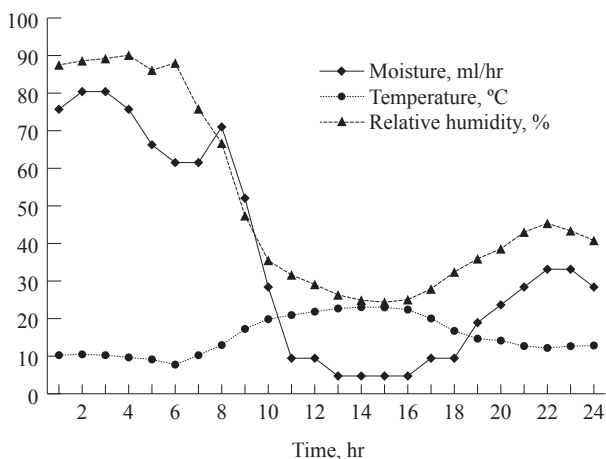

Fig. 3 Temporal variation of moisture collected with humidity and temperature (day 2)

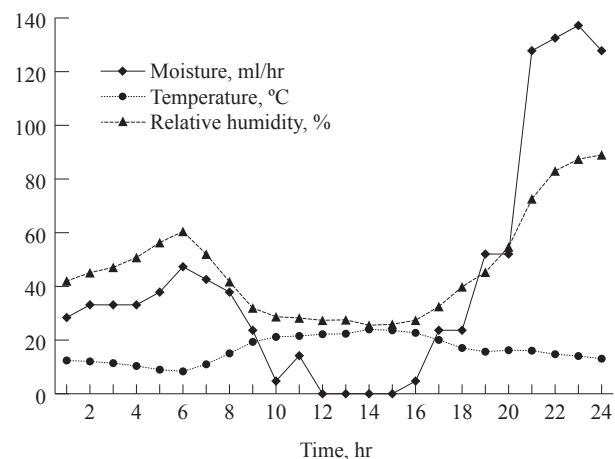

Fig. 4 Temporal variation of moisture collected with humidity and temperature (day 3)

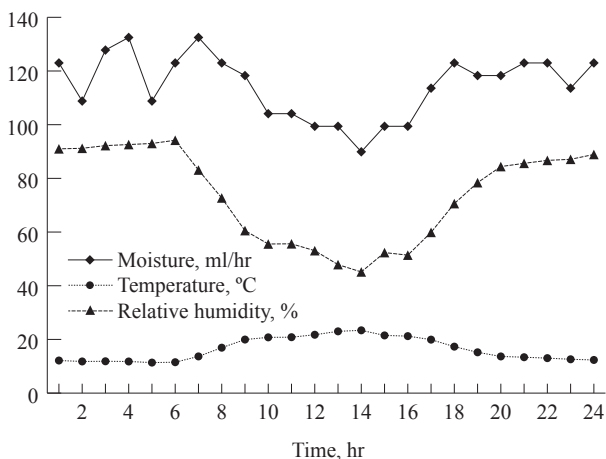
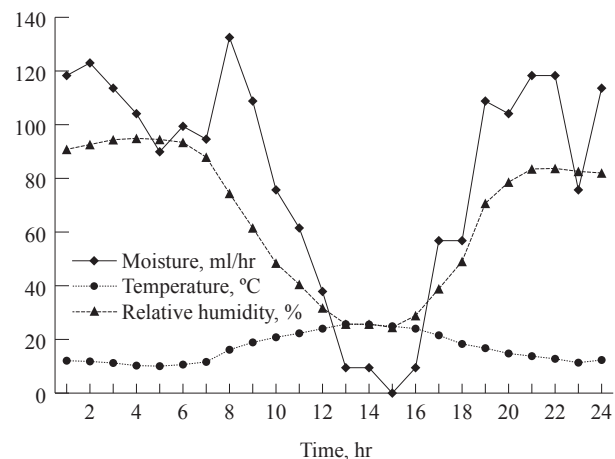

Fig. 5 Temporal variation of moisture collected with humidity and temperature (day 4)



Experimental Procedure

Ambient air moisture was collected by forced condensation. The system was installed in an open area on J.U.S.T campus, which is among the driest regions in Northern Jordan. Thus, if the system works in this location, it is expected to be much more promising in many other regions in the country where air is more humid. A small dehumidifying unit of 215 watts was used to provide a cold surface below the dew point under prevailing ambient conditions.

The unit was equipped with a humidstat and a two-speed air fan. The humidstat controled the operation and shutting down of the unit at prescribed levels of air moisture content (relative humidity). The air fan passed the ambient air over the cold surface and the moisture in contact with this surface would condense and then be collected. Specially designed wooden housing was used to protect the unit from the environment. The housing and the unit were mounted on a 1-meter high steel frame as shown in **Fig. 1**.

A small tank located under the cold surface was used to collect the condensed water. The amount of collected water was detected using a rain gage (Model TR-525M) attached to the steel frame underneath the unit. A rubber hose was used to conduct the collected water from the tank to the rain gage by gravity.

The ambient relative humidity and dry bulb temperature were also recorded using Vaisala probe (Model HMP35C) mounted at 1.5 m height. The instantaneous voltage and current were detected using a specially designed electrical circuit. The total energy consumption was measured by a power meter. The system was run for a total of 96 hours in such a way that they represented the typical range of seasonal variations in the local weather conditions. The dry bulb temperature ranged from 7.7 °C up to 25.7 °C while the relative humidity ranged from 24.5 % to 94.9 %.

A data logger (Model 21X, Cambell Scientific, Inc.) was programmed to record the sensed signals on an hourly basis. The recorded data were processed and analyzed by the computer using Excell software to determine the effect of relative humidity, temperature and other relevant variables on the rate of water collection.

As the moisture collection in this work was by forced means, it was elected to express the feasibility of the collection process by a collection efficiency term defined as the amount of water collected in liters per unit energy consumed in kW hr.

ported in **Figs. 2** through **9**. In all figures, the horizontal axis represents a 24-hour time span starting midnight to midnight next day. The general trends of temperature and relative humidity in the figures are attributed to day and night variations. **Figs. 2, 3, 4** and **5** show the effect of dry bulb temperature and relative humidity of ambient air on moisture collection. In general, there was a close correlation between the relative humidity and the rate of moisture collection. As expected, the higher the ambient relative humidity the higher the rate of moisture collection. It was found that an amount of up to 137.2 ml of water could be collected in one hour at average ambient temperature of 14.0 °C and relative humidity of 84.4 %. The efficiency of collection expressed in liters of water per kW per hour was calculated to be 0.822 under these conditions.

The temperature at a given relative humidity was observed to have a positive influence on the rate of moisture collection, specifically, the higher the temperature the higher the rate of moisture collection. This is attributed to the fact that for the same relative humidity, the absolute amount of moisture in air is higher at a higher temperature than at a lower one.

Figures 6 through **9** show the corresponding accumulated moisture collection. The slope of these

Results and Discussion

The results of this study are re-

Fig. 6 Temporal variation of accumulated moisture with humidity (day 1)

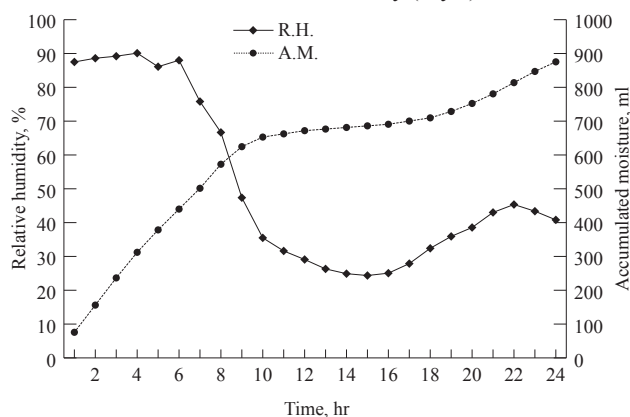
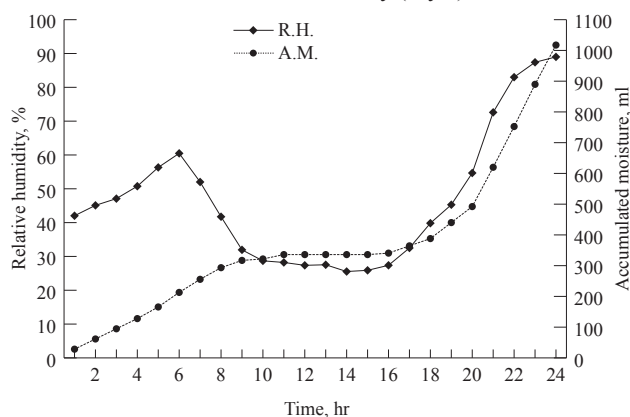

Fig. 7 Temporal variation of accumulated moisture with humidity (day 2)



curves represent the rate of moisture collection in ml/hr. These curves confirm that the rate of moisture collection increased as the relative humidity increased. The trends reported in all cases except for the humid day (day 3) indicated that, in general, the rate of moisture collection in daytime especially at noon was almost leveled indicating a very poor collection rate. Specifically, during all test runs, the unit failed to condense air moisture below 24 % relative humidity. This may be due to the fact that under low humidity ratio conditions, the dew point gets significantly lower beyond the cooling capacity of the unit.

The data indicated that the current and voltage signals showed very little variation during the test, which implies that the power consumption was steady during the test and was independent of ambient conditions and collection rates. The total energy consumed during the test was about 16.0 kW hr.

The feasibility of moisture collection process in this work was evaluated by estimating the cost per unit water volume collected. The data indicated that based on power consumption, the cost under average weather conditions was about \$0.123 per liter while under favorable conditions the cost was about \$0.06 per liter. These figures compare favorably with local common rates of good quality bottled drink-

ing water, which range from \$0.35 to \$0.49 per liter.

Conclusions

The following conclusions may be drawn from the results of this study.

1. The collection process was very efficient under higher levels of relative humidity and the moisture collected over time followed the same trend as that of the relative humidity.
2. The system collected up to 137.2 ml of water in one hour at an average ambient temperature of 14.0 °C and relative humidity of 84.4 %. The efficiency of collection was found to be 0.822 liters/kW.hr under these conditions.
3. For the same relative humidity, the system collected more moisture at higher temperatures compared to lower ones reflecting a positive influence of higher temperatures at any given relative humidity.
4. The unit failed to condense moisture below 24 % relative humidity during the test period.
5. Under the prevailing local conditions, the system was much more efficient at night compared to daytime.
6. Power consumption was steady throughout the test and was independent of ambient condi-

tions and the cost of a unit water volume collected by the system compares very favorably with local cost of bottled drinking water.

REFERENCES

- Abu-Zreig, M. 1999. Water harvesting techniques to increase agricultural sustainability on arid regions. SDR International Conference, Nov. 20-22, Al-Ain, UAE.
- Cutlip, K. L. 1997. Fog on tap. *Weatherwise* Vol. 50, Issue 2 p 8. Heldref Publications.
- Nikolayev, V. S., D. Beysens, A. Giodo, and K. Milimouk. 1996. Water recovery from dew. *Journal of Hydrology* Vol. 182: 19-35.
- Nilson, T. 1996. Initial experiments on dew collection in Sweden and Tanzania. *Solar Energy Materials and Solar Cells* Vol. 40(1): 23-32, March, 1996.
- United Nations Environment Programs. 1979. Rain and Storm Water Harvesting for Additional Water Supply in Rural Areas. Expert Group Meeting, Nairobi.



Fig. 8 Temporal variation of accumulated moisture with humidity (day 3)

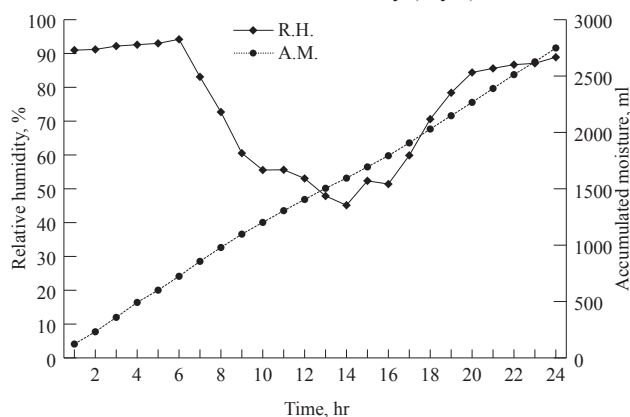
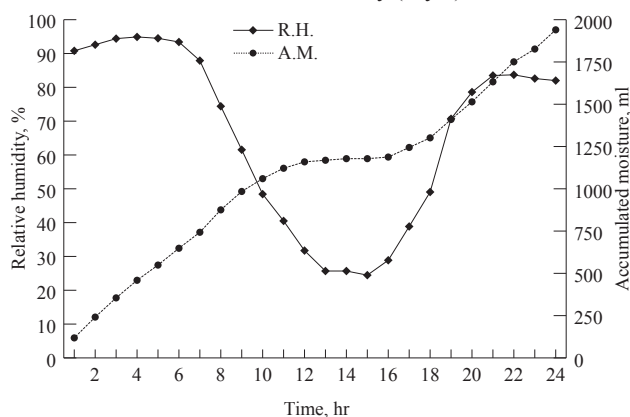

Fig. 9 Temporal variation of accumulated moisture with humidity (day 4)



Energy Cost of Riding and Walking Type Power Tillers

by

Binisam

Ph. D. Scholar
Agricultural Engineering College
and Research Institute,
Tamil Nadu Agricultural University,
Coimbatore - 641 003
INDIA



K. Kathirvel

Professor and Head
Agricultural Engineering College
and Research Institute,
Tamil Nadu Agricultural University,
Coimbatore - 641 003
INDIA



R. Manian

Dean
Agricultural Engineering College
and Research Institute,
Tamil Nadu Agricultural University,
Coimbatore - 641 003
INDIA

T. Senthikumar

Ph. D. Scholar
Agricultural Engineering College
and Research Institute,
Tamil Nadu Agricultural University,
Coimbatore - 641 003
INDIA

Abstract

The ergonomic aspects of the power tiller are of great importance as working with the power tiller involves considerable physiological strain to the operator. The physiological response of the subject while operating two power tillers with one as walking type (7.46 kW) and the other as riding type (8.95 kW) was investigated. The selected operations included rotary tilling in untilled and tilled fields and transport on farm and bitumen roads. The selected levels of forward speed of operation were 1.5, 1.8, 2.1, 2.4 km h⁻¹ and 3.5, 4.0, 4.5, 5.0 km h⁻¹ for field and transport operations respectively. Three subjects were selected based on the age and weight and screened for normal health through medical investigations. The physio-

logical cost of power tiller operation was computed and the energy cost of work was graded. The oxygen uptake in terms of VO₂ max was compared with acceptable workload and the work pulse was compared with limit of continuous performance. For rototilling in an untilled field the energy cost of work varied from 17.13 to 20.09 kJ min⁻¹ for the walking type (7.46 kW) power tiller and 13.95 to 15.43 kJ min⁻¹ for riding type (8.95 kW) power tiller. In the tilled field the values varied from 15.70 to 18.23 kJ min⁻¹ and 13.28 to 14.59 kJ min⁻¹, respectively. The operations were generally graded as "moderate work". The rototilling operation in an untilled field was strenuous as it demanded 9.1 to 10.20 percent and 1 to 6 percent more energy for walking type (7.46 kW) and riding type power tillers

(8.95 kW), respectively than in a tilled field. Power tiller with seating attachment resulted in saving of 23 to 30 percent and 18 to 25 percent human energy requirement in untilled and tilled fields, respectively. In transport mode the energy cost of work varied from 10.17 to 11.12 kJ min⁻¹ and 11.32 to 12.82 kJ min⁻¹ with 7.46 kW and 8.95 kW power tillers, respectively. The operation was generally graded as "light work" to "moderate work". When compared to the 8.95 kW power tiller, the 7.46 kW power tiller resulted in savings of human energy requirement of 15.33 to 16.23 percent on farm roads and 4.9 to 11.3 percent on bitumen road. For field operation with the walking type power tiller, the oxygen uptake in terms of the oxygen consumption rate (VO₂) max varied from 35.30 to 43.93 percent

which was above the acceptable work load whereas the values varied from 29.04 to 33.74 percent for the riding type (8.95 kW) power tiller and was within the acceptable workload. During transport mode, oxygen uptake in terms of VO_2 max varied from 22.24 to 28.03 percent and the values were within the acceptable limit for both power tillers. The work pulse (Δ HR) varied from 21.08 to 37.79 percent for field operations and 11.42 to 19.88 for transporting operations and were within the limit of continuous performance.

Introduction

The ergonomic aspects of power tillers are of great importance as working with the power tiller involves considerable physical strain to the operator. Controlling the power tiller while turning causes considerable fatigue to the operator. An operator has to walk behind the machine for a distance of about 15 to 20 km, merely to rototill a hectare of land once. The problem is aggravated when walking behind the machine in puddled soil during the rototilling operation in rice fields (Mehta et al., 1997). The working performance of a power tiller depends not only on the machine but also on the operator. If ergonomic aspects are not given due consideration, the performance of the man-machine system will be poor and effective working time will be



Fig. 1 View of the measurement of heart rate during the operation of power tiller B in untilled field

reduced. On the other hand, due to heavy demand on the worker's biological systems, the power tiller operation results in clinical and anatomical disorders and in the long run, will affect the workers health (Tiwari and Gite, 1998). In the present study the energy cost of operating walking and riding type power tiller was compared and reported.

Review of Literature

The heart rate for power tiller tillage operation was observed in the range of 105 beats min^{-1} to 114 beats min^{-1} . The corresponding human energy requirement was in the range of 13.22 to 20.52 $kJ\ min^{-1}$ (Pawar, 1978). Kathirvel et al. (1991) observed that energy expenditure of power tiller operation varied from 13.48 to 25.83 $kJ\ min^{-1}$ during rototilling operation under different operating conditions. The heart rate was used as the index of physiological cost. Mc Ardle et al. (1994) reported that energy expenditure during walking was influenced by the walking speed and terrain conditions. Tiwari and Gite (1998) measured heart rate and oxygen consumption of the power tiller operators during rototilling operations under actual field condition. The mean values for human energy expenditure during rototilling operations were 10.02, 12.11 and 13.15 $kJ\ min^{-1}$ at the forward speeds of 1.09, 1.69 and 2.26 $km\ h^{-1}$ respectively.



Fig. 2 View of the measurement of heart rate during the operation of power tiller A with trailer attachment on farm road

Mamansari and Salokhe (1999) assessed the physiological cost of the most commonly used power tiller in Thailand in terms of heart rate of the operator and reported that the surface condition of the agricultural field was another factor contributing to operator workload. Tiwari and Gite (2000) evaluated the physiological cost of a 10.5 kW rotary type power tiller with and without seating attachment. Mean heart rate and oxygen consumption rates varied from 85.1 to 90.2 beats min^{-1} and 6.68 to 8.98 $kJ\ min^{-1}$, respectively, with the increase in forward speed from 1.04 to 4.14 $km\ h^{-1}$ with seating attachment. Without seating attachment the heart rate and oxygen consumption rate varied from 90.3 to 134 beats min^{-1} and 8.77 to 16.07 $kJ\ min^{-1}$, respectively.

Methods and Materials

Among different makes of power tillers popular among the farmers of the study region, two power tillers with one as walking type (7.46 kW) and the other as riding type (8.95 kW) were selected. The selected operations included rotary tilling in untilled and tilled fields and transport on farm and bitumen roads. The selected levels of forward speed of operation were 1.5, 1.8, 2.1, 2.4 $km\ h^{-1}$ and 3.5, 4.0, 4.5, 5.0 $km\ h^{-1}$ for field and transport operations, respectively. Three subjects were selected based on the age and weight and screened for normal health through medical investigations. The selected subjects were well acquainted with the controls of power tiller and had experience of operating power tillers under different terrain conditions. All the three subjects were calibrated in the laboratory condition by assessment of oxygen uptake in response to heart rate and their maximum aerobic capacity was computed. The physiological response was assessed through the measurement of heart

rate for field and transporting operations.

The power tiller was put in proper test condition before conducting the trials. It was in full working order with full fuel tank and radiator, without optional front weights and any specialized components. Tires used for the tests were of standard size and depth of treads was not less than 70 percent of depth of a new tread. The mean dry bulb temperature, wet bulb temperature and rela-

tive humidity varied between 25 to 32 °C, 18 to 25 °C and 25 to 76 percent respectively during the period of evaluation.

The experiment was conducted at different time intervals of the day between 8:30 AM and 5:00 PM as the effect of environmental condition causes changes in heart rate values of the subjects. To minimize the effects of variation in environmental and soil factors, the treatments were given in randomized

order. All the three subjects were equally trained in the operation of power tiller with rotavator. The subjects were given information about the experimental requirements so as to enlist their full cooperation. They were asked to report at the work site at 8:00 AM in post-absorptive stage and have a rest for 30 minutes before starting the trial. A rest period of 90 minutes was given between the three trials on the same day, with the same subject.

After 30 minutes of resting, the subject was asked to operate the power tiller (already started by another person and engine throttle position set at required engine speed and gearshift lever in the required position corresponding to the selected forward speed) for a duration of 15 minutes. The duration of measurement was fixed as 15 minutes in accordance with the physiological studies conducted by Tiwari and Gite, 1998 and Vidhu, 2001. The speedometer was monitored to be achieve a constant speed throughout the period of investigation.

a. Rototilling

The experiment was carried out in the field using a rotavator in both untilled and tilled conditions. The soil was sandy clay with 48.47 percent clay, 40.47 percent sand and 9.1 percent silt. The soil moisture and bulk density were 11 percent (d.w.) and 1.31 g cm⁻³ for untilled and 7 percent (d.w.) and 1.2 g cm⁻³ for tilled conditions. The surface condition of untilled field was dry and undulating with a weed intensity of 370 g m⁻². The surface condition of tilled field was dry with small undulations and without weeds. The recommended tire pressure (1.5 kg cm⁻²) was maintained for the wheels. Depth of operation was maintained at about 15 cm throughout the period of investigation. The trials were conducted at the selected four levels of forward speed with both the power tillers in untilled and tilled field. The heart rate was measured

Table 1 Energy cost of power tiller A and B during rototilling

Forward speed, km h ⁻¹	Power tiller	Operation	Energy cost, kJ min ⁻¹	Grading of work
1.5	Walking type (A)	Rototilling in untilled field	17.13	Moderate work
		Rototilling in tilled field	15.70	
	Riding type (B)	Rototilling in untilled field	13.95	
		Rototilling in tilled field	13.28	
1.8	Walking type (A)	Rototilling in untilled field	17.98	Moderate work
		Rototilling in tilled field	16.06	
	Riding type (B)	Rototilling in untilled field	14.49	
		Rototilling in tilled field	13.72	
2.1	Walking type (A)	Rototilling in untilled field	19.01	Moderate work
		Rototilling in tilled field	16.91	
	Riding type (B)	Rototilling in untilled field	14.99	
		Rototilling in tilled field	14.01	
2.4	Walking type (A)	Rototilling in untilled field	20.09	Moderate work
		Rototilling in tilled field	18.23	
	Riding type (B)	Rototilling in untilled field	15.43	
		Rototilling in tilled field	14.59	

Table 2 Energy cost of power tiller A and B during transport

Forward speed, km h ⁻¹	Power tiller	Operation	Energy cost, kJ min ⁻¹	Grading of work
3.5	Walking type (A)	Transport in farm road	10.50	Light work
		Transport in bitumen road	10.17	
	Riding type (B)	Transport in farm road	12.11	
		Transport in bitumen road	11.32	
4.0	Walking type (A)	Transport in farm road	10.89	Light work
		Transport in bitumen road	10.69	
	Riding type (B)	Transport in farm road	12.36	
		Transport in bitumen road	11.15	
4.5	Walking type (A)	Transport in farm road	10.83	Light work
		Transport in bitumen road	10.78	
	Riding type (B)	Transport in farm road	12.69	
		Transport in bitumen road	11.42	
5.0	Walking type (A)	Transport in farm road	11.05	Light work
		Transport in bitumen road	11.12	
	Riding type (B)	Transport in farm road	12.82	
		Transport in bitumen road	11.67	

and recorded using a computerized heart rate monitor for the entire work period. The same procedure was repeated three times for all the selected subjects. The view of the measurement of heart rate during the operation of power tiller B in untilled field is shown in Fig. 1.

b. Transporting

The tests were carried out on farm roads and bitumen roads on transport mode of power tiller attached with an empty trailer for both power tiller A and B at four levels of forward speed. The recommended tire pressure (2.5 kg cm⁻²) was maintained for the wheels. The heart rate of the subject was measured and recorded using computerized heart rate monitor for the entire work period. Measurements were taken for 15 minutes duration and repeated three times for each subject. A view of the measurement of heart rate during the operation of power tiller A with trailer attachment on a farm road is shown in Fig. 2.

The recorded heart rate values from the computerized heart rate monitor were downloaded to the computer through the interface provided for all the operations. From the down loaded data, the values of heart rate at the resting level and at the 6th to 15th minute of operation were taken for calculating the physi-

ological responses of the subjects. From the mean value of heart rate (HR) observed during the trials, the corresponding values of oxygen consumption rate (VO₂) of the subjects for the selected operations were predicted from the calibration chart of the subjects. The energy cost of operation was computed by multiplying the oxygen consumed by the subject with the calorific value of oxygen (20.88 kJ lit⁻¹) (Nag et al., 1980) for all the subjects. To ascertain whether the operation of the power tillers was within the acceptable workload (AWL), it was necessary to compute the VO₂ max for each subject.

Results and Discussion

i. Energy Cost of Operation

The physiological response of the subjects during rototilling with a walking type power tiller (A) and riding type power tiller (B) in untilled and tilled fields and grading of the work are furnished in Table 1.

Based on the mean energy expenditure, the operation was graded as “moderate work” for all the selected levels of forward speed (Rodahl, 1989). Comparison between untilled and tilled field operation showed a marked difference in the energy expenditure between the terrain condi-

tions (Fig. 3). The subjects expended more energy during rototilling in untilled field than tilled field operation. The increase in forward speed resulted in the increase of energy expenditure of 9.1 to 10.20 percent when compared to the tilled field. The higher energy cost involved in untilled terrain might be due to the additional effort required by the subjects in walking and guiding the power tiller in soil with stubbles of previous crops. In addition, the bite of tynes of the rotary tiller on the relatively compacted terrain of untilled soil induces vibration, which might have increased the energy cost of the subjects. Therefore, the surface condition of the agricultural field was another factor contributing to operator’s workload (Mamansari and Salokhe, 1999). The results clearly indicated that the energy expenditure of the subjects was influenced by the terrain conditions (Mc Ardle, 1994). Comparison between power tiller A and power tiller B clearly showed a marked difference in energy expenditure between the two power tillers as shown in Fig. 3. The mean energy expenditure of the subjects was higher for power tiller A than those for power tiller B in both untilled and tilled fields.

As power tiller B was provided with a seating attachment, the operator could comfortably sit and ride

Fig. 3 Energy cost of power tiller operations

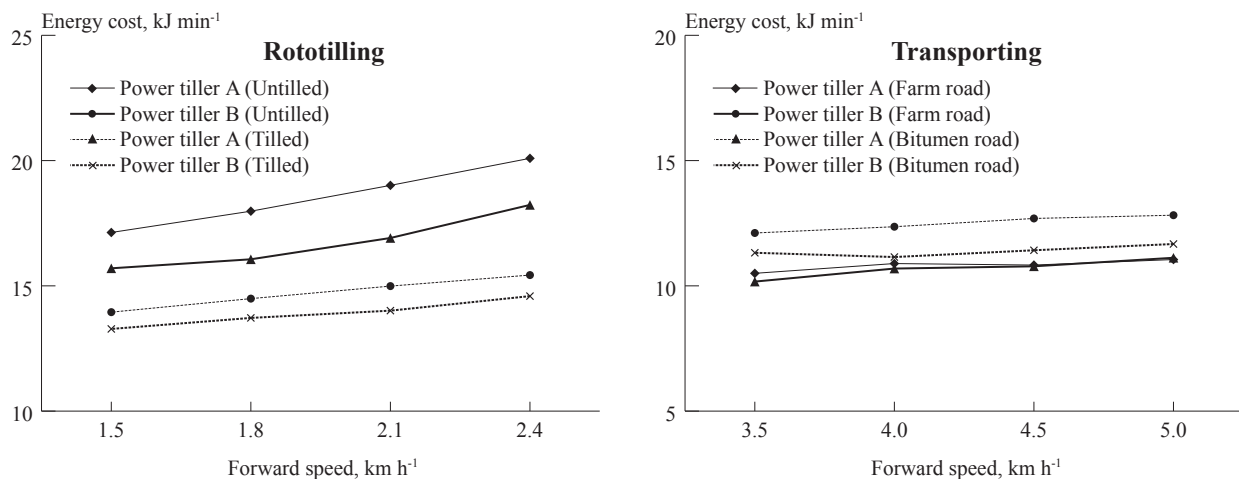

the power tiller with little drudgery. But, in the walking type power tiller (Power tiller A), the subjects must walk during the entire period of operation. It is observed that operating the power tiller with a seating attachment saved human energy requirement to the tune of 23 to 30 percent with increase in forward speed from 1.5 to 2.4 km h⁻¹ in untilled field and 18 to 25 percent in tilled field, respectively. The results clearly indicated that operation of power tiller without a seating attachment involved higher physiological cost in comparison to that with seating attachment. This confirmed the earlier results reported by Tiwari and Gite, 2000). The effect of terrain condition on energy cost of the subject was more pronounced in untilled field when compared to tilled field for both the power tillers.

The physiological response of the subjects during transport with walking type power tiller (A) and riding type power tiller (B) on farm roads and bitumen roads and grading of the work are furnished in **Table 2**.

Based on the mean energy expenditure, the operation was graded as "Light work" for all the selected levels of forward speed (Rodahl, 1989). The increase in energy cost was 17.27 percent as the forward speed increased from 1.5 to 2.4 km h⁻¹. Comparison of energy cost of work between farm road and bitumen road is shown in **Fig. 3**. The increase in energy expenditure was by

6.97 to 10.85 percent on farm road than bitumen road for the speed level from 3.5 to 5.0 km h⁻¹. This might be due to the more discomfort experienced by the subject while operating the power tiller on farm roads with undulations and surface roughness.

Comparison between power tillers A and B during transport with trailer showed that human energy requirement was higher for power tiller B when compared to power tiller A as depicted in **Fig. 3**. This might be due to the fact that maneuvering and handling of power tiller B was more difficult than power tiller A since the positioning of the handle and trailer seat with respect to engine was at a longer distance for power tiller B (1,850 and 2,270 mm) when compared to power tiller A (1,170 and 2,150 mm). Moreover the weight of power tiller B (517 kg) was more than power tiller A (442 kg). The subjects might have exerted more energy in handling the heavy weight power tiller B. It is observed that when compared to power tiller B, operating power tiller A with an empty trailer resulted in saving of human energy requirement to the tune of 15.33 to 16.23 percent on a farm road and 11.3 to 4.9 percent on a bitumen road with increase in forward speed from 3.5 to 5.0 km h⁻¹, respectively.

ii. Acceptable Workload (AWL)

The mean oxygen uptake of all

operating conditions in terms of maximum aerobic capacity was calculated for all the subjects and the values are furnished in **Table 3**. For field operation with the walking type power tiller the oxygen uptake in terms of VO₂ max varied from 35.30 to 43.93 percent which was above the acceptable work load whereas the values varied from 29.04 to 33.74 percent for riding type (8.95 kW) power tiller and was within the acceptable workload. During transport mode oxygen uptake in terms of VO₂ max varied from 22.24 to 28.03 percent and the values were within the acceptable limit of 35 percent of VO₂ max for both power tillers.

iii. Limit of Continuous Performance (LCP)

The increase in physiological responses over resting values of heart rate (Δ HR) for all the subjects at selected levels of forward speed for all selected operations were calculated and the values are furnished in **Table 4**.

It is observed that the work pulse (Δ HR) for all the operations at selected levels of forward speed varied from 21.08 to 37.79 percent during rototilling in untilled and tilled field respectively. It varied from 13.23 to 19.88 and 11.42 to 17.50 during transport operation on farm and bitumen road respectively. The work pulse values for power tiller B were lower than power tiller A both in untilled and tilled field. This confirmed the result that the seating arrangement provided in power tiller B enhanced the comfort of the subjects. It was observed that in all the selected operations, the work pulse values were well within the limit of continuous performance of 40 beats min⁻¹ for both power tillers on a farm and a bitumen road.

Conclusions

Based on the analysis of results the

Table 3 Oxygen uptake in terms of VO₂ max for power tiller operation

Operation	Power tiller	Maximum aerobic capacity of subjects, %				AWL, 35 % of VO ₂ max
		Forward speed, km h ⁻¹				
1. Rototilling		1.5	1.8	2.1	2.4	
Untilled field	A	37.45	39.32	41.57	43.93	> AWL
	B	30.50	31.68	32.78	33.74	< AWL
Tilled field	A	35.30	35.60	36.98	39.86	> AWL
	B	29.04	30.00	30.64	31.91	< AWL
2. Transport mode		3.5	4.0	4.5	5.0	
Farm road	A	22.96	23.81	25.43	26.44	< AWL
	B	26.48	27.03	27.75	28.03	< AWL
Bitumen road	A	22.24	24.09	24.16	25.65	< AWL
	B	24.75	24.38	24.97	25.52	< AWL

following conclusions were drawn.

- The basal metabolic rate of the selected three subjects varied from 1,402 to 2,005 kcal day⁻¹.
- The relationship between the heart rate and oxygen consumption of the subjects was found to be linear for all the subjects.
- The maximum aerobic capacity of the selected subjects varied from 1.98 to 2.48 L min⁻¹.
- For rototilling in untilled field the energy cost of work varied from 17.13 to 20.09 kJ min⁻¹ for walking type (7.46 kW) power tiller and 13.95 to 15.43 kJ min⁻¹ for riding type (8.95 kW) power tiller. In tilled field the values varied from 15.70 to 18.23 kJ min⁻¹ and 13.28 to 14.59 kJ min⁻¹, respectively. The operations were generally graded as “moderate work”.
- The rototilling operation in untilled field was strenuous as it demanded 9.1 to 10.20 percent and 1 to 6 percent more energy for walking type (7.46 kW) and riding type power tillers (8.95 kW), respectively, than in tilled field.
- Power tiller with seating attachment resulted in saving of 23 to 30 percent and 18 to 25 percent human energy requirement in untilled and tilled field, respectively.
- In transport mode the energy cost of work varied from 10.17 to 11.12 kJ min⁻¹ and 11.32 to 12.82 kJ min⁻¹ with the 7.46 kW and 8.95 kW power tillers, respectively. The operation was generally graded as “light work” to “moderate work”.
- When compared to 8.95 kW power tiller, the 7.46 kW power tiller resulted in a saving of human energy requirement of 15.33 to 16.23 percent on a farm road and 4.9 to 11.3 percent on a bitumen road. The energy cost increased with increase in forward speed of operation.
- For field operation with walking

type power tiller the oxygen uptake in terms of VO₂ max varied from 35.30 to 43.93 percent which was above the acceptable work load whereas the values varied from 29.04 to 33.74 percent for riding type (8.95 kW) power tiller and was within the acceptable workload.

- During transport mode oxygen uptake in terms of VO₂ max varied from 22.24 to 28.03 percent and the values were within the acceptable limit for both power tillers.
- The work pulse (Δ HR) varied from 21.08 to 37.79 percent for field operations and 11.42 to 19.88 for transporting operations and were within the limit of continuous performance.

REFERENCES

- Mamansari, D. U. and V. M. Salokhe. 1999. The need for ergonomics considerations for the design and development of agricultural machinery in Thailand. *Journal of human Ergology*, 24(1): 61-72.
- McArdle, D. E., F. I. Katch, and V. L. Katch. 1994. *Essentials of exercise physiology*. Lea & Febiger, A Waverly Company, Philadelphia. pp. 508.
- Mehta, C. R., P. S. Tiwari, and A. C. Varshney. 1997. Ride vibrations on a 7.5 kW power tiller. *J. agric. Engng Res.*, 66: 169-176.
- Pawar, J. G. 1978. Investigation of human energy requirements for power tiller operation. Unpublished M. Tech Thesis, Punjab Agricultural University, Ludhiana.
- Tiwari, P. S. and L. P. Gite. 2000. Physiological cost evaluation of a 10.5 kW rotary type power tiller with and without seating attachment. *Agricultural Engineering Today*, 24(6): 49-59.
- Tiwari, P. S. and L. P. Gite. 1998. Human energy expenditure during power tiller operations. Paper presented during XXXIII annual convention of ISAE, CIAE, Bhopal, Sept. pp. 21-23.
- Vidhu, K. P. 2001. An investigation on ergonomic evaluation of selected rice farming equipment. Unpublished M.E. (Ag.) Thesis, Department of Farm Machinery, Tamil Nadu Agricultural University, Coimbatore, India.

Table 4 Work pulse (Δ HR) for power tiller operation

Operation	Power tiller	Work pulse, beats min ⁻¹				LCP, 40 beats min ⁻¹
		Forward speed, km h ⁻¹				
1. Rototilling		1.5	1.8	2.1	2.4	
Untilled field	A	32.25	34.79	37.24	37.79	< LCP
	B	21.08	24.92	24.86	25.21	< LCP
Tilled field	A	27.47	28.24	31.23	33.16	< LCP
	B	22.02	22.28	23.09	24.88	< LCP
2. Transport mode		3.5	4.0	4.5	5.0	
Farm road	A	13.29	13.23	17.46	18.71	< LCP
	B	18.81	19.35	19.52	19.88	< LCP
Bitumen road	A	11.42	15.13	13.67	17.50	< LCP
	B	16.14	16.06	16.96	16.78	< LCP

Vibration Mapping of Walking and Riding Type Power Tillers

by



K. Kathirvel

Professor and Head
Agricultural Engineering College
and Research Institute,
Tamil Nadu Agricultural University,
Coimbatore - 641 003
INDIA

Binisam

Ph. D. Scholar
Agricultural Engineering College
and Research Institute,
Tamil Nadu Agricultural University,
Coimbatore - 641 003
INDIA



R. Manian

Dean
Agricultural Engineering College
and Research Institute,
Tamil Nadu Agricultural University,
Coimbatore - 641 003
INDIA

T. Senthikumar

Dean
Agricultural Engineering College
and Research Institute,
Tamil Nadu Agricultural University,
Coimbatore - 641 003
INDIA

Abstract

The major excitation of the vibration of the power tiller is the unbalanced inertia force of the engine. Further vibration exciting forces are the transmission system. The mechanical vibration is transmitted to the human body through the handle and seat. The magnitude of mechanical vibration at different components of the power tiller system is essential for identifying the source of vibration and providing vibration isolators to increase the safe exposure limit of operators. The mechanical vibration of walking and riding type power tillers was measured at different locations in stationery condition, during rototilling in untilled and tilled soil and in transport mode on bitumen and farm roads. Comparing the acceleration at the differ-

ent locations, the vibration at the top of the engine was highest followed by chassis, handle, root of handle bar and gear box for both walking and riding type power tillers. In stationary mode the increase in engine speed resulted in two fold increase in machine vibration at handle for both power tillers. Among the power tillers the vibration at handle was higher by 72.94 to 170 percent for the riding type power tiller. In field operation and transport mode the increase in forward speed of operation resulted in increased values of acceleration. The magnitude of vibration was higher at handle (40.50 percent) and seat (28.08 percent) in untilled field than tilled field. In transport mode farm road induced higher vibration than bitumen road. Among the power tillers the vibration induced in walking type power

tiller was higher during field operation whereas in transport mode power tiller (8.95 kW) exhibited higher values.

Introduction

The operator of a power tiller has to endure various environments and stresses. The environment includes all the factors in the surroundings which have an effect on man-machine system. Among these factors, mechanical vibration is more important because it significantly accelerates fatigue and affects sensitivity and reaction rates of the operator. Excessive noise level, vibrations and uncomfortable posture are the important shortcomings in power tiller design (Pawar, 1978). Mechanical vibrations have instantaneous and

long term effects upon the human body. Walking control and riding control type power tillers are in use at present. In walking control type, a random vibration is transmitted to the operator's chest through his hands (hand transmitted vibration). In case of a riding control type, two possible types of vibration are transmitted to the operator's body, one is through seat as whole body vibration (WBV) and other is through his hands as hand transmitted vibration (HTV). In this paper the mapping of mechanical vibration transmitted from the engine to the handle is reported.

Review of Literature

Vibration affects human performance. It is usually characterized by its frequency, acceleration and direction. It affects the whole body (Whole body vibration) and it affects parts of it, such as the hands (Hand transmitted vibration). Both whole body and local vibration can cause vibration throughout the body (Rodahl, 1989). Vibration is defined as oscillatory motion about a fixed point. A vibration is called periodic when the oscillation repeats itself. Vibrations primarily are of two types (Sanders and McCormick, 1993). In the first type of vibration, the body continues to vibrate at the same frequency over a considerable period of time. The simplest

way of describing this motion is by a sinusoidal equation. The other type of vibration is that of one-time shocks and impacts, called non periodic vibrations. Majumder (1994) reported that analysis of power tiller vibration in stationary condition was complex. Acceleration and frequency of vibration changed depending on engine speed and experimental conditions. These were increased with an increase in engine speed. The human body reacts to the different kinds of vibration in various ways. The human body is not rigid, and different body parts vibrate differently even if they are under the influence of the same linear vibration (Kroemer et al., 2000). Vibration seems to generate muscle reflexes, which have a protective function, causing the extended muscle to shorten. The reflex activity of the muscles also explains the often observed increase in energy consumption, heart rate and respiratory rate when a person is exposed to strong vibrations. These vibrational effects on metabolism, circulation and respiration are small and have little significance (Kroemer and Grandjean, 2000).

Methods and Materials

Machine vibration of different components in stationary mode as well as handle and seat vibrations under operating conditions in field

and on road were measured to know the magnitude of vibration transmitted to the subject.

Vibration Characteristics at Stationary Mode

The idea of measuring the vibrations of a power tiller in a stationary mode was to determine the vibration of the machine in free moving mode without any influence of the human operator. The major source of induced vibration is the engine and the vibrations are transmitted to the operator through the handle in the walking type power tiller (A) and through handle and seat in riding type power tiller (B), therefore the accelerometer was mounted on the engine top, chassis, transmission gear box, root of handle bar and handle for power tiller A and engine top, chassis, transmission gear box, root of handle bar, handle and seat for power tiller B as shown in Fig. 1. The machine vibration was measured using the ENDEVCO Istron model 751-10 accelerometer of the B & K instrument. Vibration signals in the vertical mode were recorded by employing Fast Fourier Transform (FFT) technique using the FFT analyzer built in the PULSE multi-analyzer system. FFT is a powerful analytical tool which transforms the random time domain data into highly descriptive frequency data. The trial was conducted for different engine speeds for both power tillers. Each trial was repeated for three

Fig. 1 Components showing measurement of machine vibration

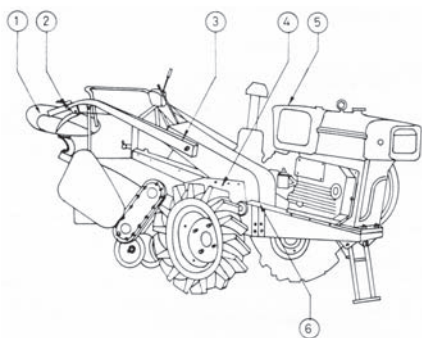

1. Seat, 2. Handle, 3. Root of the handle bar, 4. Transmission gear box, 5. Engine top, 6. Chassis

Fig. 2 Accelerometer on handle of power tiller A



Fig. 3 Accelerometer placed on metallic seat of power tiller B



times with an acquisition period of 30 sec and the peak value obtained from the spectrum was averaged for each engine speed. The views of the accelerometer placed on the handle of power tiller A and on the seat of power tiller B are shown in **Fig. 2** and **3**, respectively.

Vibration Characteristics in Rototilling Operation

The measurement of machine vibration during tillage was aimed to determine the vibration level of the power tiller with the influence of implement during field operations, as well as the effect of terrain in order to understand the amount of vibration transmitted to the body by comparing with the hand transmitted and whole body vibration. The measurements were taken in untilled and tilled fields using rotovator. The accelerometer was mounted on the root of handle bar and handle for the power tiller A and on the root of handle bar, handle and underneath the seat for power tiller B.

Vibration Characteristics in Transporting Operation

The vibration characteristics of the power tiller handle and seat are

different while riding a power tiller with an empty trailer. Therefore, vibration levels were measured on the root of handle bar, handle and underneath the seat for power tiller A and power tiller B during transport on farm roads and bitumen roads.

Results and Discussion

Vibration Characteristics at Stationary Mode

a. Power Tiller A

The peak acceleration values obtained from the vibration spectrum for power tiller A at different engine speeds are presented in **Table 1**.

As the engine speed increased, the peak acceleration also increased at different locations. Since the major vibration contribution was the power stroke of the engine, as the engine speed increased more power strokes are completed per second and the different components of power tiller vibrate frequently and resulted in higher values of acceleration. The increase in engine speed of power tiller A from 900 to 2,300 rpm resulted in two fold increase in vibration at engine top, nearly six fold increase at the chassis, four fold

increase at the gear box, three fold increase at the root of handle bar and two fold at the handle.

Comparing the acceleration at the different locations of power tiller A, it was found that the vibration at the top of the engine was highest followed by chassis, handle, root of handle bar and gear box. The vibration at the top of the engine was the highest since the major excitation of the vibration of the power tiller was the unbalanced inertia force of the engine (Jiao Qunying et al., 1989; Dong, 1996 and Ying et al., 1998). The vibration magnitude at the gear box was the lowest among other locations, since the free movement of the gear box was restricted by the pneumatic wheels supported on the ground which act as vibration damping medium. The handle of the power tiller showed higher acceleration than at root of handle bar because the handle of the power tiller was like a cantilever beam. It was subjected to forced as well as free vibrations. The longitudinal movement of the root of handle bar was restricted because the end of the handle was attached rigidly to the frame of the power tiller and hence showed lower magnitude of vibration compared to the handle.

b. Power Tiller B

The peak acceleration values obtained from the vibration spectrum for power tiller B at different engine speeds are shown in **Table 2**.

As in power tiller A, the acceleration values increased with engine speed at all locations (Majumder, 1994 and Mamansari, 1998). The increase in engine speed from 900 to 2,000 rpm resulted in three fold increase in vibration at the engine top, nearly four fold increase in the chassis, four fold increase at the gear box, four fold increase at the root of handle bar, two fold at the handle and one and half fold increase at the seat of the power tiller B. The highest value of acceleration was obtained at the top of the engine

Table 1 Machine vibration of power tiller A in stationary mode

Engine speed, rpm	Peak acceleration, ms ⁻²				
	Engine top	Chassis	Gear box	Root of handle bar	Handle
900	12.1	3.35	0.52	2.44	4.25
1200	14.0	4.74	0.62	2.65	5.25
1500	16.0	6.10	0.72	2.98	5.70
1800	18.2	11.60	1.12	3.07	6.13
2000	24.3	11.90	1.59	4.31	6.25
2300	25.8	20.90	2.03	7.42	9.14

Table 2 Machine vibration of power tiller B in stationary mode

Engine speed, rpm	Peak acceleration, ms ⁻²					
	Engine top	Chassis	Gear box	Root of handle bar	Handle	Seat
900	18.05	6.61	0.77	2.66	7.35	12.75
1200	19.20	14.45	0.85	5.24	10.95	15.55
1500	40.75	15.40	1.69	4.83	11.27	17.25
1800	53.25	25.65	2.24	8.45	13.20	18.35
2000	54.20	27.05	2.90	9.49	16.90	19.30

followed by chassis, seat, handle, root of handle bar and gear box as observed in power tiller A. The seat showed the highest value of acceleration, after the engine top, followed by chassis. This was due to the free vibrations in addition of forced vibrations since the seat was attached to the power tiller as a separate unit and whose vibrations change as per the mass. The increase in the engine speed from 900 to 2,000 rpm resulted in an increased peak value of acceleration by 130 percent for the handle and 51.37 percent for seat.

Comparing power tillers A and B, power tiller B showed highest values of acceleration at all locations measured at the same engine rpm as depicted in Fig. 4. The increase in peak value of acceleration for the power tiller B was 49.17 percent to 123 percent at the engine top, 97.3

to 127 percent at the chassis, 47.78 to 82.70 percent at the gear box, 9.01 to 120 percent at the root of the handle bar, 72.94 to 170 percent at the handle with the increase in engine speed from 900 to 2,000 rpm when compared to the power tiller A. This might have been due to the higher rated horsepower produced by the engine of the power tiller B (8.95 kW) compared to power tiller A (7.46 kW). In addition, the positioning of the handle and seat with respect to the engine was at a greater distance (1,850 and 2,270 mm) for power tiller B as compared to the power tiller A (1,170 and 2,150 mm). Since the handle and seat of power tiller B was positioned further from the engine compared to power tiller A, these parts were subjected to more free vibrations.

Vibration Characteristics in Rototilling Operation

a. Power Tiller A

The highest value of acceleration obtained from the vibration spectrum for power tiller A at selected forward speeds in untilled and tilled fields are shown in Table 3. It was observed that the magnitude of acceleration on the root of the handle bar and handle increased with increase in selected levels of forward speed in both untilled and tilled field. A two fold increase in peak acceleration on the handle was recorded with increase in forward speed from 1.5 to 2.4 km h⁻¹ in untilled fields. Similarly, in tilled fields the increase in acceleration was 53.96 percent as the forward speed increased from 1.5 to 2.4 km h⁻¹.

The peak acceleration on the handle was higher in untilled filed

Fig. 4 Machine vibration of power tiller A and B in stationary mode

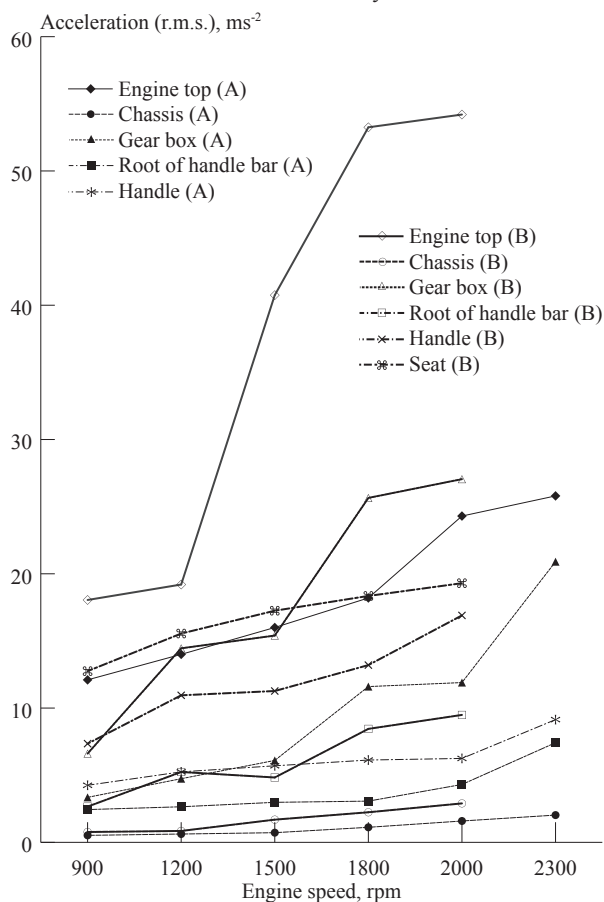
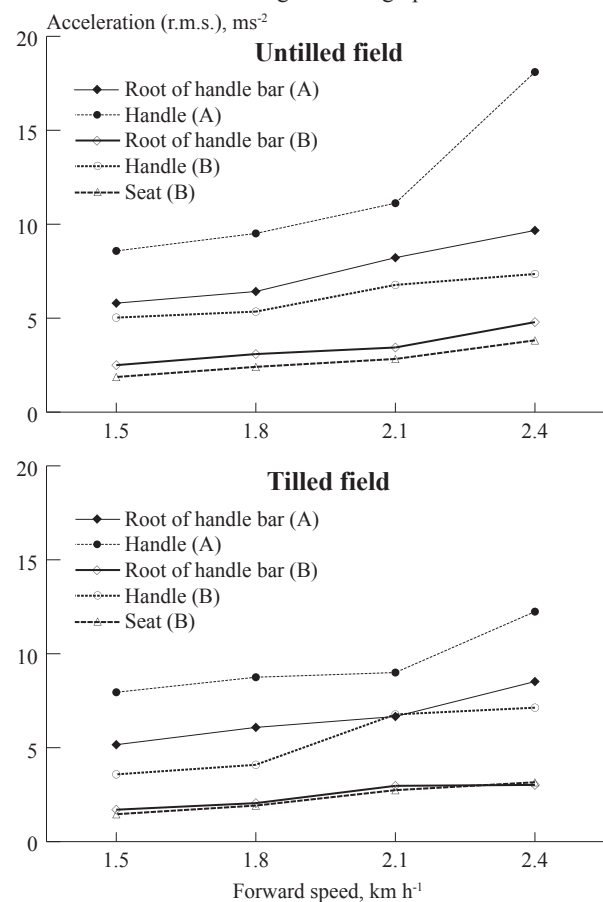

Fig. 5 Machine vibration of power tiller A and B during rototilling operation



than tilled field. The percentage increase in peak acceleration in untilled fields, when compared to tilled fields, was 12.51 to 13.50 percent at the root of handle bar and 7.86 to 47.74 percent at the handle with the increase in forward speed from 1.5 to 2.4 km h⁻¹. This indicated the effect of terrain induced vibration through wheels (Clijmans et al., 1998). Since the untilled field was dry, rough and compact compared to tilled field, damping effect was less in untilled fields. Also, the presence of root stalks of previous crops and biting of tines on hard soil

might add vibration to the system. Hence, the magnitude of vibration was higher in untilled fields compared to tilled fields.

b. Power Tiller B

The peak value of acceleration obtained from the vibration spectrum for power tiller B at selected forward speeds in untilled and tilled fields is shown in **Table 4**.

Increase in forward speed from 1.5 to 2.4 km h⁻¹ resulted in an increased peak value of acceleration by 91.6 percent at the root of handle bar, 46.12 percent at the handle and

104 percent at the seat in untilled fields. Similar results are observed in tilled fields in which the increase in magnitude of acceleration varied from 77.6 percent at root of handle bar, 99.16 percent at handle and 116 percent at seat as the forward speed increased from 1.5 to 2.4 km h⁻¹. The peak acceleration on the handle and underneath the seat was higher in untilled fields (**Fig. 4**) than in tilled fields as observed in power tiller A (Clijmans et al., 1998).

Comparison between handle vibrations of power tillers A and B during rototilling showed that acceleration values were higher for power tiller A than power tiller B both in untilled and tilled as depicted in **Fig. 5**. This might be due to the fact that power tiller B was a riding type power tiller and the seat was rigidly attached to the power tiller with a rear wheel below the seat. Since the vibration was measured during the actual field condition, the total weight of the power tiller B (581 kg) was higher than that of power tiller A (442 kg) since it included the weight of the subject also. This provided additional damping to the system and hence resulted in lower values of acceleration for power tiller B.

Vibration Characteristics in Transporting Operation

a. Power Tiller A

The peak value of acceleration obtained from the vibration spectrum for power tiller A at selected forward speeds on farm roads and bitumen roads are shown in **Table 5**. As observed in rototilling, increase in forward speed of the power tiller resulted in increased peak acceleration on the root of the handle bar, handle and underneath the seat. The increase in peak acceleration at handle was 29.82 percent and underneath the seat was 90.07 percent with the increase in forward speed from 3.5 to 5.0 km h⁻¹ during transporting on farm roads.

As observed in rototilling, in-

Table 3 Machine vibration of power tiller A during rototilling

Forward speed, km h ⁻¹	Peak acceleration, ms ⁻²			
	Untilled field		Tilled field	
	Root of handle bar	Handle	Root of handle bar	Handle
1.5	5.80	8.58	5.16	7.95
1.8	6.42	9.51	6.08	8.75
2.1	8.22	11.12	6.66	9.00
2.4	9.67	18.10	8.52	12.24

Table 4 Machine vibration of power tiller B during rototilling

Forward speed, km h ⁻¹	Peak acceleration, ms ⁻²					
	Untilled field			Tilled field		
	Root of handle bar	Handle	Seat	Root of handle bar	Handle	Seat
1.5	2.50	5.03	1.87	1.70	3.58	1.46
1.8	3.09	5.35	2.41	2.05	4.09	1.92
2.1	3.44	6.77	2.83	2.97	6.77	2.74
2.4	4.79	7.35	3.82	3.02	7.13	3.16

Table 5 Machine vibration of power tiller A with trailer on transport mode

Forward speed, km h ⁻¹	Peak acceleration, ms ⁻²					
	Farm road			Bitumen road		
	Root of handle bar	Handle	Seat	Root of handle bar	Handle	Seat
3.5	3.89	4.34	1.31	3.70	3.34	0.941
4.0	4.53	5.08	1.32	4.31	4.86	0.997
4.5	4.91	6.44	1.40	4.65	5.30	1.260
5.0	5.05	6.63	2.49	4.70	5.32	1.380

Table 6 Machine vibration of power tiller B with trailer on transport mode

Forward speed, km h ⁻¹	Peak acceleration, ms ⁻²					
	Farm road			Bitumen road		
	Root of handle bar	Handle	Seat	Root of handle bar	Handle	Seat
3.5	4.50	9.62	1.95	4.19	9.31	1.19
4.0	5.16	10.80	2.27	4.70	9.39	1.30
4.5	5.33	12.40	2.65	5.29	9.84	1.86
5.0	5.68	13.10	2.88	5.36	9.99	2.17

crease in forward speed of the power tiller resulted in increased peak acceleration on the root of the handle bar, handle and underneath the seat. The increase in peak acceleration at the handle was 29.82 percent and underneath the seat was 90.07 percent with the increase in forward speed from 3.5 to 5.0 km h⁻¹ during transporting on farm road. Similar results were observed on bitumen roads in which the increase in forward speed from 3.5 to 5.0 km h⁻¹ resulted in an increased peak value of r.m.s acceleration by 59.28 percent at the handle and 46.65 percent underneath the seat. The peak acceleration on the handle and underneath the seat was higher on farm roads than in bitumen roads (tar road). This clearly revealed the effect of terrain in inducing vibration. The reason for higher magnitude of vibration on farm roads was the unevenness and small undulations of farm road compared to relatively medium surface finish level on bitumen roads.

b. Power Tiller B

The peak value of acceleration obtained from the vibration spectrum for power tiller B at selected forward speeds on farm roads and bitumen roads are shown in **Table 6**.

The results were similar to the earlier findings that the magnitude

of vibration increased with forward speed. The values of acceleration on the handle and underneath the seat were increased by 36.17 and 47.69 percent, respectively with the increase in forward speed from 3.5 to 5.0 km h⁻¹ on farm roads. On bitumen roads, the peak acceleration on the handle and underneath the seat was increased by 7.3 and 82.35 percent with the increase in forward speed from 3.5 to 5.0 km h⁻¹, respectively. Comparison between power tillers A and B showed that magnitude of vibration was higher for power tiller B than power tiller A during transport with an empty trailer as depicted in **Fig. 6**. The percentage increase in power tiller B was 15.68 to 12.47 percent at root of the handle bar, 121.65 to 97.58 percent at the handle, 48.85 to 15.66 percent at seat on farm roads and 13.24 to 14.04 percent at root of the handle bar, 178.74 to 87.78 percent at the handle, 26.46 to 57.25 percent at seat on bitumen roads with the increase in forward speed from 3.5 to 5.0 km h⁻¹. This might be due to the fact that same trailer was attached to both power tillers and hence the weight of the trailer added same vertical load to the both power tillers unlike in field operations where the total weight of the power tiller B was increased due to the seated person when compared to power tiller A. In addition, the damping

effect of the terrain during transport was relatively less when compared to the field operations in which the soil mass acted as a cushion. So the same condition as that of stationary was obtained where the machine vibration of each location of power tiller B was higher than power tiller A, which was mainly due to higher rated horsepower of the engine.

Conclusions

Based on the analysis of the results the following conclusions are drawn

- In the stationary mode the increase in engine speed from 900 to 2,300 rpm resulted in two fold increase in vibration at engine top, nearly six fold increase at the chassis, four fold increase at the gear box, three fold increase at the root of handle bar and two fold at the handle of the walking type power tiller (A).
- The increase in engine speed from 900 to 2000 rpm resulted in three fold increase in vibration at engine top, nearly four fold increase in the chassis, four fold increase at the gear box, four fold increase at the root of handle bar, two fold at the handle and one and half fold increase at the seat of riding type

Fig. 6 Machine vibration of power tillers A and B transport mode

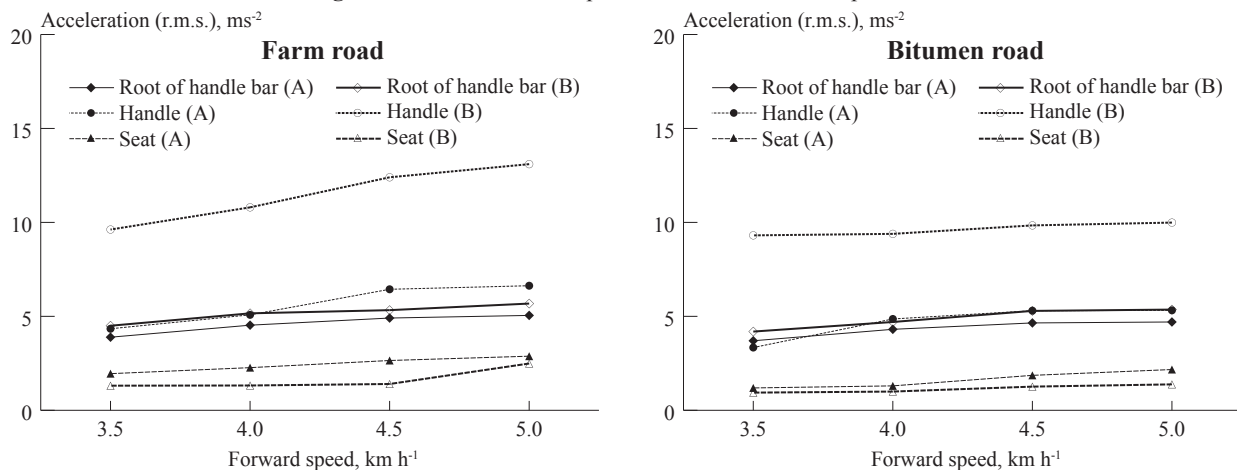

power tiller (B).

- Among the power tillers the vibration at the handle was higher by 72.94 to 170 percent for riding type power tillers.
- In field operation and transport mode the increase in forward speed of operation resulted in increased values of acceleration.
- The magnitude of vibration was higher at the handle (40.50 percent) and seat (28.08 percent) in untilled fields than tilled fields.
- In transport mode farm road induced higher vibration than bitumen road.
- Among the power tillers the vibration induced in walking type power tiller was higher during field operation whereas in transport mode power tiller (8.95 kW) exhibited higher values.

REFERENCES

- Dong, M. D. 1996. Testing analysis and evaluation of vibration transmitted by handles of GN-5 walking tractor. *Journal of Zhejiang Agricultural University*, 22(1): 68-72.
- Jiao Qunying., Dai Shiliang, and Ji Chunliang. 1989. The dynamic characteristics of a walking tractor. *Transactions of the Chinese Society of Agricultural-Machinery*, 20(4): 3-8.
- Guignard, J. C. 1985. *A text book of Industrial Hygiene and Toxicology, Biological Responses*, 2nd Edn, Wiley, New York, Chapter 15, Vibration: 653-724.
- Hornick, R. J. 1961. Effects of tractor vibration on operators. *Agricultural Engineering*, 42(12): 674-675 & 696-697.
- Kroemer, K. H. E., H. J. Kroemer, and K. E. E. Kroemer. 1997. *Engineering physiology* 3rd Edn., Van Nostrand Reinhold, A division of International Thomson Publishing Inc. New York: 209-215.
- Kroemer, K. H. E. and E. Grandjean. 2000. Fitting the task to the human. *A textbook of occupational ergonomics*. 5th Edn., Taylor & Francis Ltd., UK. pp. 118.
- Kroemer, K. H. E., H. B. Kroemer, and K. E. E. Kroemer. 2000. *Ergonomics-How to design for ease and efficiency*. Prentice-Hall Inc. Upper saddle River, New Jersey. pp. 112.
- Majumder, B. 1994. Vibration and noise characteristics of a Thai-made power tiller Unpublished M.E. Thesis. Asian Institute of Technology, Bangkok.
- Mamansari, D. U. 1998. Ergonomic evaluation of a commonly used power tiller in Thailand. Unpublished Ph.D. Thesis. Asian Institute of Technology, Bangkok.
- Pawar, J. G. 1978. Investigation of human energy requirements for power tiller operation. Unpublished M.Tech Thesis, Punjab Agricultural University, Ludhiana.
- Rodahl, K. 1989. *The physiology of work*. Taylor & Francis Ltd., London: 51-79.
- Seidel, H., R. Bastek., D. Brauer., C. H. Buchholz., A. Meister., A. M. Metz, and R. Rothe. 1980. On human response to prolonged repeated whole body vibration. *Ergonomics*, 23(30): 191-211.
- Ying, Y., L. Zhang., F. Xu, and M. Dong. 1998. Vibratory characteristics and hand-transmitted vibration reduction of walking tractor. *Transactions of the ASAE*, 41(4): 917-922.



Oman Traditional Farms: Changes and Improvement of Farms in Oman

by
Ahmed Al-Marshudi
Professor
Department of Agricultural Economics
and Rural Studies, College of Agriculture,
Sultan Qaboos University
P.O. Box 34 Al-Khod 123
Sultanate of OMAN
marshudi@squ.edu.om

Abstract

Traditional methods were developed to allow farmers to live in harmony with a harsh environment. The farming techniques employed required only limited inputs of capital and caused minimal disturbance to the environment. The patterns of production were truly sustainable and skills were passed from generation to generation. However, human development and population growth have led into significant change in the traditional farming. Thus, it is very often stated that success in any society could be measured by the balance required to manage and adjust traditional methods and cultural belief and modernization.

This paper examines the two types of farming systems in Oman, with more emphasis on water resources. In fact, most of the discussion is based on the two main classifications of farms. The analysis of the observed data found some of the economic and social problems which confront farmers at present in the northern part of the country. A number of recommendations have been suggested to tackle some of these problems. However, attempts

to undertake these actions require careful consideration of prevailing social rules and habits. It is well recognized that any suggested changes of an existing system may bring problems of greater complexity.

Introduction

Agriculture has existed in the Sultanate of Oman for thousands of years, as shown by the existence of the surface irrigation system referred as Aflaj (singular called falaj). Sutton (1984) stated "the ganat of falaj systems of Oman have provided communities with water for irrigation and domestic purposes for 1500-2000 years". In fact, the original establishment of the system goes back to about 7000 BC (Wilkinson, 1977).

In the early 1970's, the social and economic situation in the country changed. The major reason for the change was that oil was discovered creating movement toward modernization. The first two five-year development plans that were adopted in the country relied on the oil revenues. These two plans created tremendous progress, especially in

social infrastructure development (education, health, etc.) However, for the third five-year development plan (1986-1990) following the decline in oil prices, the government realized the importance of diversifying its national income. Therefore, the agricultural sector became a targeted sector to play a major role in diversifying the country's economy.

However, since ancient times, Omanis have relied on agriculture for their livelihood. In spite of the fact that oil discovery reduced the importance of agriculture as the main source of income, nearly half of the population is engaged in agriculture activities.

This paper examines some of the present economic and social problems that confront farmers at present in the northern part of the country. The nature of farming around the northern region of the country and some of the socio-economic relationships, which link the urban and rural populations, are discussed based upon data from fieldwork conducted between 1993 to 1999. The discussion is divided into three main sections: the nature environment within which agriculture in the region is practiced, the social

organization of this population and a preliminary analysis of recent socio-economic changes in these village communities.

With increasing evidence of change from the communal water management of falaj villages to individual agricultural holdings based upon wells, attention is drawn to the danger for farming of the misuse of nature resources. Change rates are being accelerated by factors both external and internal to village settlements. These include alterations to local power structures, economic diversification and cash circulation, and increasingly widespread labor migrations.

Three objectives are proposed here: to record the physical and natural environment within which farming is practiced in the area, to describe the social organization of the settlements involved in this activity, and to offer a preliminary analysis of recent patterns of socio-economic change in these communities. The objectives cover the issues of what is thought of as farming activities, where, how and when are they undertaken, and by whom. Some consideration is given also to agricultural support available locally, as well as major problems facing farmers.

Methodology

The study used primary as well as secondary sources of information. Secondary data were mainly from statistical reporting services of Ministry of Agriculture and fisheries and Ministry of National Economy. Primary sources on the organization and current structure used the author's own observations that were collected through random field observation throughout Oman. The visits were conducted through Sultan Qaboos University, College of Agriculture, student course visits. The preliminary stage was initiated in 1993 when in each semester the

author has to arrange a student visits to one of the agricultural extension centers nearby. Thus, both the students and the supervisors during the explanation in the field have asked questions. Sometime a group of farmers come together in order that students will see in practice how extension agents convey information to the farmers.

Information gathering for the agricultural extension program in Oman is essential for several reasons. First, to update the decision-maker, farmers and others concerned about problems that exists and the required solution. Second, to document information about farming and farmers' perceptions of agriculture in Oman. Third, to learn how the communication of various positions takes place among all those concerned in the agriculture system in Oman.

Therefore, this study used three main techniques in order to gather such information. First is the visit to the extension centers at different regions of the country to find out their activities with farmer. Second, is to meet with farmers so that communication of extension agents with farmers can be observed. Third, to visit the Ministry headquarters to understand how senior staff concerned with the extension service assist extension centers in the region and farmers.

Agricultural Development and Practice

The northern part of Oman, par-

Fig. 1 Traditional farm in Oman



ticularly the Batinal coastal strip, has been cultivated for at least as far back as the Sassanid period (Wilkinson, 1977). Stanger (1984) stated that "during the Persian influence between the mid-third and mid-seventh centuries AD. Remains are still seen of ancient cement lined falajis that transported water across the Batinah coastal settlements. Agriculture has existed in the Sultanate of Oman for thousands of years, as shown by the existence of the "Aflaj" irrigation system. Thus, Sutton (1984) stated that the ganate of falaj systems of Oman have provided communities with water for irrigation and domestic purposes for 1500-2000 years.

Oman over the last two decades have experienced a continuous development almost in all aspects of life. The revenues from the exploitation of oil have been reinvested in the development of the country and its people. The changes this has brought have affected every aspect of national life. Many parts of the traditional systems of agriculture and fisheries have benefited.

Traditional methods or systems can be defined as ways or techniques developed in the past to allow farmers and fishermen to live in harmony with harsh environment. (COA, 1995). In the recent past, the

Fig. 2 Traditional Palm-tree garden irrigated by aflaj system



nutrition of Omani's people rested almost completely upon what was produced by the land and the sea. Much has changed but the importance of those two elements has remained and will continue. Agriculture, the growing of crops, including tree crops, and the raising of livestock to provide food and fiber, has been practiced for over 1000 years (Fig. 1).

Agriculture in Oman is, and will continue to be a very important part of the economy. In the past, agriculture was traditional in nature; most people lived in small farming villages. The farmer and his family provided all the labor required for the production of crops, including tree crops and raising livestock. The farm unit functioned primarily to provide for the basic food needs of the family. Any surplus was sold or bartered to obtain necessities that the farm unit could not produce. Whenever possible a member of the farm family would seek some type of employment elsewhere to generate additional income for the family. As outside opportunities expanded, the general welfare of the family improved.

Farming activities then may be classified as belonging to one of two possible types: falaj irrigated farms, or well irrigated new farms. Generally speaking, the former primarily produces dates, and the latter livestock fodder in the form of alfalfa and new grown Rhod grass and vegetables like tomato, onion, cucumber and potatoes. However, as water provides the key to agriculture in Oman than elsewhere in the world, it is important to examine the implication of each system in more detail (Fig. 2).

Aflaj Irrigated Farms

Oman is almost exclusively dependent on rainfall for its supply of fresh water. Sub-surface and deep wells are the main sources of

water. Traditional surface irrigation systems of aflaj provide 38 percent of the fresh water supply in the Sultanate of Oman and irrigate around 55 percent of the cropped area (MRMEW, 2002). Over the years, these systems have set traditions for inter-temporal water resources allocation and a process of users rights established on ownership and/or rent basis. A management structure has been generated to organize, maintain and distribute aflaj water resources.

Several studies on hydrology and water resources of Oman have been carried out over the last decade. A number of studies for example, Wilkenson (1977); Norman (1997); Omezzine (1996); Marshudi (2000), focused on the Aflaj system. Others like Hayder (1993) search ways to conserve water in Oman. Zaibet (1996) and Omezzine (1997) attempted to find more efficient crops or high valued crops which consume water efficiently.

To sum up, falaj irrigation systems support relatively large numbers of people, on a fixed area of land, based upon a complex system of water supply and allocation from a source or sources, often, some distance from the settlement. To understand the structural organization and management of falaj system, the following aspects can be briefly summarized as follows:

1. Physical Structure: A falaj consists of a tunnel to tap groundwater and bring it to the surface

for distribution to crops and housing. It is designed to transport groundwater to the surface without any mechanical device or costly expenditure of fuel. This is achieved by excavating a tunnel (typically several kilometers long), which taps concentrated lines of groundwater flow and leads water to the surface along a channel at a lesser gradient than either the ground surface or the water table. Falaj systems have been running for centuries with high efficiency of water delivery. Water flow depends on hydraulic gradient along the tunnel starting from the mother well for tens of kilometers long. At the end of the tunnel, water is divided into lateral tunnels and then into small channels that supply individual garden (Fig. 3). The distribution channels and hydraulic structures need constant attention to control leakage and to distribute water to each lot. Points for the collection of drinking water and those set aside for washing also require maintenance.

2. Administrative Organization: Water ownership and distribution are governed through well-accepted social rules. These rules have generated an adapted management system that involves various responsibilities and functions undertaken by what is called the "the falaj

Fig. 3 Cross-section of qanat (falaj) in the piedmont zone



Source: Hayder and Omezzine, 1996

management committee". The administrative structure can be divided into two groups according to the work done. The first group can be considered as the administered superstructure. The second group consists of labors responsible for the physical implementation of the tasks.

3. Type of Falaj: Al-Rawas et al. (1999) have divided aflaj in Oman into two types, while Al-Ghafri (2000) and Hatmi (2000) divided aflaj into three types. The later stated that "Aflaj in Oman can be classified into three types depending on its source of water; ghainy, dawoodi and any". However, Al-Rawas regarded the any falj as part of the dawoodi . He stated that "when the source of a dawoodi falaj is a spring (single source), the falaj is known as an ayni falaj". The source of Dawoodi falaj is from underground acquifer, while the source of ghayli falaj is normally a surface aquifer in a wadi (Al-Rawas, 1999). Eighty percent of the aflaj in Oman are of Dawoodi type.
4. Crop Cultivation: Falaj crop cultivation is based upon a three-crop system with the date palm as the main crop. It has been indicated by the last agriculture census (MAF, 1993) that date palm provide approximately 80 percent of the cultivation with a scattering of citrus (mainly lime). However, in recent years, areas under lime cultivation and lime yield have drastically decreased to less than 40 percent of 1991 data. Indeed, majority of dense orchards in Batinah region have been either killed or removed as a direct result of a prokaryotic plant disease. The disease is named as witches' broom disease of lime. In addition, banana and mango are grown as inter-cropped among the palms. Apart from tree crops bull and swon with beans, sor-

ghum or Rhodes or other grass as livestock fodder are often grown under the palms.

Well Irrigated Farms

Stanger (1985) described that water well supply was learned by trail and error, eventually resulting in a narrow strip of cultivation, normally up to 3 km but occasionally up to 5 km from the sea. Costra (1987) showed the location of wells in Oman. He stated, "Wells provide water for settlements and fields in both the mountain zone and the Batinah, but it is only in the latter area they form the primary water source, and therefore partly determine the basic pattern of the irrigation and field system".

Originally, nearly all wells were of the animal powered driven type. In this old method animals such as bullocks or donkeys, yoked by rope to rubber or leather buckets, bailed water by walking up and down an excavated ramp. Obviously, this method is slow and inefficient and thus requires a constant supervision. Stanger (1985) showed the rate of irrigation that can be provided using old well animal driven power. He stated, "From observation of the few remaining animal-bailed wells of interior Oman it is estimated that a single zagira can irrigate about 0.8 ha of date or citrus trees or 1.5 ha of annual crops".

Change began well before Omans' oil boom. Stanger (1985) pointed out that the first diesel pumps were

installed before the 1950's but resistance to technical innovation, import restriction, and the lack of capital and commercial infrastructure, inhibited a widespread adoption of pumped irrigation. On the other hand, Costra (1987) stated that many traditional systems of water supply remain in use today, but others, such as the animal powered well, have witnessed a rapid decline since the 1950's.

According to the recent well inventory carried out in 1992 by the Ministry of Water Resources, there were 176,000 wells owned by citizens, of which 50 percent were concentrated in the Batinah region. In addition, the FAO Review report (1997) pointed out that 47 percent of the total number of 62,411 households, the well system is their main source of water.

A number of characteristics of well irrigated farms in Oman distinguish them from flaj irrigated farms. These can be summerized as follows:

1. This system uses modern methods of extracting underground sources of water. Diesel and electrical pumps have replaced animal power as a means of raising water from wells since 1960. Water is discharged into a reservoir or cistern of lined cement block construction.
2. Well irrigated farms are operated mainly for the production of the livestock fodder, invariably alfalfa. Vegetables and some fruit trees also grown in an open area using new irrigation

Table 1 Distribution of aflaj and wells irrigated farm all over the country

Region	Percentage of farms from total holding	Number of Aflaj	Number of Wells
Muscut	3.85	1,266	1,733
Batinah	33.59	6,572	16,409
Musandam	2.51	130	1,314
Dhahira	9.30	3,101	3,236
Interior	12.37	4,166	2,224
Sharqiya	19.68	8,652	1,746
Al-Wusta	2.07	0	5
Dhifar	16.63	27	946

methods in some farms such as droplet and spinkler irrigation method.

According to Agriculture census of 1993/94, wells in Oman provide the source of irrigation water for 46.8 percent of holdings with land compared to 38 percent for aflaj. For the balance of holdings, irrigation water was derived from other sources. The data in **Table 1** are reproduced from the Agriculture Census to illustrate the number of farms using the flaj system (date production on one hand) and wells (new farms used to cultivate animal folder and vegetables).

As mentioned earlier, Batinah region is characterized as having well irrigated farms, while Sharqiya followed by the Interior have the majority of farms that are irrigated from the old system (Falaj).

Traditional Omani society was farming on the subsistence pattern. The popular crops have been dates, lime, onion, garlic, wheat, alfalfa, watermelon and cucumber. The production of these crops was sustainable but low in productivity. Modern farming emerged after the discovery of oil in Oman. Heavy machines, new seeds, fertilizer, pesticides, more water resources, better management and marketing system resulted in a huge surge in agriculture production. There was a sharp increase in fruits, vegetables and field crops from 1978 to 1994. The area under fruit cultivation has increased from 35,885 ha in 1988/89 to 42,978 ha in 1993/94 at an increase of 16 percent. Nevertheless, present production of agricultural commodities in Oman is not sufficient to meet the local market demand. While Oman has considerable export of agricultural produce, the imports are nearly 10 times higher than exports.

Problems and Recommendation

A number of problems have been

identified in the falaj system. They fall into two categories. Problems due to physical structures of the falaj system and problems that have resulted from the administrative management of the system.

The physical structure problems can be summarized as follows:

1. Water conveyance of some aflaj over a wide gravel or earth bed has resulted in losses due to seepage and evaporation.
2. Water losses could be also attributed to breakage, poor grading of channels, and disorderly patterns of distribution.
3. The present structure of water right fragmentation has increased in channel losses.
4. The nature of the cycle (watering), which can go as long as 16 days, does not allow cultivation of high vegetable value crops and could lead to water stress during the dry hot days.

Problems, which result from social management focus on the socially accepted competitive conditions, are not solved when water rights are in the hands of a few large owners selling to many small waterless landlords. In addition, there is evidence of some market power leading to speculation and, therefore, to unacceptable higher water costs for small landowners.

To sum up, low demand, lack of free inter-community mobility and absence of new water collection and distribution system too often result in over-irrigation and waste of water during wet years and in regions with surplus water supply.

Agrarian reform of the aflaj system in Oman is, therefore, of great importance. A number of recommendations have been forwarded by Hayder and Omezzine (1996). A summery of these is as follows:

1. Improvement of the operation of the water tradable system through some form of public regulation.
2. Sustainable use of falaj water can be made more flexible by

the introduction of new engineering and irrigation techniques such as consolidated farming and the construction of artificial pools to collect and use water more efficiently to meet the needs of more diversified cropping systems.

3. Specific actions for aflaj water sustainability which may include:
 - i. Increasing efficiency of the present aflaj irrigation to combine the best features of the aflaj systems with the benefits of modern irrigation systems. Cultivation of high value crops to give an incentive to farmers to maintain their aflaj.
 - ii. Aflaj maintenance through channel lining and provision of improved dams and cisterns.
 - iii. More rational water distribution and modification of water rotation to suit crop requirement.

Installing water measuring devices and basing shares on time and discharge.

In recent years, the introduction of modern techniques, electric or diesel pumps, extracting water from these wells, have led to higher extraction rate compared with traditional methods. Another cause is the increase in agricultural productivity. As a result of this the following problems occur: At present groundwater depletion already takes place, especially in the coastal areas, leading to seawater intrusion and deterioration in water quality. The assessment of seawater interaction on the Batinah coast has been examined through several studies. The most important of these so far is the production of the series of maps comparing the extent of saline water interaction and falls in groundwater levels during the period 1983 to 1991 (Ministry of Water Resources, 1997).

Conclusion

This review of farming in the area of the northern part of Oman has focused upon the old irrigated falaj farms and the small new farms. Discussion has included the physical and natural environment within which farming operates; and the social organization of those activities. Below we try to summarize this account and examine in more details major areas of change.

Agriculture in the region presently includes two types: falaj, and new (well-irrigated) farms. The date gardens of the falaj are old-established agricultural systems designed to adapt crop husbandry to the arid environment. More recently new farms have been established outside old system where land area is fixed according to the irrigation abilities of the falaj. These individual holdings are irrigated by water and based upon a very much less labor-intensive system than that on which the falaj depends in its present form. Generally speaking a number of negative side effects of the newly established farm have been observed. These can be summarized as follows:

1. Establishment of many new wells has disrupted the quality of the groundwater.
2. Essential reciprocal behavior in economic and social relations between individuals in the falaj community, or between them and the nomadic population are altering.
3. Under present conditions managing a farm in the old aflaj irrigated farm and that in a new well irrigated farm may favor the later.

Factors both external and internal to the falaj community settlement appear to be accelerating the rates of change. The external factors included first, the removal of power from the interior to the coast, effectively from the local to the national center of Oman. Second, economic diver-

sification resulting locally in access to wider markets and the wider circulation of cash. Third, widespread labor migrations seeking high salary. Internally, the village demographic structure, upon which the upkeep of the falaj, the local division of labor and the successful flow of farming year depend, has been disrupted by rapid out-migration.

The overall picture drawn from reviewing of farming systems in Oman reveals the important of water resources. Thus, the recommendations of this paper may help to find solutions to some high priority problems. However, attempts to undertake these actions require careful consideration of prevailing social rules and habits. It is well recognized that any suggested changes of an existing system may bring problems of greater complexity.

REFERENCES

- Costra, M and T. J. Wilkinson. 1987. Traditional Methods of Water Supply. The Journal of Oman Studies, vol. 9. Ministry of National Heritage and Culture, Oman.
- Dutton, R. W. 1984. Modernizing Falj irrigation system: A proposal for a Dhahira action research center. Center for overseas research and development, University of Durham.
- Hayder, A. and I. M. Adel-Magid. 1993. Water conservation in Oman. Water international 18: 95-102.
- Hayder, A. and A. Omezzine. 1996. Aflaj Water Resources Management: Tradable water Rights to Improve Irrigation Productivity. Water International, 21, 70-75.
- Japan International Cooperation Agency (JICA). 1990. The Study on a master plan for agricultural development. Sultanate of Oman. Final Report, Vol. 5.
- MAF. 1995. The Progression of Agricultural and Fisheries Development from 1970 to 1995. Ministry of Agriculture and Fisheries, Sultanate of Oman.
- Marshudi A. 2000. Aflaj Water Resources Mangement: Operation and Improvement of the Aflaj System in Oman. First International Symposium on Qanat. Yazd, Iran Ministry of Water Resources. 1997. Wells Inventory. Sultanate of Oman.
- MRMEW, Ministry of Regional Municipality, Environment and Water. 2002. Aflaj Inventory Report. Sultanate of Oman.
- Norman, W. R. and W. H. Shayya. 1997. Aflaj irrigation water management and efficiencies: a case study from northern Oman. The third Gulf water Conference. "Toward efficient utilization water resources in the Gulf". Vol II Muscat, Sultanate of Oman.
- Rosegrant, Mark W. 1993. Commentary. Markets in tradable water rights could improve irrigation production in developing countries, IFRI Report, Vol. 15, No. 2, 1993.
- Statistical yearbook, various issues. Ministry of national economy, Sultanate of Oman.
- Stanger, G. 1985. Coastal Salinization: A case study from Oman. Agriculture Water Management Journal, vol. 9, pp. 269-86.
- Suttan, Sally. 1984. The Falaj- A Traditional cooperative system of water management, Waterline, Vol 2, No.3.
- University of Durham. 1982. Agriculture, Research and Development Surveys, Northern Oman, Final Report, Vol. IV, A.
- Wilkinson, J. C. 1977. Water and Tribal Settlement in Southeast Arabia. Oxford Research Studies in Geography, Clarendon Press.
- Zaibet, L. and A. Omezzine. 1997. A comparison of economics and Engineering Efficiency in Modern Irrigation in Oman. 37, 99-107.
- College of Agriculture. 1995. Traditional agriculture and Fishing in the Sultanate of Oman. Sultan (continued on page 88)

Prospects of Maize Cultivation Mechanization in Hills of Himachal Pradesh

by

Sukhbir Singh

Assistant Agricultural Engineer
Department of Agricultural Engineering,
Ch. Sarwan Kumar H.P. Krishi Vishvavidyalaya,
Palampur - 176 062
INDIA
srsukhbir@rediffmail.com

Dinesh Kumar Vatsa

Assistant Agricultural Engineer
Department of Agricultural Engineering,
Ch. Sarwan Kumar H.P. Krishi Vishvavidyalaya,
Palampur - 176 062
INDIA
vatsadk@rediffmail.com

Abstract

Maize is one of the major crops of Himachal Pradesh as it is grown in 80 % of the net cultivated area with average yield of 2 t/ha. Research work in the development and dissemination of engineering technologies carried out to mechanize the maize cultivation for the state can play dominant role in augmenting and sustaining the maize production. Seed-bed preparation with power tiller rotary has enhanced the crop yields by 25-30 % in comparison to bullock ploughing and the practice of rota-tilling for maize cultivation is becoming popular among the farmers of this region. Mechanical maize sowing by multicrop planter/manual planter ensured proper crop stand and gave 10-15 % increased yield compared to kera and broadcasting. Similarly, weeding, earthing up and shelling operations by wheel hand hoe, hand ridger/power ridger and different type of shellers produced better results as well as saved labour and

time, respectively. This means that the various operations needed for increasing maize yield have to be mechanized, not necessarily with the costly automatic equipment, but with suitable improved implements suited to local conditions.

Introduction

Maize (*Zea Mays*) is one of the important kharif crops of the Himachal Pradesh, which is grown in 80 % of the net cultivated area with an average yield of 2 t/ha (Anon, 1998) under rainfed conditions. In the maize crop, conventional practices are followed for most of the farm operations, which consume maximum time, energy and cost as well as increase drudgery to the farmers and farm labourers. Also raising of draft animal power is becoming very costly, resulting in enhanced cost of farm operation and ultimately decreasing net returns to the farmers (Varshney and Bohra, 1989; Gupta and Verma, 1990). In

neighbouring plain areas bullock power on the farms of small and marginal farmers is decreasing and the custom-hire system of tractor power is increasing. This system is not feasible, as such, to the hill region because of unique topography and small plots. For this reason, the young farmer generations in many cases are more and more unwilling to stay on farms. A few countries like China, Japan, Thailand, Philippines and Taiwan started the agricultural mechanization programme with the introduction of the power tiller and they have replaced the draft animal power significantly

Fig. 1 Seedbed preparation with power tiller



(Chancellor, 1971; Depeng et al., 1983; Peng, 1983; Singh, 1983). Such a power source may lead to farm mechanization and reducing human physical strain for all the farm operations in the hilly region also. Better cultivation practices, plant protection measures and balanced fertilizer application play a significant role in augmenting the yields. Nevertheless, the adoption of improved processes and modified implements is equally important for better germination, proper plant stand and interculturing, which are the pre-requisites for good crop yields. It is the need of the hour and a challenge to change the agricultural strategy for increasing crop yields through appropriate mechanization to meet the food grain requirement of increasing population.

Research conducted by the scientists on different aspects reveals that decisively higher yield can be obtained by the vigorous introduction of improved tools and techniques. However, it is confronted by technological, economical, physical and social constraints, which must be overcome in order to achieve and maintain production at par with the other leading countries producing maize. This means that the various

operations needed for raising the maize crop yield have to be mechanized not necessarily with the costly automatic equipment, but with improved implements suited to local conditions. To explore the possibility of mechanizing maize cultivation, different farm operations have been reviewed so that hill farmers may benefit.

Mechanization Prospects in Maize Cultivation

Seed Bed Preparation

Land preparation in maize plays a significant role in crop establishment (Maurya, 1988). The seedbed preparation including ploughing, planking, FYM application and clod breaking take up nearly 31 % of the total power required for cultivating maize (Singh, 2002) and hence the choice of the type of implement for seedbed preparation will strongly affect the cost of maize production. The requirements of a good seedbed are:

- i. Fairly deep cultivated, fine and well pulverized;
- ii. Clear of trash, straw, roots,

grasses and stubbles of previous crop, which may hamper mechanical sowing;

- iii. Ample moisture at the time of sowing;
- iv. Levelled for efficient and judicious use of irrigation water and effective working of sowing machines; and
- v. Properly packed and planked to achieve fine tilth and to conserve moisture in the soil.

In hills, farmers mostly use a bullock drawn indigenous/soil stirring plough for seedbed preparation. In most of the region, there is a problem of clod formation after ploughing in clay loam soil and then farmers have to apply extra labour and time for clod breaking which ultimately increases cost of operation with higher drudgery. Field experiments conducted by Vatsa and Singh (1997) to study the effect of seed bed preparation on the traditional bullock drawn system and improved power tiller systems for maize (**Table 1**) reveals that there is a significant saving in cost, time and energy with the power tiller system. **Table 1** also indicates that the field capacity of the power tiller rotavator

Fig. 2 Power tiller operated multicrop planter and manual planter in operation



Table 1 Comparison of power tiller and bullock farming systems

Parameters	Power tiller system		Bullock system	
	Rotavator x 2	Planker x 1	SS plough x 2	Planker x 1
Effective field capacity, ha/h	0.085	0.21	0.026	0.20
Field efficiency, %	75.10	75.26	53.4	71.68
Labour requirement, man-h/ha	11.75	4.76	38.46	5.00
Cost of operation, Rs/ha	816.0	145.9	1,507.70	198.10
Yield, q/ha	27.50		21.22	

Source: Vasta and Varma (1997)

Table 2 Performance of different sowing techniques

Parameter	Sowing techniques			
	PT MCP	Manual planter	Kera	Broad-casting
Depth of seeding, mm	49	47	53	22
Actual seed rate, kg/ha	22	23	27.9	28
Effective field capacity, ha/h	0.175	0.078	0.033	0.027
Labour requirement, man-h/ha	12	38.46	90.9	111.11
Cost of seeding, Rs/ha	417.50	350	850	1,100
Yield, q/ha	28.4	27.1	26.5	24.6

Source: Vasta and Varma (1997)

(Fig. 1) was 3.27 times more than the field capacity of bullock ploughing with a soil stirring plough. However, the field capacity and cost of operation of plunger is almost same for both the power tiller and bullock systems.

Statistical analysis showed that yield under rotatilling twice was significantly higher than the yield under ploughing twice with bullocks. Seedbed preparation with power tiller rotavator should be done to achieve fine tilth. By use of rotavator the problem of clod formation solved and crop yields can be enhanced by 25-30 %.

Sowing and Planting

Sowing and establishing proper plant stand is the most crucial requirement in maize cultivation. On the other hand, farmers using the Kera and broadcasting method of sowing results in poor germination, higher labour involvement and cost. For successful planting of maize, field experiments conducted under AICRP on FIM (Power tillers) on use of the power tiller multi-crop planter (Fig. 2) and manual planter (Fig. 2) indicate that planter can

save 6-7 times labour and 50-60 % cost of operation over traditional sowing (Table 2). There was an increase in yield also due to better plant germination and stand.

Weeding and Earthing up

Weeds compete with the crop plants for soil nutrients, moisture, light and space. Unless weeds are controlled in time, the crop yields reduce drastically. Generally, weeding is done by using khurpi, spade and kudal. The output of these tools is very low and involves great drudgery. By the use of improved weeding tools and implements, weeds can be controlled effectively and timely resulting in higher production and productivity. The hoeing should be done with the wheel hand hoe sweep and tyne type (Fig. 3). Field studies at the Himachal Agricultural University show that the wheel hand hoe double tyne type gives better performance compared to sweep type and local khuntti (Table 3).

The maize crop requires earthing up at least two times. At present this operation is done by manual labour. Therefore, there is a need to mechanize this operation by introducing a suitable hand ridger/power ridger.

Spraying

Plant protection measures are imperative in saving the maize crop from insects and pests. Many different kinds of spraying and dusting machines are available to meet the requirements of agriculturists in controlling insects, disease and weeds. The common type of sprayer is the knapsack sprayer, which can be used in hilly areas. It is provided with a pump and large air chamber permanently mounted in a 9 to 22.5 liter tank. One man can spray about 0.4 hectare in a day thus spraying about 90 liters of liquid. Engine operated, shoulder mounted sprayers are available which are ideal for spraying operations. Since they are very precise in their operation, good care is required in their operation. Where dusting is to be done for the control of pests, manually operated crop dusters are quite effective.

Harvesting

Timely harvesting of cereals crops reduces the risk of weather hazards and clear the fields for the next operations. The most common harvesting tool in Himachal Pradesh is the plain sickle used by the farmers, which has lower capacity and higher drudgery. The plain sickle with impact action is used for harvesting maize, which gives

Fig. 3 Wheel hand hoe

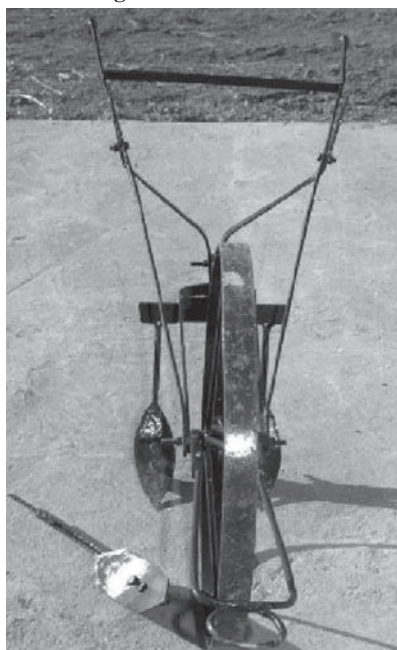

Table 3 Performance of different type of weeders in maize crop

Name of the weeder	Field capacity, ha/h	Weeding efficiency, %	Man-h/ha	Cost of weeding, Rs/ha
Wheel type hoe (sweep type)	0.020	82.5	50	375
Wheel hand hoe (single tyne type)	0.018	83.4	56	420
Wheel hand hoe (double tyne type)	0.030	90.5	34	255
Local Khuntti	0.004	80.5	250	1,875

Table 4 Comparative performance of hand operated maize sheller

Type of maize sheller	Moisture content, %	Grain, kg/h	Shelling efficiency, %
Conventional method	20.8-22.0	8.33	100.00
Octagonal tubular maize sheller	20.8-22.0	14.36	93.00
Rotary disc type maize sheller	20.8-22.0	19.70	86.60
Horizontal maize sheller	20.8-22.0	15.32	96.43
Vertical maize sheller	20.8-22.0	16.80	98.24

Source: Annual Report

better performance as compared to serrated sickle with shear action. However, a power-operated harvester is the need of the hour to easily harvest the maize crop with reduced drudgery. A brush cutter has been used (Vatsa & Singh, 1998) to harvest the maize and higher efficiency was recorded. An additional attachment is required with brush cutter to form windrow for easy collection of stalk.

Threshing/Shelling

Shelling is the removal of grain from the cobs by striking, treading or rubbing and shearing. By the use of various maize shellers, shelling of maize can be done easily and quickly. Beating and hand shelling are the most commonly used practices by the farmers. Hand operated horizontal and vertical maize shellers have been developed (Fig. 4) and evaluated with other methods of shelling under NATP at the University (Table 4). Table 4 shows

Fig. 4 Horizontal and vertical maize sheller

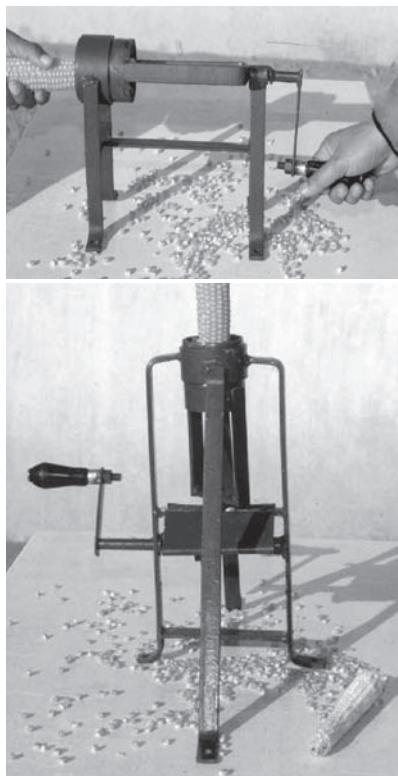

that 72.38, 136.49, 83.91 and 101.68 % higher output can be achieved by using tubular maize sheller, rotary disc type, horizontal and vertical maize sheller than the conventional method, respectively.

Power operated maize sheller evaluated under AICRP on FIM scheme may be used for higher efficiency. This machine consists of hopper, shelling rotors, sieves and blower. The grains are removed by impact and rubbing action between roller and concave grate. The blower helps in cleaning the grain. This maize sheller can be operated by a power source like the power tiller or an electric motor and engine (Fig. 5) and has a capacity of 18-20 q/h.

Conclusion

There is a good scope for mechanizing the maize crop in the hills of Himachal Pradesh by adopting the improved implements for different operations suitable for hills which reduces the time, cost of operation, drudgery over traditional methods.

REFERENCES

- Anonymous. 2002. Annual Report. NATP project- Development of small tools and equipments for mechanized hill farming. Department of Agricultural Engineering, CSKHPKV-Palampur (H.P.), India. April 2001 to March 2002.
- Chancellor, W. J. 1971. Mechanization of small farms in Thailand

and Malaysia by tractor hire services. Transaction ASAE. 14(5): 847-945.

Depeng, Kong, Ling Tongsen, and Zii Gaunggin. 1983. Small tractors in china. Agril. Mechanization in Asia, Africa and Latin America. 14(1): 44-48.

Gupta, M. L. and M. K. Verma. 1990. Comparative performance of power tiller and bullock farming systems in hilly areas. Proceedings of XXVI Annual Conventional of ISAE held at Haryana Agricultural University, Hissar, India.

Maurya, P. R. 1988. Comparison of tillage and conventional tillage under different soils and climatic conditions in Nigeria. AMA. 19(2): 30-32.

Peng, Tien-Song. 1983. The development of agricultural mechanization and its strategies in Taiwan. Agricultural Mechanization in Asia, Africa and Latin America. 14(3): 71-74.

Varshney, A. C. and C. P. Bohra. 1989. Comparative field evaluation of power tiller and animal drawn equipment in wheat production. J. Agril. Engg. 26(1): 19-23.

Vatsa, D. K. and S. P. Singh. 1996. Effect of Various Sowing Techniques under Hilly Conditions. Journal of Hill Research. 9 (2): 255-261.

Vatsa, D. K. and M. K. Verma. 1997. Response of power tiller and bullock based tillage treatment on maize yield in hills of H.P. Journal of Hill Research 10(2): 136-141.



Fig. 5 Maize sheller operated with power tiller



Farm Mechanization in Andaman and Nicobar Island

by

M. Din

Sr. Scientist
Central Agricultural Research Institute,
P.O. Box # 181,
Port Blair - 744 101, Andaman
INDIA
mdin@rediffmail.com

P. S. Deshmukh

Scientist
Central Agricultural Research Institute,
P.O. Box # 181,
Port Blair - 744 101, Andaman
INDIA

N. Ravisankar

Scientist
Central Agricultural Research Institute,
P.O. Box # 181,
Port Blair - 744 101, Andaman
INDIA

S. Ghoshal Choudhuri

Head (NRM)
Central Agricultural Research Institute,
P.O. Box # 181,
Port Blair - 744 101, Andaman
INDIA

Abstract

This paper describes the status of constraints in amenability to agricultural mechanization with respect to cropping pattern, labour availability and manufacturers of implements. During monsoon, a single crop of rice is taken in 10,599 ha of total cultivable land, out of which 47 percent is brought under cultivation more than once in dry season. The present production is not sufficient to mitigate the requirement of growing population due to the limited rain fed area for cultivation and low level of mechanization. The share of human and animal power is highest at 57.32 percent followed by mechanized power at 42.68 percent and the availability of farm power per hectare is only 0.40 kW. Primitive types of and low capacity animal drawn implements are being used for agriculture, horticulture and forestry. The farm mechanization is very poor in terms of mechanical power, matching and efficient

implements and equipment drawn by draft animal power, power tiller and tractor, water management, renewable energy and post harvest activities. Topography, location and proper input non-availability are constraints. Despite them, there is a great need and effort to increase the productivity of food production by proper mechanization inputs.

Introduction

The Andaman and Nicobar group of islands are located in the Bay of Bengal on 6° to 14° N and 92° to 94° E. There is a variety of soil texture ranging from sands along the seacoast to heavy clays in low lands. These islands have maritime climate with temperature between 23.4-30.03 °C and mean relative humidity of 78.4 percent. Annual rainfall of 3,180 mm has temporal and spatial variation. Out of the total geographical area of 8,249 sq. km, 86 percent is under tropical rainfor-

est and 6 percent is under rain fed agriculture. The islands are not self-sufficient in food production. To feed an estimated population of 0.62 million by 2020, about 83,000 tons of rice is required - production of which is a great challenge. Seventy nine percent of total farmers have not more than 4 ha of land.

Buffaloes/bullocks and agricultural workers are the major source of farm power and the farmers still walk behind the plough that is pulled by a pair of buffalo/bullock. Their potential is under utilized due to non-availability of matching implements. Tractor population is low. Farm mechanization is at a low level due to non-availability of improved farm machinery and trained operators. There are more losses in post harvest handling, processing, drying, storing, packing and poor marketing.

To increase food production, productivity of land and labour need to be increased considerably, which will require both higher energy in-

puts and better management of food production systems. Present level of production can be enhanced through mechanized farming by taking three crops in a year without damaging or depleting the natural resources on which all types of agriculture usually depend.

Status of Agriculture

Rice is the principal cereal crop of Andaman and Nicobar islands. Out of the total 50,000 ha available land for agriculture and allied activities, only a single crop of rice is being taken in 10,599 ha during the monsoon period. The climatic conditions permit the raising of two crops from May to December, since a large amount of rain is received during this period. A third crop can be grown during the dry period (Jan-April), which is suitable for raising vegetables/pulses by conserving moisture in-situ and providing protective irrigation to crops (Gangwar et al., 1990; Gangwar and Bandyopadhyay, 1996). The coverage of different crops and their production is given in **Table 1**. The average yield of rice was about 2.68 t/ha.

Presently, 47 percent of paddy area is brought under cultivation more than once, mainly with pulses, oilseeds and vegetables in dry season. Nearly 80 percent of the cultivable area is suitable for plantation crops like coconut, areca nut, spices and tropical fruits like banana, papaya, mango, guava, jackfruit, custard apple and pineapple, due to undulating topography and congenial climatic condition. The area under vegetables can be increased up to 1.7 times of present area by using paddy fallow land in dry season through use of improved implements and soil moisture conservation techniques. By following these practices, cropping intensity can be enhanced to 200-300 percent and productivity of rice and vegetables can be increased with the aim to make these islands self-sufficient.

Animal husbandry supports agriculture in the form of draught animal power (DAP). Farmers also raise goats, pigs, poultry and rabbit (**Table 2**). Numbers of farmers are following the concept of integrated farming in these islands for optimum use of land.

Status of Mechanization

Farm Operations

The traditional cultivation practices consists of various operations which are carried out by hand tools and implements adopted by farmers owning bullocks/buffaloes and tractors for crop production.

Tillage: Land preparation for rice production is the most power intensive operation. The indigenous (wooden) plough and planker are the main animal drawn implements (**Table 3**). Three types of indigenous plough (locally made) are being used in the preparation of seedbed and sowing. These types of ploughs have very low field capacity (30-40 h/ha). A minimum of three to six passes are made for land preparation of paddy and after crops and requires more time and drudgery. The dropping of seed behind the plough does the sowing/planting. This method not only consumes more labour but it adversely affects the crop yield. Wooden puddlers are used for puddling. The clod breaking after opening the land is a severe problem, particularly after harvest of paddy. Most of the farmers are using traditional plankers

Table 1 Area and production of various crops

Crop	Area, ha	Production, tons	Yield, t/ha
Rice	10,599	28,367	2.68
Pulses	878	310	0.35
Oilseeds	167	73	0.44
Vegetables	3,880	18,000	4.44
Coconut	24,996	88.20*	20**
Areca nut	4,000	6,100	1.53
Fruits	3,987	17,500	4.39
Black pepper	428	67	0.16
Clove	93	1.57	0.02
Cinnamon	49	10.37	0.21
Cashew nut	800	262	0.23
Ginger	385	1,198	3.11
Sugarcane	148	4,662	31.5
Gross cropped area	50,410		
Net cropped area	40,382		

* Million nuts, ** Nuts/palm/yr

Source: A status report of directorate of agriculture, Andaman and Nicobar administration (2000)

Table 2 Animal population

Category	Number
Cattle	60,180
Male over 3 years	16,048
Male young stock	9,155
Female	34,977
Buffalo	14,204
He-buffalo over 3 years	4,729
He-buffalo young stock	1,822
She-buffalo	7,653
Goats	70,923
Pigs	42,836
Horses and Ponies	8
Donkeys	7
Rabbits	162

Source: A status report of directorate of agriculture, Andaman and Nicobar administration (2000)

for clod breaking in paddy fields for sowing of vegetables/pulses.

Transplanting: Transplanting is done manually with raised nursery. Farmers generally transplant indigenous, long duration paddy varieties with maximum 60-day-old seedlings at their convenience. In some areas, vegetables/pulses/oilseeds follow paddy. The costly labour prohibits farmers to go in a big way for more of crops. Drills/planters are not available with the farmers surveyed. Other than paddy, all field crops are generally transplanted/planted in furrow opened by plough.

Inter-culturing: Due to conducive atmosphere for growing of flora, all types of weeds and mushrooms grow in the paddy and vegetables fields. Interculturing is a very tedious, energy intensive and time consuming operation carried out manually. In paddy, uprooting of weeds is done while in vegetable/pulses, oilseed interculturing is done with the help of traditional hand hoe (kharpa). Herbicides are applied in paddy.

Plant protection: The incidence of pest and diseases are greater because the high humidity is conducive for their growth. Plant protec-

tion is done by sprayers and dusters, which are available on a rent basis from the Department of Agriculture. The technical knowledge of farmers on use of chemicals is very low. High spray volume and inefficient spraying technique for chemicals is proving costly to humans and, in the long term, may be to ecology also. Farmers are using the chemicals in a big way because the Department of Agriculture is supplying them free/at a nominal rate. Proper awareness of the use of chemicals is the need of the hour.

Harvesting: Harvesting is an arduous function to perform. Farmers use plain sickles for harvesting of crops and grasses because only these are available at a low cost. The output through the sickle is low and the effort required in cutting operation is high. Horticultural produce is also harvested manually.

Threshing: Threshing of paddy is done manually or by animal trampling. By this method, losses are quite high. Man and animals get fatigued during threshing operation due to tropical climate. Pedal threshers are available only in the Department of Agriculture.

Post harvest operations: Farmers are following the traditional method for drying of paddy, coconut and areca nut. Rice is hulled by hullers in which breakage of grains is high. Uncertainty of rain makes it difficult to dry rice under sun. Coconut and areca nut are dried in smoke dryer, which degrades the quality. The post harvest losses in quality and quantity of rice are very high as farmers have their own way of parboiling, storing and processing farm products. There is no modern rice mill, coconut oil extraction plant, cashew-processing plant, pulse mill or processing equipment for spices.

It shows that transplanting; interculturing, harvesting, threshing, drying and winnowing are done manually both on the animal and tractor farm. Transplanting, interculturing and harvesting are the most labour intensive, drudgery-laden and expensive operations in rice production. The use of improved farm implements is very low in the Islands as compared to mainland India. Primitive types of hand tools are being used for agriculture, horticulture and forestry.

Table 3 Agricultural implements and hand tools

Implements	Number
Wooden plough	10,309
Soil string plough	333
Sprayer/duster	1,914
Planker	8,351
Wooden puddler	65
Diesel engine pump set (5.0 hp)	881
Electric pump set (1.0 hp)	36
Tractor	121
Power tiller	12
Disc harrow	16
Thresher	141
Sugarcane crusher	172
Ghanis	22
Secateur	2
Grafting and budding knife	7
Garden hoe	1,455

Source: (i) Live stock census 1997, Directorate of animal husbandry and veterinary services, Andaman and Nicobar administration, (ii) A status report of directorate of agriculture, Andaman and Nicobar administration (2000)

Table 4 Major sources of farm power

Source of power	Number	Average power, hp	Available power, hp
Agricultural worker	19,514	0.1	1,951.4
Male cattle over 3 years	16,048	0.5	8,024.0
He-buffalo over 3 years	4,729	0.5	2,364.5
Tractor			
a. Agriculture office	65	45.0	2,925.0
b. Farmers owned	56	30.0	1,680.0
Power tiller			
a. Agriculture office	4	12.0	48.0
b. Farmers owned	8	12.0	96.0
Diesel engine	881	5.0	4,405.0
Electric motor	36	1.0	36.0
Total available power, hp			21,529.9
Net cropped area, ha			40,382
Per hectare power available, kW			0.40

Source: Basic statistics (1996), Directorate of economics and statistics, Andaman and Nicobar administration

Manufactures/Workshop Facility

Fabrication of hand tools like khurphi, spade, garden hoe, dab, coconut dehusker, areca nut cutter, crowbar, pick axe, rake, digging hoe, grass cutter blade, plane sickle, wooden plough, wooden harness, wooden planker and wooden puddler, is done by local artisans only. There is no genuine workshop for repair of animal, power tiller and tractor drawn implements

Farm Power Availability

The availability of farm power per unit area (kW/ha) has been considered as one of the parameters for expressing level of mechanization. At present, the availability of farm power is 0.40 kW/ha (**Table 4**) in the islands whereas the national average is about 1.29 kW/ha as reported by Singh (2001). The study revealed that human and animal power is higher at 57.32 percent, while the mechanized power is only 42.68 percent. The availability of farm power in the islands is very low and has much need for further mechanization. Agricultural workers, draught animals, power tillers, tractors, diesel engines and electrical motors are the sources of farm power. These are as discussed below.

i. Human and Animal Power Sources

Agricultural workers are the main source of farm power for operating hand tools and implements. They are utilized for operations like seed bed preparation, seeding/transplanting, fertilizer application, ridge formation, dusting/spraying of insecticides/herbicides, water lifting, intercultural operations, harvesting, on-farm transportation, threshing and winnowing. As per 1991 census there were 19,514 agricultural workers in these islands and it is estimated that 1951.4 hp is available from agricultural workers, assuming that average power developed by agricultural worker is equivalent to 0.1 hp. Thus hu-

man power contributes 9.07 percent of the total farm power available (**Table 4**).

Male bullocks and buffaloes are the main source of draught animal power (DAP). In the year 1997, the total population of bullocks and he-buffaloes aging over 3 years of age, were 16,048 and 4,729, respectively. They were used as draught animals by the farmers and are subjected to various agricultural operations like tillage, puddling, sowing and threshing. Buffaloes are also used for lifting of woods from the forest. Considering that a single bullock/buffalo can develop approximately 0.5 hp, the total DAP is 10,388.5 hp. At present, the draught animals contribute 48.25 percent of total farm power. This shows that DAP contributes higher than other mechanical sources. It appears that animal power will continue for more years in maxim.

ii. Mechanical Power

The second important source of farm power is mechanical power, which is available through tractors, power tillers and diesel engines and electrical motors. As the farmers of these islands are economically backward and have smallholdings, they are not in a position to purchase tractors and power tillers themselves. Therefore, since 1987-88 the government has provided 30 percent subsidy for the purchase of tractors and power tillers (free transportation) under promotion of agriculture mechanization. In this scheme, a total of 56 tractors and 8 power tillers have been provided to farmers. Three matching improved implements like seed-cum-fertilizer drills, puddlers, cage wheels and trailer are given to farmers with the tractors. Besides this, the agriculture department has 65 tractors and 4 power tillers. The government provides tractors at the concessional rate of \$2.22/hr on a custom hiring basis, whereas farmers having their own tractor charge of \$4.44/hr. Some of the farmers use tractors on

a custom hiring basis for tillage and puddling operation. Thus, tractors are replacing the draft animals to some extent. At present, 56 tractors of 30 hp, 65 tractors of 45 hp and 12 power tillers of 12 hp are in use for agricultural operations. The total number of diesel engines supplied by the Government of India on subsidy is 881 of 5 hp each and this is equivalent to 4,405 hp. Pumps are used for pumping irrigation water. Thus, the total mechanical power worked is 9,154 hp. There are 36 electrical pumps (1 hp each). The pumps are used for irrigation. Thus, the mechanical sources contribute 41.75 percent of total farm power available.

Mechanization Potential

The farmers face difficulties in timely completion of field preparation for an area of 10,599 ha under paddy spread all over the union territory due to shortage of labours, draught animals and mechanical power. Thus, the production of rice is often hampered by lack of mechanization inputs like improved implements for tillage operation, puddling, sowing, interculturaling, harvesting, threshing, modern rice milling and of irrigation equipment.

The farm power availability at 0.40 kW/ha has potential for increase, as it is much below the national average of 1.29 kW/ha. There is tremendous need for the tractor, lightweight power tiller and their matching implements to increase the cropping intensity. In these islands, animal power utilization is only 300-400 hours annually (as against ideal utilization of 2,500 hours) due to the limited period of use for tillage, sowing, and puddling operations. For a very less time, they are used for transportation. Farmers have to spend the money on the maintenance of draught animals for the entire year. Thus, the animal power is wasted without its optimum uti-

lization. However, it is not possible to replace completely the animal power with the mechanical power. Besides, the islands have a good number of draft animals as Animal Husbandry supports agriculture in the form of draught animals. To maintain an eco-friendly system in these islands, there is a need to test and popularise animal operated improved matching implements for tillage, sowing, transplanting, and intercultural operations. This will increase the efficiency of animal and reduce the drudgery of framers.

Efforts to increase rice production should focus on minimizing losses that occur during harvest and post-harvest operations like threshing, transporting, drying and storing. It is estimated that about 10 percent of paddy produced is lost in the above operations including milling. Rice yield could be increased by 2 percent with improved mechanical drying, 1-2 percent by the modern methods of parboiling and mechanical drying and 2-3 percent with improved milling equipment. The surplus vegetable and fruit production could be processed and utilized for dry season. Seasonal, leafy vegetables and fruits like mango, jackfruit, coconut, pineapple and milk could be used for value addition, resulting in island organic products. This will help in reducing the supply-demand deficit in non-availability season.

There is a great need and effort to increase the productivity of paddy, pulses, oilseeds, horticulture and forestry by use of matching implements like mould board plough, ridger plough, patella harrow, cultivator, disc harrow, animal drawn puddlers, sowing and planting machines, hand wheel hoe, improved sickles and power operated thresher and winnower.

Conclusion and Suggestions

The agricultural mechanization

in the islands, is still in its infancy, has tremendous potential and merits its immediate attention. There is tremendous scope for agricultural mechanization through the use of improved matching implements for animal, power tiller and tractor drawn implements, and the optimum utilization of alternative and renewable energy sources for increasing cropping intensity and boosting production without causing any harm to the fragile ecosystem of these islands. Some suggestions for enhancing the pace of mechanization in these islands are as follows.

- i. Development of a proper agricultural engineering package for these islands.
- ii. The technology of equipment from other research organizations needs testing, evaluation and modification for their adoption to island conditions.
- iii. Demonstrations on DAP, power tillers and tractor drawn implements should be arranged at the farmers field and farmers should be trained regarding the operation and maintenance of these improved implements.
- iv. Creation of repair facility with a supply of genuine spare parts of farm machinery. Small-scale manufacturers of implements should be encouraged.
- vii. Research and development activities in post harvest and agro processing should be enhanced.
- viii. Proper harnessing of human and animal power is required to utilize its full available potential for sustainable agricultural production maintaining the crucial eco-balance.

REFERENCES

- Anon. 1996. Basic Statistics. Directorate of economics and statistics, Andaman and Nicobar Administration.
- Anon. 1997. Live stock census, Directorate of Animal Husbandry and Veterinary services, Andaman and Nicobar Administration.
- Anon. 1997-98. Annual report, Central Agricultural Research Institute, Port Blair.
- Anon. 2000. A status report of Directorate of agriculture, Andaman and Nicobar Administration
- Gangawar. B. and A. K. Bandyopadhyay. 1996. Agricultural production manual for Andaman and Nicobar islands, Central Agricultural Research Institute.
- Gangawar. B., A. D. Mongia, and A. K. Bandyopadhyay. 1990. Rice based cropping systems for Bay islands, Central Agricultural Research Institute, Port Blair.
- Singh, Gajendra. 2001. Relationship between mechanization and Agricultural productivity in various parts of India. *AMA*, Vol. 32(3): 68-76



Current Status of Animal Traction in Mexico

by

H. Ortiz-Laurel

Professor

Campus San Luis Potosi,

Postgraduate Colledge

Iturbide 73, Salinas de Hgo., S.L.P. 78600

MEXICO

hlaurel@colpos.mx

D. Rössel

Professor

Campus San Luis Potosi,

Postgraduate Colledge

Iturbide 73, Salinas de Hgo., S.L.P. 78600

MEXICO

edietmar@colpos.mx

Abstract

In Mexico there is a wide contrast of farming activities. Much of farmland (5,574,770 ha) is cultivated by small farmers (2,243,138 holdings with < 5 ha), yet, some regions are already highly mechanised, and in other areas machinery contract services are available to farmers. To meet the demands for increased crop production it is necessary for the small farms to adopt improved technology including some mechanisation of farm operations, and for the larger farms to keep abreast of current developments in agricultural technology. In Mexico, the development of farm machinery utilisation is quite progressive, as previous government policies have greatly favoured tractors and discriminated against animal-powered methods. Still much of the land (5,885,400 ha) is tilled by a great number of working animals (3,765,774). Draught animals are the most important power source in the less fertile regions. Twenty five per cent of total power provided to agriculture comes from bovines and equines. Mexico has undertaken programs to encourage improved management and the use of animal-drawn equipment appropriate to the needs of small

farmers, but the results have been disappointing. Local manufacture of promising implements was also encouraged. Although, the marketed equipment has been trailed and used with success and both technical performance and customer acceptability has been good, it did not further impress the farmer. This study shows that constraints for adopting this low-power technology exist, of which the most important are probably small farmers low purchase power and lack of reliable extension services.

Introduction

Mexico is located between 14 and

33 degrees North latitude and covers an area of about two million sq. km. It has boundaries with the United States of America on the North, the Gulf of Mexico on the East, the Pacific Ocean on the West, and the Republic of Guatemala on the Southeast. According to the 2000 census (INEGI, 2000), the total population of Mexico is about 100 million inhabitants. Labour force accounts 33,730,210 and those engaged in agriculture are 5,338,299 (15.8 %). The total area that can be cultivated is about 108.35 million hectare and 28.7 % is farmland; 62.1 % is permanent pasture; 8.1 % is forest and jungle; and 1.1 % is idle land (**Table 1**). From 31.1 million ha dedicated to crops, 3.8 million ha are fully ir-

Table 1 General situation of Mexico agriculture

Farmland, 10 ⁶ ha	31	Average size of farmland plots, ha	12.1
Arable land, 10 ⁶ ha	23	Number of tractors	170,000
Irrigated land, 10 ⁶ ha	18	Number of combines	20,000
Agricultural farms, 10 ⁶	3.8	Tractorization index	0.3501

Table 2 Contribution of each draught power source to Mexican agriculture

Primarily power source	Tractor, %	Animal, %	Combination, %	Human, %
Tractor	28.4	24.7	17.0	29.9
Animal	12.6	2.6	2.4	82.4
Animal-tractor	61.0	12.7	14.0	12.3
Human	29.8	37.3	25.0	7.9
Human-animal-tractor	11.8	44.3	14.1	29.8

rigated, 23.2 million ha are rainfed and 4.1 million ha are cultivated via irrigation/rainfed (INEGI, 1994).

Commercial agriculture is localized in small and already defined micro-regions that have suitable conditions for specialized farming, including irrigation and good rainfall season, high level of technology, and where farmers are private owners with high capacity for investment and able to obtain external funding.

There is a significant geographic mismatch between water resource and population of Mexico. Only 12 % of the nation's water is in the Central Plateau where 60 % of the population and 50 % of the basic cropland is located. On the other hand, more than 50 % of Mexican territory is semi-arid where human activity in agriculture depends upon low, seasonal and ill-distributed rainfall, and the regions are vulnerable to droughts and other climatic variations. These zones are principally located in the North and Central part.

There is also the existence of uneconomic-sized holdings where the production of crops generate low-returns, traditional methods of pro-

duction are used, there are restrictive conditions to cropping patterns and there is inadequate access to agrosupport services in many cases. This small-scale sub-sector represent 2,243,138 holdings that cultivate 5,574,770 ha, with an average farm size of 2.5 ha. Furthermore, there is a high risk of soil degradation as farmers utilize inadequate farm practices. It is estimated that in these regions 8 out of 10 farmers raise basic staple crops for their own consumption. In these less fertile regions, mechanisation still is relatively expensive for the farmer, and better animal-drawn implements remain the more suitable means of increasing productivity.

Mexico's preferential treatment of the large-scale sub-sector in agriculture (an average farm size larger than 5 ha) has had serious negative consequences for the country's small-scale farmers. In the past, the government heavily subsidized tractor services. However, the need to curtail government expenditures has made the government less willing and less able to continue tractor subsidies. Nevertheless, government investments in research, irrigation and other types of rural infrastruc-

ture have benefited mainly these large-scale farms (102,771,315 ha are farmed by 1,579,932 holdings).

It is appreciated that there is a large potential for increasing agricultural production by raising the present low levels of productivity of the country's small farms. However, another now common characteristic of the unorganised, traditional, small-farm sector is the ageing of the labour force due to the out-migration of the younger, more educated, family members to the urban areas. Three basic energy sources are used for agricultural work in Mexico: farmer/manual tools, farmer/animal power, and farmer/machine systems. In fact, these systems are usually found side by side, though they vary in their size, distribution and relative importance (Table 2). It is a fact that improved technologies for tools and implements are still being developed for each source of power.

Small farmers are typically dependent on animals or human power for most field work and transportation. However, when quality and timeliness are important factors, farmers often do the ploughing and other land preparing operation with the help of a hired tractor. Farmers hiring tractors use them mainly for ploughing and heavy tillage operations.

Traction Power Applied to Agriculture

Historically, draught animal technology has been used to increase the area cultivated, not the yield per unit of land. The uses of animals for cultivation does not reduce the amount of physical labour required as the farmer still must walk the same number of kilometres as the animal, and guiding the implement and the animal requires considerable effort. Under all systems of farming work animals are used an average of 30 days per year in actual field opera-

Fig. 1 Distribution of power applied to agriculture in Mexico

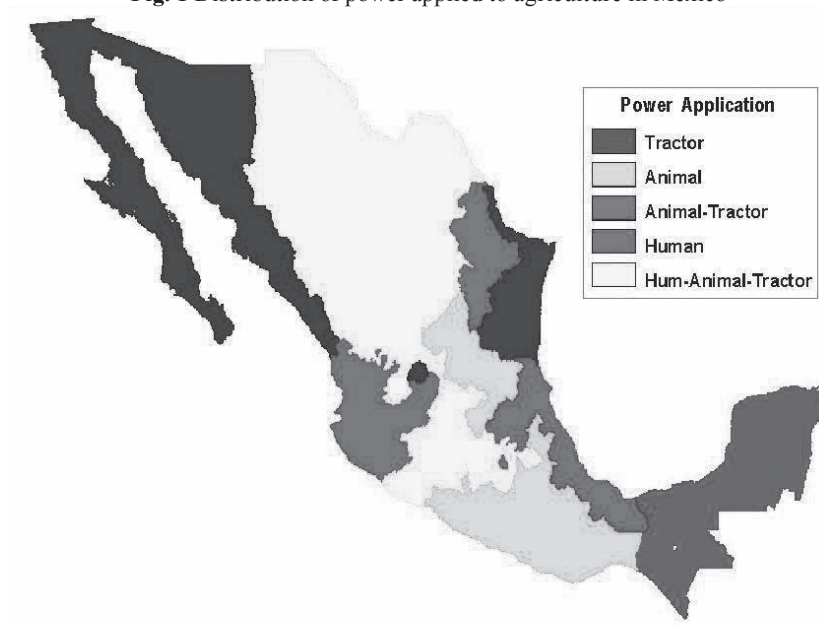

tions and more intensively at some times of the year than at others. The most crucial time is during the season of land preparation and seeding. At this time, feed supplies are most limited in both quality and quantity. The problem is compounded by the fact that the ground is still very hard and temperature is often at the seasonal peak. The animals at this time may be able to work only very slowly or may be too weak to work at all. Consequently, land preparation takes a long time and planting is delayed with a risk of the rains ending before the crop has matured. However, despite to the wide range of climatic, soil types, topography and agricultural production systems, draft animals are still widely used by small farmers. The distribution of power application in agriculture (**Fig. 1**) shows that human, animal traction, and a combination of mechanical power and work animals systems are located in the low-resource areas. This sharing of power source for farm work illustrates the level of technology achieved and draws the required action for improvement (Rubio Granados, 2000).

According to INEGI, (1994) from the 3.8 million land holdings, 20.2 % employed tractors, 29.7 % used draught animals, 15.6 % employed a combination of animals and tractors, and 32.5 % used human force (**Table 3**). Also, 3.7 (6.25 %) out of 10 holdings owned a tractor. In the decade of 1970, 41 % of arable land was tilled by rented equipment and 35 % with tools owned by farmers. Tractors have been employed on highly productive ground, levelled and irrigated farms larger than 15 ha, and with access to machinery and service workshops.

Land size per holding is still very low in Mexico, as in 1991, 60 % of holdings were of 2.09 ha in size. INEGI, (1994) assumes that 62.2 % of agricultural land is still cultivated with draught animals and human force. Alternatively, 16 million ha of farmland are susceptible to be

farmed by mechanical power. According to Masera, 1990, cropped farmland to produce maize employed tractors on 20.0 %, a combination of animals and tractors on 31.0 %, draught animals on 34.1 % and human power on 15 %.

The animals have special importance for efficient operation of small farms as they are mainly employed for ploughing, packing and cart pulling. The population of working animals had a fast stride after the 1910 civil war. This trend continued until it reached a maximum in 1970 (**Table 4**). In the 20 years after 1970 the number of farm animals reduced by 46 %. Only recently were donkeys considered as work animals, because of the assumption was that they were used mostly as pack animals and did little traction work. Alternatively, human energy as power source for farm work has been associated with the slash-burning system and with traditional subsistence farming on very small and hillside plots.

Animal Traction Research

The main emphasis in this area has been in development of improved mechanisation systems for the small-scale farmers. They are typically dependent on animals or human power for most fieldwork and transporta-

tion. The foremost ways through which the performance of draught animals as a source of power in agriculture can be improved are the design or improvement of the harness, research into the performance of soil engaging tools and improvements in the design of animal-drawn equipment (Ortiz Laurel, 1992). Studies about physiological and welfare (health and nutrition) aspects on animals have not been conducted because they are considered of less importance in the research centres in Mexico. Most of harnesses and accessories needed for draught animals are produced locally including tillage tools. The most common method of harnessing bovines to an implement or cart is by means of a wooden yoke attached to the head, with the animals hitched in pairs abreast. In Mexico, the bovines do not generally have humps, so the yokes are fastened to their horns (**Fig. 2**). Manufacture of the yoke is expressly on order. It is thoroughly hand-made and follows an artesian tradition. The cost of yoke varies from region to region regarding availability of local materials, it can be found from 50 to 70 USD. The most visible and common problem found in bovine teamwork is the size difference of animals hitched together.

Equines are fitted with the full collar harness, which is considered as the more comfortable and ef-

Table 3 Numbers of holdings and agricultural land according to type of power source

Power source	Holdings	Farmland, 000ha	Power source	Holdings	Farmland, 000ha
Tractor	828,258	3,492.6	Human	717,267	10,706.1
Animal	796,785	5,885.4	Human-animal-tractor	444,940	2,440.9
Animal-tractor	1,011,643	7,993.6	Total	3,798,893	30,518.6

Table 4 Population of work animals in Mexico

Type	1930	1940	1950	1960	1970	1980	1990
Bovines	1,776,418	1,868,429	2,083,826	1,659,325	1,661,571	746,764	623,794
Horses	641,742	480,143	976,006	978,508	1,426,170	653,418	865,853
Mules	383,185	447,276	859,773	838,563	1,061,700	466,728	749,009
Donkeys							1,527,118
Total	2,801,345	2,795,848	3,919,605	3,476,396	4,149,441	1,866,910	3,765,774

Adapted and updated from Cluz Leon (1994)

ficient device through which transmission of draught pull is fully achieved (Fig. 3). However, good management has been difficult to accomplish as mixed teams - horse and mule - are frequently seen and in some teams a marked difference in animals size was also observed. The cost of a full collar assembly ranges from 35-60 USD.

Research on the performance of drawn animal tools has been done at a local level and the results have had a little impact on reducing draught significantly but the cost of the modified tool has increased because of special materials employed and additional maintenance required (Fig. 4). In addition, experiences obtained cannot extensively be applied to the wide range of different soil types and regional tools. Thus, research has focused on implement design with the idea that a suitable harness has to be complemented by light-weight implements (ploughs, cultivators, ridgers, harrows, seeders, etc.) coupled to a common frame.

Cultivation System Under Animal Traction

Power mechanization with conventional equipment is unlikely; however, to be economic in marginal semiarid areas where the cash return per hectare is low. Thus, there was a growing interest in animal draught systems, with the main emphasis in this field was in supplying low-power equipment to be used

with animals. For the equipment for small farms to be successful, it will be necessary for manufacture to be accurately made, low cost, preferably made near the area of use. New options are now available to farmers because of recent improvements in the design of multipurpose tool-bars, reversible ploughs, wheeled tool-carriers (Fig. 5), seeders/fertilizers (Fig. 6) and disc harrows (Sims et al., 1988). It could be expected that better field equipment would mean that land could be cultivated in a shorter time with less effort, and crops sown earlier in the rainy season. The critical test of the economic worth of such equipment is whether or not the equipment's cost and performance characteristics make it in the self-interest of individual farmers to adopt it.

One of the challenges for farmers is to solve the technical problems for adopting the wheeled tool-carrier concept. Social/economic questions are probably more crucial since it will be uneconomical for the small farmer both to own a tool-carrier and still hire a tractor for heavy cultivation. Alternatively, several components on the equipment had to be strengthened because draught cattle used in Mexico are generally larger and stronger than in other countries, making it heavier and more robust than the original toolbar from which it was developed (Sims and Aragon Ramirez, 1989). Nevertheless, work is still proceeding to develop and adapt more implements in order that it may be more versatile.

Animal Traction Mechanisation Programs

Animal tools mechanisation programs have had modest success in obtaining a commercial manufacture of new, improved equipment. Many significant mechanical innovations have been invented and developed by small rural machine shops working closely with local farmers. The aim has been to reduce drudgery on the farms, to increase yields by improved timeliness of operation, and to improve the balance of labour demand over the year. However, such programs have generally failed to establish a close and long term working relationship among researchers, farmers, and manufacturers to insure that the proposed equipment is cost-effective. Since only when the necessary equipment is manufactured and sold can the farmer apply the recommendations arising from the research programme. The farmers expressed general appreciation for the technical advantages of the improved implements, but faced serious financial constraints due to low incomes and the lack of credit. Some of the factories make and sell the tools only when they receive orders and there is no effort to promote their equipment at field demonstrations or at farm fairs. Other manufactures expressed financial concerns and noted difficulties associated with technical ability and promotion and marketing. This is the case for wheeled tool-carriers that have been

Fig. 2 A hitched team of bovines carrying cultivation work



Fig. 3 A team of horses using the full collar harness



Fig. 4 Field testing of an improved animal drawn tool



rejected because of their high cost, heavy weight, lack of manoeuvrability, inconvenience in operation, complication of adjustment and difficulty in changing between modes.

The technical problems associated with manufacturing the new equipment fall into three categories: availability of materials, knowledge of the fabrication techniques, and availability of the necessary equipment. Most manufacturers do not have the machine tools and other equipment needed to produce the implements, and awareness about prospect of sales may not justify investing in new equipment.

Dissemination and Marketing Difficulties

Most manufactures do not conduct a proper form of market survey. They work exclusively on order, claiming that they are fearful of carrying large stocks because small farmers might have trouble paying. This reduces their willingness to anticipate future sales. Manufacturers recognise the role that improved animal-drawn tools could play in increasing their product range and reducing idle productive capacity. But they always point out the problems of the low and insecure purchasing power of the potential clientele in explaining why they fail to produce such equipment. On the other hand, small farmers find that animal drawn equipment is highly durable and this attribute limits replace-

ment demand. Despite that, small, regional, rural workshops continue to make batches of ploughs and seeders for specific crops. A sound estimate is that fifteen to twenty companies in Mexico are still currently manufacturing animal-drawn equipment.

Discussion

The small farm sector is not without its share of problems stemming, in part, from the widely disparate performance in the country's two farming segments. On the one hand, the organised, commercial sector has achieved levels of productivity increases in crop yield and produced quality. On the other hand, the poorly organised traditional, small-farm sector is "locked" into less efficient production methods and producing crops often of low economic return.

Improving the performance of animal-drawn equipment is an attractive possibility where most of the small-scale farmers rely entirely on animal draft power. This study does not suggest or even emphasize that it may be economically more efficient for farmers to use improved animal-drawn equipment than to hire tractors for ploughing and disking. But, diffusion of the new farm tools has been retarded by the subsidisation of tractor services. On the other hand, agricultural extension workers have given little attention to farm equipment innovations and often lack the knowledge required

to advise farmers concerning animal-powered and other inexpensive equipment that could increase land productivity. It will be necessary to demonstrate, convincingly, to farmers and to extension services that low energy input cultivation can produce crops equal to those achieved after tractor cultivation.

This type of power will continue within Mexican agriculture yet for many years to come. As there are holdings exclusively for draught animals. However, it is important to emphasise that animal power will continue to be predominant on those marginal regions and where crops are grown for self-consumption. While mechanical power will continue increasing steadily as long as the farmers can afford to hire and to own this equipment.

Conclusions

About 5.4 % of Mexico's cropped land which is under holdings of less than 5 ha will continue to depend heavily on animal power. The middle group of 5-20 ha holdings can afford to use mechanical power in an increasing manner and their dependence on animal power will be substantially reduced. Land holdings greater than 20 ha will hardly depend on animal power. Many of those new improved animal-drawn designs have failed to impress farmers for a variety of reasons - mainly technical, economic, and agronomic and, often, because of the lack of sufficient training and deficient extension services. Refusal to purchase the multi-purpose tool-bar equipment is because of the relatively higher cost of the attachments and its rather limited use.

Fig. 5 A pair of bovines ploughing with a wheeled carrier



Fig. 6 field trials on an animal drawn seeder/fertiliser



REFERENCES

- Cruz Leon, A. 1994. Tracción animal en la agricultura de México (Animal traction in Mexican

- agriculture). Unpublished MSc. Thesis. Colegio de Postgraduados. Mexico. p 298.
- INEGI. 1994. (National Institute for Statistics, Geography and Informatics) - VII Censo Nacional Agropecuario (National Agricultural-Livestock Census). Tomos I y II. Mexico.
- INEGI. 2000. (National Institute for Statistics, Geography and Informatics) - XII Censo General de Poblacion y Vivienda (General Census on Population and Housing). Mexico. <http://www.inegi.gob.mx/est/contenidos/espanol/tematicos/mediano/>. Accessed 15 October.
- Masera, C. O. 1990. Crisis y mecanización de la agricultura campesina (Crisis and mechanisation of peasant agriculture). El Colegio de Mexico. Mexico. 226.
- Ortiz Laurel, H. 1992. Medición de fuerzas de tracción en animales de tiro (Measurement of traction forces on draught animals). Proceedings of the II National Congress on Agricultural Engineering. México. A59-A63.
- Rubio Granados, E. 2000. Catálogo de Tecnología Intermedia (Intermediate Technology Catalogue). Secretaría de Agricultura, Ganadería y Desarrollo Rural. Mexico. 3-26.
- Sims, B. G., B. F. Johnston, A. L. Olmstead, and S. Jacome Maldonado. 1988. Animal-drawn implements for small farms in Mexico. Food Research Institute Studies. Vol. XXI (1). 69-95.
- Sims, B. G. and A. Aragon Ramirez. 1989. Draft oxen energy expenditure: a Mexican case study. Agricultural Mechanization in Asia, Africa and Latin America. Vol. 20 (2). 9-14. ■■

(Continued from page 73)

Oman Traditional Farms: Changes and Improvement of Farms in Oman

- Qaboos University, Sultanate of Oman
- FAO. 1997. Oman Agricultural Review, ROM. WWW.Oman.net/fao/htmlp
- MAF. 1993. National agricultural census. Sultanate of Oman
- Omezzine, A., H. Chebaane, and L. Zaibet. 1997. Reallocations of agricultural water in Oman A potential advantage in higher valued crops. International Symposium on water and Arab Gulf Development, Center of Arab Gulf Studies, University of Exeter, UK
- Al-Ghafri, A. and W. R. Norman. 2000. Traditional Irrigation Scheduling in Aflaj Irrigation system of Oman. Aflaj Maintenance in the Sultanate of Oman. Paper presented in the First International symposium on Qanat. Yazd, Iran
- Al-Hatmi, H. K. and S. S. Al-Amri. 2000. Aflaj Maintenance in the Sultanate of Oman. Paper presented in the First International symposium on Qanat. Yazd, Iran.
- Al-Rawazi, A. and A. W. Hago. 1999. Contruction problems in traditional irrigation systems: A case study from the Afalj of Oman. Chapter in water management Purification and Contruction in arid Climates. Edited by Goosen, M. F and W. H. Shayya. Technomic press. ■■

354

A Criteria for Assessing Storage Buildings: Richard Jinks Bani, Professor, Agricultural Engineering Department, University of Ghana, Legon, Ghana; Brian Stenning, Cranfield University, Silsoe Campus, UK.

This paper reports the use of a simulation model to identify critical factors affecting the indoor temperatures in stores. A steady state heat transfer analysis was used. The effects of infiltration, solar radiation, transmittance and absorptance were studied. Infiltration was observed as the highest contributor to the heat flux in stores contributing as much as 84.85 % in some cases. For highly insulated stores solar radiation and surface absorptance had very little effect on the store temperatures. Increases in surface transmittance increased the store temperatures by small amounts up to 0.14 °C and 0.24 °C when transmittance values were doubled and tripled respectively. Based on their contributions to the store heat flux it can be concluded that stores can be assessed based on their ability to minimize fluctuations in infiltration during the storage period.

380

Dynamics Analysis and Test of Seedling-Pushing Device in Transplanting Mechanism with Ellipse-Circle Planetary Gears: Zhao Yun, Professor, Zhejiang Institute of Science and Technology, Hangzhou, Zhejiang 310033, P.R. China; Zhao Fengqin, Associate Professor, Shenyang Agricultural University, Shenyang, Liaoning 110000, P.R. China; Chen Jianneng, Associate Professor, Fujian Agriculture and Forestry University, Fuzhou, Fujian 350003, P.R. China.

In order to set up the dynamics model of the transplanting mechanism with ellipse-circle planetary gears of high-speed rice transplanter, the effect of seedling-pushing device on the mechanism must be analyzed. The dynamics characteristics of seedling-pushing device were analyzed by method that was derived by us. The method is analytical form differential equations of rigid compound motion. As a result, dynamics model of seedling-pushing device was deduced. By programming calculation, some conclusions were drawn: (1) the relationship between the angle of gears trunk and the angle of shifter and the position of seedling-pushing rod in the course of seedling-pushing and collision, (2) the relationship between the angle of gears trunk and the bearing force of spring, shifter shaft and seedling-pushing rod in the course of seedling-pushing and collision. The first relationship was tested and proved by high-speed video camera, which can prove the second relationship indirectly. These conclusions were the bases to analyze this kind transplanting mechanism.

386

Development of a Low Cost Motorized Cowpea Dehuller: K. Oje, Department of Agricultural Engineering, Faculty of Engineering and Technology, University of Ilorin, P.M.B. 1515, Ilorin 240003, Kwara State, Nigeria; A. M. Olaniyan, same.

The drudgery involved in the post-harvest processing of cowpea, particularly in the dehulling of the seeds to obtain clean beans for further processing, has resulted in the decline of the local production of food items that have this product as its main raw material. A motorized cowpea dehuller was designed (Fig. 1), fabricated and tested for its performance. Result of tests conducted indicated a maximum dehulling efficiency of 74.96 % at the dehulling time of 8 minute. The machine was designed having in view the techno-economic status of the rural dwellers who are the major small-scale processors of cowpea.

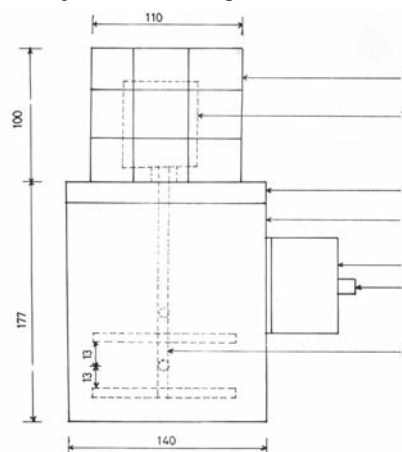

Fig. 1 Side view of the cowpea dehuller

A: electric motor housing, B: electric motor, C: cover, D: container, E: regulator, F: regulating switch, G: dehulling unit (all dimensions in mm)

390

Performance of Pneumatic Seed Metering (Pressurized) Device for Paddy in Puddle: H. M. Khobragade, Senior Research Fellows and Principal Scientist, Central Institute of Agricultural Engineering (ICAR), Nabi Bagh, Berasia Road, Bhopal - 462 038, India; A. K. Dave, Assistant Professor, Faculty of Agricultural Engineering, IGKV Raipur, India; B. G. Yadav, Senior Research Fellows and Principal Scientist, Central Institute of Agricultural Engineering (ICAR), Nabi Bagh, Berasia Road, Bhopal - 462 038, India.

Planting of dry seeds of paddy in puddle is feasible. The pneumatic seed-metering concept is based upon the air pressure developed on the inner surface of rotating cylindrical drum. One end of the seed tube(s) are fixed to the seed cups placed near top dead center and another

end is open to the atmosphere in the furrow opener. The seed dropped in the tube at the interaction region of high and low pressure. The desired planting was achieved at injecting pressure of 1,300-1,350 N/m² and operating speed ranges from 0.228-0.338 m/s when the depth of seed placement was between 0.76-0.77 cm in puddle.

391

Apparent Viscosity of Formulations of Inulin Chicory Extract (*Cichorium intybus* L) with Modified and Hydrolyzed Starches: R. I. Nogueira, EMBRAPA Food Technology, Brazil; K. J. Park, UNICAMP/FEAGRI, Cx. P 6011, 13083-970, Campinas SP, Brazil; E. Deyrmendjian, same; R. E. Bruns, UNICAMP/IQ, Brazil; J. Bortoloti, same.

Rheological properties of chicory root extracts were determined at 25 °C, 40 °C and 55 °C. Samples consisted of pure concentrated extract and concentrated extract formulated with hydrolyzed and modified starch. All suspensions exhibited a pseudoplastic behavior, with an index value (n) varying from 0.42 to 0.97 in the shear rate range of 14 to 264 s⁻¹. Statistical models indicate that the apparent viscosity of suspensions, formulated with the two different starches, are affected principally by the proportion of hydrolyzed starch, the proportion of modified starch and the fraction of the two starches in the total mixture.

396

Ergonomical Problems Associated with Agricultural Operations in Tamil Nadu a Case Study: K. Kathirvel, Professor and Head, Agricultural Engineering College and Research Institute, TNAU, Coimbatore - 641 003, India; R. Manian, Dean, same; T. Senthilkumar, Ph. D Scholar, same.

With the introduction of modern technology, ergonomics become essential for its successful application. The important point here is that the major benefit to the agriculture is to have safe, healthy and productivity worker. Poorly designed equipment or implements or products often require worker/users to compensate or exert themselves unnecessarily. Too often such over exertion lead to both job related errors and an increased level of risk – and then the stressors transmit the stress onto the workers directly reducing their ability to do their job safely and effectively. Twelve villages (including hilly region) were selected from seven agro climatic regions of Tamil Nadu State such that they use agricultural machinery extensively for various operations in crop production and processing activities to study ergonomics problem in agricultural machinery operation. Based on the survey results, the mean ergonomics score was computed and the farming operations carried by female and male farm workers. The operations which call for ergonomic intervention for reducing drudgery and health risk of female farm workers are ranked as harvesting by sickle - 121.5 (1), weeding by hand hoe - 91.1 (2), paddy transplanting - 52.3 (3) and tea leaf picking - 12.3 (4). The farming operations carried

by male farm workers are ranked as sugar cane stubble removal - 76.2 (1), harvesting root crop - 49.8 (2), spraying by knapsack sprayer - 30.0 (3), digging by spade/pick axe - 24.8 (4) and tractor driving - 22.3 (5). The drudgery involved in the above operations may be reduced by incorporating improvement in machine/tool design.

404

Effect of Adhesives on the Durability Index of Compacted Olive Cake: Hamid Al-Jalil, Associate Professor, Department of Biosystems Engineering, Faculty of Engineering, Jordan University of Science and Technology, P.O. Box 3030, Irbid 22110, Jordan; Mohamad Al-Widyan, Associate Professor, same; Fatma Al-Widyan, Undergraduate Student, same.

Generally, briquettes of plain olive cake, OC, lack durability. This work involved mixing OC at 35 % moisture with 1 to 4 % of wood adhesive or clay loam and compacting the mixture at a stress of 15 to 45 MPa and dwell time of 5 s. An ASAE standard tumbler was used to determine the briquette durability. The results showed that adhesives had substantial effect and increased the durability index by more than 11 times compared to plain OC. Overall, clay loam, was the favorable adhesive and when added at 2 % and compared at 35 MPa produced the best desirable outcome.

409

Influence of Engine Regime and Cabin Condition on Noise Level in Agricultural Tractors: J. A. Hilbert, Ingeniero Agrónomo M.Sc. Instituto de Ingeniería Rural CNIA INTA-c.c. 25 (1712) Castelar, Argentina; M. Borini, Facultad de Agronomía Universidad de Buenos Aires, Argentina; H. Centrangolo, Cátedra de seminario de campo III Facultad de Agronomía Universidad de Buenos Aires, Argentina; A. Amador, same.

At the present state of the economic reality with the priority given to overall efficiency, reduction of production costs and transformation of farms human factors is becoming an important issue. The sound exposure levels has a direct relation with human health and productivity at work. To study the sound level exposure influence on tractors drivers in tractor cabs, five tractors with different power, model were employed under normal field work with different machines. The measurement of sound level was made using sound level meter CEL-480 at the operator's ear level following IRAM 4119/1 standard in A weighting. A broad band and spectral frequency analysis, octave and one-third octave was performed. Variables include opening of the doors and different engine regimes. According to the results a comparison with NCB (Beranek, 1989) and ISO1999 (1975) was made. Significant differences according to the doors situation and engine speed were detected.



Agritechnica 2007 starts

World's leading exhibition for agricultural machinery in Hanover from 13 to 17 November 2007 - Closing date for registration is 1 February 2007

(DLG). With the mailing of the stand registration papers to exhibitors, preparations for the international DLG exhibition for agricultural machinery, Agritechnica 2007, are now entering a key phase. The world's leading exhibition for agricultural machinery will be presented to the international public at the exhibition grounds in Hanover from 13 to 17 November 2007. The organiser DLG (Deutsche Landwirtschafts-Gesellschaft - German Agricultural Society) has once again scheduled two Preview Days on 11 and 12 November 2007. The closing date for registrations for exhibitors is 1 February 2007.

Of all the agricultural machinery exhibitions, Agritechnica is the one with the highest proportion of manufacturers and authorised importers among the exhibitors. All the agricultural machinery companies operating worldwide and throughout Europe are represented directly here. They offer altogether the most comprehensive and varied exhibition programme for arable farming and plant production. More than 1,600 companies from all over the world took part in the last event in 2005. The exhibition date in November is particularly attractive. This is where manufacturers present their innovations to their partners in distribution and to practical farmers, and where farmers plan their investments for the coming season. With almost 260,000 visitors, including 44,000 from abroad, Agritechnica 2005 exerted a strong power of attraction on private contractors, machine rings and farmers from all over the world. Agricultural machinery dealers and the trade see Agritechnica as their forum and make special use of the Preview Days. Agritechnica will be the communications bourse for the global agricultural branch in 2007 too.

Complete Exhibition Programme

The complete exhibition programme of Agritechnica 2007 will be presented in modern, ground-level halls at the world's

largest exhibition grounds in Hanover. Covering more than 20 ha of exhibition floor space, Agritechnica comprises the following sections:

- Machinery and equipment for soil cultivation, sowing, fertilising, sprinkling and irrigation
- Plant protection and plant care
- Harvesting machinery and equipment for forage crops, grain, root crops, maize
- Harvest processing and conditioning
- Tractors, transport vehicles, conveyor technology
- Renewable energy and bioenergy sources, renewable industrial raw materials
- Machinery and equipment for forestry work, municipal applications, landscape care
- Field vegetable growing, organic farming
- Machinery and equipment for fruit farming, viticulture and special crops
- Farm inputs (biotechnology/seed, fertilising, plant protection, fuels and lubricants)
- Electronics, agricultural software, Precision Farming
- Components, drive engineering, spare parts, accessories
- Services for marketing used machinery and equipment
- Management, information, science and research

New: Soil Cultivation Worldwide - Concepts and Solution

In 2007 special attention will be devoted to the thematic area "soil and soil cultivation" for the first time at Agritechnica. In this "World Soil and Tillage Show", the current challenges for soil working in various regions of the world are to be presented as a joint project by the fields of academia, consultants, practical farming and the agricultural machinery industry. Optimal seedbed preparation, or problem complexes such as soil erosion, soil compaction and soil fertility in damp or dry regions in Central and Eastern Europe, North and South America, all call for specific solutions. The "World Soil and Tillage Show" will supply global ideas and visions through site-appropriate solutions: successful machinery and management

systems, examples of best practice in soil cultivation, and experience gained by the world's best farmers will be shown and presented there. Trial fields, demonstrations and technical details from leading enterprises will all contribute to ensuring that there is a comprehensive programme. Climate change will be a topic in focus too. It will be shown clearly how the climatic changes are influencing soil and soil cultivation. The "World Soil and Tillage Show" will thus provide farmers with extremely interesting working strategies for their forthcoming investments.

New: Special 'Workshop LIVE'

Good provision of services and optimally trained specialists are a key prerequisite for the agricultural machinery market to function properly. In cooperation with the Main Association of German Agricultural Machinery Dealers and Craft Trades, the requirements made of mechanics for agricultural and construction machinery technology will be shown in an Agritechnica Special "Workshop LIVE", looking at practical hands-on demonstrations of repair, maintenance and conversion work with expert commentaries.

Innovations and Concepts for Solutions to all Aspects of Bioenergy

The dynamic and highly interesting developments in the area of renewable energies and renewable raw materials are providing almost the entire agricultural machinery branch with opportunities to present innovations and solution concepts to questions of production, processing and logistics. That is why even more space will be devoted to questions concerning all aspects of bioenergy at Agritechnica 2007, and it will be a theme on many exhibition stands. This will be supplemented by a rich programme with technical lectures from industry, academia, consultants and practical farmers. Furthermore, solutions from specialists from the entire field of bioenergy will be shown, pooled in a "Bioenergy Center". Agritechnica is thus underlining its function as a unique forum of the future for the international agricultural sector. It is not only an innovations platform for the latest in mod-

ern machinery and equipment, but also an ideas tank and an impetus provider for answers to the key future questions concerning agro-economics and agricultural machinery.

Top-flight International Technical Programme

A top-flight side programme with a wide number of international events will complement the machinery and equipment programme presented by the exhibitors. For instance, within the context of Agritechnica 2007 conferences

such as the International Agricultural Machinery Congress of VDI/MEG, the second European Wheat Event, an international Seed Congress and an Eastern Europe Congress on Agricultural Machinery will be held. Furthermore, the European Young Farmers' and Students' Conference organised jointly by "Young DLG" and European universities for Agritechnica 2007 will attract a great deal of attention. A widely varied technical programme will also be provided in special forums with international orientation, in a large number of different

languages.

For further information on Agritechnica 2007 please contact the DLG, Eschborner Landstr. 122, D-60489 Frankfurt am Main, Tel. +49/69/24788-252 or -255, Fax:+49/69/24788-113 or e-mail a.schmidt@dlg.org. Information about Agritechnica 2007 is also available on the Internet at www.agritechnica.com. ■■

New-Publications from ASABE

Design in Agricultural Engineering

Detailed Description:

This textbook covers defining the creative problem, scheduling design activity, estimating costs, considering safety and ethics in design, standardizing for manufacturing considerations, testing and evaluation, understanding business and organization structures, selling the company or marketplace on ideas, arranging for patents, trademarks and copyrights, respecting trade secrets, and working with engineering and non-engineering colleagues, 312 pages, 1986, 6 x 9 inches, softbound.

ISBN: 0-916150-80-1

Order No. M1086

Member \$36.25 /List \$41.25

"Problem Solving with Excel"

Author(s):

Dennis R. Buckmaster P.E., Purdue University

Detailed Description:

This 70-minute training video on CD-ROM will show you how to make engineering problem solving more effective, less time consuming, and easier to communicate to others. Through video,

audio and watching the actual steps on example spreadsheets the user can build skills in working with:

- labels in formulas
- data filtering
- optimization
- goal seeking for iterative solutions
- data tables
- lookup functions
- macros/forms

This CD-ROM will help engineers and other problems solvers follow a logical format and approach when using Excel spreadsheets to solve engineering problems. The video package, produced by Purdue professor Dennis Buckmaster, grew out of his workshop experiences with students, faculty, and practicing engineers. The presentation assumes the user is familiar with basic spreadsheet skills such as formula editing, graphing, and formatting. In addition to being a training video, the package serves as valuable reference.

Biological Engineering Volume 1, Number 1 February 2007

Purpose and Scope:

This journal focuses on a wide range of biological engineering topics including bioprocessing, bioreactor design,

cell culture, tissue engineering, metabolic engineering, biosensors, bioinstrumentation, bioenvironmental systems, ecological engineering, bioremediation, modeling of biological processes, molecular technologies, bioconversion, biological structures and mechanics, biofuels, and more.

2007 Volume No. 1

Number of Issues per Year: 4

ISSN: 1934-2799

6 x 9 inches

Indexing and Abstracting:

Biological Engineering will be indexed and abstracted in AGRICOLA and CAB International Abstracts. Others will ■■

Co-operating Editors



B Kayombo



M F Fonteh



A A K
El Behery



A M
El Hossary



B S Pathak



R J Bani



I K Djokoto



D K Some



K Hourmy



J C Igbeka



E U-Odigboh



K C Oni



N G
Kuyembeh



A H
Abdoun



A B Saeed



A I Khatibu



E A Baryeh



S Tembo



H A
Cetrangolo



I de A Nääs

-AFRICA-

Benedict Kayombo

Associate Professor of Soil and Water Engineering, Dept. of Agric. Engineering and Land Planning, Botswana College of Agriculture, University of Botswana, Private Bag 0027, Gaborone, BOTSWANA. TEL(+267)-3650125, FAX(+267)-328753 E-mail: bkayombo@bca.bw

Mathias Fru Fonteh

Asst. Professor and Head, Dept. of Agric. Engineering, Faculty of Agriculture, University of Dschang, P.O. Box 447, Dschang, West Province, CAMEROON TEL+237-45-1701/1994, FAX+237-45-2173/1932 E-mail: m.f.fonteh@camnet.cm

Ahmed Abdel Khalek El Behery

Agric Engineering Research Institute, Agricultural Reserch Center, Nadi El-Said St. P.O. Box 256, Dokki 12311, Giza, EGYPT

Ali Mahmoud El Hossary

Senior Advisor to the Ministry of Agriculture and Chairman of (AGES)-Agengineering Consulting Group, Ministry of Agriculture - P.O.Box 195 Zama- lek 11211 Cairo, EGYPT TEL00-202-335-9304, FAX00-202-3494-132

B.S. Pathak

Project Manager, Agric. Implements Research and Improvement Centre, Melkassa, ETHIOPIA

Richard Jinks Bani

Lecturer & Co-ordinator, Agric. Engineering Div., Faculty of Agriculture, University of Ghana, Legon, GHANA

Israel Kofi Djokoto

Senior Lecturer, University of Science and Technol- ogy, Kumasi, GHANA

David Kimutaiarap Some

Professor, Deputy Vice-chancellor. Moi University, P.O. Box: 2405, Eldoret, KENYA

Karim Houmy

Professor and head of the Farm Mechanization Dept., Institute of Agronomy and Velerinary Medi- cine II, Secteur 13 Immeuble 2 Hay Riad, Rabat, MOROCCO, Tel+212-7-68-05-12, Fax+212-7-775801 E-mail: houmy@maghrebnet.net.ma

Joseph Chukwugotium Igbeka

Professor, Dept. of Agricultural Engineering, Univ. of Ibadan,, Ibadan, NIGERIA TEL+234-2-8101100-4, FAX+234-281030118 E-mail: Library@ibadan.ac.ng

E.U, Odigboh

Professor, Agricultural Engg Dept., Faculty of En- gineering, University of Nigeria, Nsukka, Enugu state, NIGERIA, TEL+234-042-771676, FAX042- 770644/771550, E-mail: MISUNN@aol.com

Kayode C. Oni

Director/Chief Executive, National Centre for Agric. Mechanization (NCAM), P.M.B.1525, Ilorin, Kwara State, NIGERIA TEL+234-031-224831, FAX+234-031-226257 E-mail: ncam@skannet.com

N.G. Kuyembeh

Associate Professor, Njala University Colle, Univer- sity of Sierra Leone, Private Mail Bag, Free Town, SIERRA LEONE TEL+249-778620-780045, FAX+249-11-771779

Abdien Hassan Abdoun

Member of Board, Amin Enterprises Ltd., P.O. Box 1333, Khartoum, SUDAN

Amir Bakheit Saeed

Assoc. Professor, Dept. of Agric. Engineering, Fac- ulty of Agriculture, University of Khartoum, 310131 Shambat, SUDAN, TEL+249-11-310131

Abdisalam I. Khatibu

National Prolect Coordinafor and Direcror, FAO Ir- rigated Rice Production, Zanzibar, TANZANIA

Edward A. Baryeh

Professor, Africa University, P.O.Box 1320, Mutare, ZIMBABWE

Solomon Tembo

52 Goodrington Drive, PO Mabelreign,Sunridge, Harare, ZIMBABWE

-AMERICAS-

Hugo Alfredo Cetrangolo

Full Professor and Director of Food and Agribusi- ness Program Agronomy College Buenos Aires University, Av. San Martin4453, (1417) Capital Fed-

eral, ARGENTINA

TEL+54-11-4524-8041/93, FAX+54-11-4514-8737/39 E-mail: cetrango@agro.uba.ar

Irenilza de Alencar Nääs

Professor, Agricultural Engineering College, UNI- CAMP, Agricultural Construction Dept.,P.O. Box 6011, 13081 -Campinas- S.P.,BRAZIL TEL+55-19-7881039, FAX+55-19-7881010 E-mail: irenilza@agr.unicamp.br

A.E. Ghaly

Professor, Biological Engineering Department Dalhousie University, P.O. Box 1000, Halifax, Nova Scotia, B3J2X4, CANADA TEL+1-902-494-6014, FAX+1-902-423-2423 E-mail: abdel.gahaly@dal.ca

Edmundo J. Hetz

Professor, Dept. of Agric. Eng. Univ. of Concepcion, Av. V.Mendez 595, P.O. Box 537, Chillan, CHILE TEL+56-42-216333, FAX+56-42-275303 E-mail: ehetz@udec.cl

A.A. Valenzuela

Emeritus Professor, Ag. Eng. Fac., University of Concepcion,Casilla537Chillan, CHILE TEL+56-42-223613, FAX+56-42-221167

Roberto Aguirre

Associate Professor, National University of Colom- bia, A.A. 237, Palmira, COLOMBIA TEL+57-572-2717000, FAX+57-572-2714235 E-mail: ra@palmira.unal.edu.co

Omar Ulloa-Torres

Professor, Escuela de Agricultura de la Region, Tropical Humeda(EARTH), Apdo. 4442- 1000, San Jose, COSTA RICA, TEL+506-255-2000, FAX +506-255-2726, E-mail: o-ulloa@ns.earth.ac.cr

S.G. Campos Magana

Leader of Agric. Engineering Dept. of the Gulf of Mexico Region of the National Institute of Forestry and Agricultural Research, Apdo. Postal 429. Vera- cruz, Ver. MEXICO

Hipolito Ortiz-Laurel

Head of Agric. Engineering and Mechanization Dept./ Postgraduate College, Iturbide 73, Salinas de Hgo, S.L.P., C.P. 78600, MEXICO TEL+52-496-30448, FAX+52-496-30240



A E Ghaly



E J Hetz



A A
Valenzuela



R Aguirre



O Ulloa-Torres



S G C
Magana



H Ortiz-Laurel



W J
Chancellor



M R Goyal



A K
Mahapatra



G R Quick



S M Farouk



Daoulat
Hussain



M A Mazed



Chetem
Wangchen



Wang
Wanjun



S Illangantileke



S M Ilyas



A M Michael



G Singh



T P Ojha



S R Verma



Soedjatmiko



M Behrooz-
Lar



Saeid
Minaei



J Sakai



B A Snobar



C J Chung



C C Lee



M Z
Bardaie

William J. Chancellor

Professor Emeritus, Bio. and Agr. Eng. Dept., Univ. of California, Davis, CA, 95616, U.S.A.
TEL+1-530-753-4292, FAX+1-530-752-2640
E-mail: wjchancellor@ucdavis.edu

Megh R. Goyal

Prof./Agric & Biomedical Engineering, University of Puerto Rico, P.O.Box 5984, Mayaguez PR, 006815984, U.S.A., TEL+1-787-265-4702
E-mail: m_goyal@ece.uprm.edu

Ajit K. Mahapatra

Present add: Agric. & Biosystems Eng. Dept., South Dakota State Univ., P.O. Box 2120 Brookings, SD 57007-1496, U.S.A., TEL605-6885291, FAX 605-6886764, E-mail: mahapata@sdstate.edu

-ASIA and OCEANIA-

Graeme R. Quick

Consulting Engineer, 83 Morrisons Road, Peaches-ter, Queensland, 4519, AUSTRALIA

Shah M. Farouk

Professor (Retd.), Farm Power & Machinery Dept., Bangladesh Agricultural University, Mymensingh 2200, BANGLADESH, TEL+880-91-5695ext.2596, FAX91-55810, E-mail: smf@bdcom.com

Daulat Hussain

Dean, Faculty of Agric. Engineering and Technology, Bangladesh Agricultural University, Mymensingh-2202, BANGLADESH, TEL+880-91-52245, FAX91-55810, E-mail: dhussain@royalten.net

Mohammed A. Mazed

Member-Director, Bangladesh Agri. Res. Council, Farmgate, Dhaka, BANGLADESH
E-mail: mamazed@barcbgd.org

Chetem Wangchen

Programme Director Agricultural Machinery Centre Ministry of Agriculture Royal Government of Bhutan, Bondey Paro Bhutan 1228, BHUTAN, E-mail: krtamc@druknet.bt

Wang Wanjun

Past Vice Director and Chief Engineer/Chinese Academy of Agricultural Mechanization Sciences, 1 Beishatan, Beijing, 100083, CHINA
TEL+86-(0)83-001-6488-2710, FAX001-6488-2710
E-mail: wwj@isp.caams.org.cn

Sarath Illangantileke

Regional Representative for South and West

Asia, International Potato Center (CIP), Regional Office for CIP-South & West Asia, IARI (Indian Agric. Res. Institute) Campus, Pusa, New Delhi-12, 110002, INDIA, TEL+91-11-5719601/5731481, FAX./5731481, E-mail: cip-delhi@cgjar.org

S.M. Ilyas

Director of Central Institute of Post Harvest Engineering and Technology (CIPHET), Ludhiana. P.O., P.A.U, Ludhiana - 121004, INDIA, TEL+91-161-808669, Fax:+91-161-808670, E-mail: ciphet@satyam.net.in

A.M. Michael

1/64, Vattekkunnam, Methanam Road, Edappally North P.O., Cochin, 682024, Kerala State, S. INDIA

Gajendra Singh

Professor, Vice Chancellor, Doon University 388/2, India Nagar, Dehradun - 248006, INDIA
TEL+91-989-738-4111, FAX+91-135-320-1920
Email: gajendrashinghb@gmail.com

T.P. Ojha

Director General(Engg.) Retd., ICAR, 110, Vineet Kung Akbarpur, Kolar Road, Bhopal, 462 023, INDIA
TEL+91-755-290045

S.R. Verma

Prof. of Agr. Eng. & Dean Eng.(Retd), 14, Good Friends Colony, Barewal Road, Via Ayoli Kalan, Ludhiana 142027 Punjab, INDIA, TEL+91-(0)161-463096
E-mail: srverma@hotmail.com

Soedjatmiko

President, MMAI(Indonesian Soc. of Agric. Eng. & Agroindustry), Menara Kadin Indonesia Lt.29 Jl. HR. Rasuna Said X-5/2-3 Jakarta, 12940, INDONESIA
TEL+62-(0)21-9168137/7560544, FAX(0)21-527448 5/5274486/7561109

Mansoor Behrooz-Lar

Professor, Agr. Machinery, Ph.D, Tehran University Faculty of Agriculture, Karaj, IRAN
TEL+98-21-8259240, E-mail: mblar@chmran.ut.ac.ir

Saeid Minaei

Assistant Professor, Dept. of Agr. Machinery Eng., Tarbiat Modarres Univ., P.O.Box 14115-111, Tehran, IRAN
TEL+9821-6026522-3(office ext.2060, lab ext.2168)
FAX+9821-6026524, E-mail: minaee7@hotmail.com

Jun Sakai

Professor Emeritus, Kyushu University, 2-31-1 Chihaya, Higashi-ku, Fukuoka city, 813, JAPAN
TEL+81-92-672-2929, FAX+81-92-672-2929
E-mail: junsakai@mtj.biglobe.ne.jp

Bassam A. Snobar

Professor and Vice President, Jordan University of Science and Technology, P.O.Box 3030 Irbid, 22110, JORDAN, TEL+962-2-295111, FAX+962-2-295123
E-mail: snobar@just.edu.jo

Chang Joo Chung

Emeritus Professor, Seoul National University, Agricultural Engineering Department, College of Agriculture and Life Sciences, Suwon, 441-744, KOREA
TEL+82-(0)331-291-8131, FAX+82-(0)331-297-7478
E-mail: chchung@hanmail.net

Chul Choo Lee

Mailing Address: Rm. 514 Hyundate Goldentel Bld. 76-3 Kwang Jin Ku, Seoul, KOREA
TEL+82-(0)2-446-3473, FAX+82-(0)2-446-3473
E-mail: ccsllee@chollian.net

Muhamad Zohadie Bardaie

Professor, Department of Agricultural and Biosystems Engineering, University Putra Malaysia, 43400 upm, Serdang, Serdangor, MALAYSIA
TEL+60-3-89466410
Email: zohadie@eng.upm.edu.my

Madan P. Pariyar

Consultant, Rural Development through Selfhelp Promotion Lamjung Project, German Technical Cooperation. P.O. Box 1457, Kathmandu, NEPAL

David Boakye Ampratwum

Associate Professor, Dept. of Bioresource and Agricultural Engineering, College of Agriculture, Sultan Qaboos University, P.O. Box 34, Post Code 123, Muscat, Sultanate of Oman, OMAN
TEL+968-513866, FAX513866
E-mail: davidamp@squ.edu.om

EITag Seif Eldin

Mailing Address: Dept. of Agric. Mechanization, College of Agriculture, P.O. Box 32484, Al-Khod, Sultan Qaboos University, Muscat, Sultanate of Oman, OMAN

Linus U. Opera

Associate Professor, Agricultural Engineering & Postharvest technology, Director, Agricultural Experiment Station, Sultan Qaboos University, Muscat, Sultanate of Oman, OMAN

Allah Ditta Chaudhry

Professor and Dean Faculty of Agric. Engineering and Technology, University of Agriculture, Faisalabad, PAKISTAN



M P Pariyar



D B
Ampratwum



E S Eldin



L U Opera



A D
Chaudhry



A Q Mughal



R ur Rehmen



B T
Devrajani



N A
Abu-Khalaf



Surya Nath



R M Lantin



R P Venturina



S A Al-Suhaibani



A M S Al-Amri



S F Chang



T S Peng



S Krishnasreni



S Phongsupasamit



C Rojanasaroj



V M Salokhe



Y Pinar



I Haffar



N Hay



P V Lang



A A Hazza'a



A P Kaloyanov



P Kic



H Have



G Pellizzi



A A Wanders

A.Q.A. Mughal

Vice Chancellor, Sindh Agriculture University, Tandojam, PAKISTAN

Rafiq ur Rehman

Director, Agricultural Mechanization Reserch Institute, P.O. Box No. 416 Multan, PAKISTAN

Bherulal T. Devrajani

Professor and Chairman, Faculty of Agricultural Engineering, Sindh Agriculture University, Tandojam, Sindh, PAKISTAN
TEL+92-2233-5594

Nawaf A. Abu-Khalaf

Engineer, the Project Directorate in Palestinian Agricultural Ministry, P.O.Box 405, Hebron, PALESTINE
Telfax: 972-2-2227846/7
E-mail: nawafu@hotmail.com

Surya Nath

Assoc. Prof., Dept. of Agriculture, Papua New Guinea University of Technology, Private Mail Basg, Lae, PAPUA NEW GUINEA, TEL+675-475-5162, FAX473-4477, E-mail: Nath@datec.net.pg

Reynaldo M. Lantin

Professor, College of Engineering and Agro-Industrial Technology University of the Philippines Los Banos, Laguna 4031, PHILIPPINES
TEL+63-(0)49-536-2792, FAX+63-(0)49-536-2873
E-mail: rmlantin@emudspring.uplb.edu.ph

Ricardo P. Venturina

President & General Manager, Rivelisa publishing House, 215 F, Angeles St. cor Taft Ave. Ext., 1300 Pasay City, Metro Manila, PHILIPPINES

Saleh Abdulrahman Al-suhaibani

Professor, Agricultural Engineering Dept., College of Agriculture, King Saud University, P.O. Box 2460 Riyadh 11451, SAUDI ARABIA

Ali Mufarreh Saleh Al-Amri

Professor, Dept. of Agric. Engineering, Colleg of Agricultural and Food Sciences, King Faisal University, Al-Ahsa, SAUDI ARABIA
E-Mail: aamri@kfu.edu.sa, aamri2020@yahoo.com

Sen-Fuh Chang

Professor, Agric.-Machinery Dept. National Taiwan University, Taipei, TAIWAN

Tieng-song Peng

Deputy Director, Taiwan Agricultural Mechanization Research and Development Center. FL. 9-6, No. 391 Sinyi Road, Sec. 4, TAIWAN

Suraweth Krishnasreni

Senior Expert in Agricultural Engineering, Department of Agriculture, Chatuchak, Bangkok 10900, Thailand, Tel5792153, 5794497, 5798520, Ext.124, Fax9405791, E-mail: Suraweth@doa.go.th

Surin Phongsupasamit

Professor of Agricultural Engineering, Dept. of Mechanical Engineering, Faculty of Engineering, Chulalongkorn University, Phyathai Road, Patumwan, Bangkok 10330, THAILAND

Chanchai Rojanasaroj

Research and Development Engineer, Dept. of Agriculture, Ministry of Agriculture and Cooperatives, Gang-Khen, Bangkok 10900, THAILAND

Vilas M. Salokhe

Professor, AFE Program, Asian Institute of Technology, P.O. Box 4, Klang Luang. Pathumthani 12120, THAILAND, TEL+66-2-5245479, FAX+66-2-5246200
E-mail: salokhe@ait.ac.th

Yunus Pinar

Professor, and Head, Agric. Machinery Dept, Faculty of Agriculture, University of Ondokuz Mayıs, Kurupelit, Samsun, TURKEY

Imad Haffar

Associate Professor of Agric. Engineering, Faculty of Agricultural Sciences, United Arab Emirates University, Al Ain, P.O. Box 17555, UAE
TEL+971-506436385, FAX+971-3-632384
E-mail: haffar96@emirates.net.ae

Nguyen Hay

Associate Professor, Dean of Faculty of Engineering, Nonglam University, Linh Trung Ward, Thu Duc District, Ho Chi Minh City, VIET NAM
E-mail: nguyenhay@hcm.fpt.vn

Pham Van Lang

Director, Vietnam Institute of Agricultural Engineering, A2-Phuong Mai, Dong Da Hanoi, VIET NAM

Abdulsamad Abdulmalik Hazza'a

Professor and Head of Agricultural Engineering Department, Faculty of Agriculture, Sana'a University, P.O.Box 12355, Sana'a YEMEN
Tel+9671-407300, Fax:9671-217711
E-mail: hazaia@yahoo.com

-EUROPE-

Anastas Petrov Kaloyanov

Professor & Head, Research Laboratory of Farm

Mechanization, Higher Institute of Economics, Sofia, BULGARIA

Pavel Kic

Vice-Dean/Technical Faculty, Czech University of Agriculture Prague, 16521 Prague 6-Suchdol, CZECH, Tel+420-2-24383141, Fax+420-2-20921361
Email: KIC@TF.CZU.CZ

Henrik Have

Prof. of Agric. Machinery and Mechanization at Institute of Agric. Engineering, Royal Veterinar/- and Agricultural University, Agrovej 10DK2630 Tastrup, DENMARK

Giuseppe Pellizzi

Director of the Institute of Agric. Engineering of the University of Milano and Professor of Agric. Machinery and Mechanization, Via G. Celoria, 2-20133 Milano, ITALY
Tel+39-02-503-16871, Fax+39-02-503-168459
E-mail: giuseppe.pellizzi@Unimi.it

Aalbert Anne Wanders

Staff Member, Dept. of Development Cooperation, Netherlands Agricultural Engineering Research Institute (IMAG), Wageningen, NETHERLANDS

Jan Pawlak

Professor, head of the Dept. of Economics and Utilization of Farm Machines at IBMER, Professor at the Univ. of Warmia and Mazury in Olsztyn, Fac. of Tech. Sci., POLAND

Oleg S. Marchenko

Professor and agricultural engineer, Department Head in All-Russia Research Institute for Mechanization in Agriculture (VIM), 1st Institutsky proezd, 5, Moscow 109428, RUSSIA
Tel+7(095)174-8700, Fax+7(095)171-4349
E-mail: oleg072000@mail.ru

John Kilgour

Senior Lecturer in Farm Machinery Design at Silsoe College, Silsoe Campus, Silsoe, Bedford, MK45 4DT, UK

Milan Martinov

Full Professor on Agricultural Machinery, University of Novi Sad, Faculty of Engineering, Institute of mechanization and machine design, TRG D. Obradovica 6, 21 121 Novi Sad, PF55, YUGOSLAVIA
TEL+381-21-350-122(loc.298), FAX+381-21-350-592
E-mail: mmartog@uns.ns.ac.yu



Jan Pawlak



O S Marchenko



J Kilgour



M Martinov

Back Issues

(Vol.35, No.2, Spring, 2004-)

AGRICULTURAL MECHANIZATION IN ASIA, AFRICA AND LATIN AMERICA (Vol.35, No.2, Spring, 2004)

On-Farm Evaluation of Current Wheat Tillage Systems on Irrigated Vertisols in New Scheme, Sudan (Sheikh El-Din Abdel Gadir El-Awad)	9
Development and Testing of a Seed-Cum-Fertilizer Drilling Attachment to Tractor-Driven Cultivator (R. A. Gupta, Paramond Mohnot, R. M. Satsiya, R. B. Marvia)	15
Development and Evaluation of Weeding Cum Earthing up Equipment for Cotton (R. Manian, K. Kathirvel, Aravinda Reddy, T.Senthikuamr).....	21
Design Parameters for Cocoa Pod Breaker (A Issac Bamgboye, Odima-Ojoh)	26
A Solar Tunnel Dryer for Natural Convection Drying of Vegetables and Other Commodities in Cameroon (Joseph E. Berinyuy)	31
Rural Vegetable Oil Processing in Kenya Status and Reseach Priorities (D. Shitanda)	36
Design and Development of Agricultural Wastes Shredder (J. B. Savani, V. R. Vagadia, R. K. Kathiria).....	41
Dynamometer Design for Traction Forces Measurement on Draught Horses (H. Ortiz-laurel, P. A. Cowell)	47
Reduction of Greenhouse Temperature Using Reflector Sheet (V. P. Seth, Y. P. Gupta, V. S. Hans).....	51
Farm Accidents in South India: A Critical Analysis (K. Kathirvel, R. Manian, D. Ananathakrishnan, T. Senthikumar)	55
Present Status and Future Strategy on Farm Mechanization and Postharvest Technologies for Rice Production and Processing in Bangladesh (Sydul Islam, Abdul Baqui, M. Abul Quasem).....	59
Mechanization of Polish Agriculture in the Transition Period (Jan Pawlak).....	67



AGRICULTURAL MECHANIZATION IN ASIA, AFRICA AND LATIN AMERICA (Vol.36, No.1, Spring, 2005)

Para-Plothing Effect on Soil Retention (P. R. Jayan, C. Divaker Durairaj, V. F. J. Kumar)9	9
Effect of Storage Conditions on Emergence of Helthy Seeding of Soyabean (G. H. Jamro, L. A. Jamali, M. hatim, S. K. Agha).....	15
Development of a Check Valve Mechanism as an Attachment to a Power Tiller Operated Seeder (D. Dhalin, C. Divaker Durairaj, V. F. J. Kumar).....	18
Freely Rear Converging Linkage System for No-Till Planter (Santos G. Campos Magna, Brian M. D. Wills).....	24
Fablication and Performance Evaluation of Pre-Rasping Unit for Cassava Industries (R. Kailappan, S. Kaleemullah, I. P. Sudagar, C. T. Devadas, M. Jawaharlal)	33
Agricultural Tractor Ownership and Off-Season Utilisation in the Kgatlang District of Botsuwana (Cecil Patric, Edward A.	

Bayeh, Mataba Tapela).....	41
Tillage Systems and Their Effect on Some Soil Properties, Crop Growth and Shoot Yield of Grain-Amaranth (S. O. Afolayan, J. C. Igbeka, O. Babalola).....	46
Effect of Concave Hole Size, Concave Clearance and Drum Speed on Rasp-Bar Drum Performance for Threshing Sunflower (Somposh Sudajan, Vilas M. Salokhe, Somnuk Chusilp).....	52
Performance Evaluation of Planters for Cotton Crop (K. Kathirvel, Aravinda Reddy, R. Manian, T. Senthikuamr).....	61
Spatial Distribution of the No-Till Opener Induce Seed Row Incorporated Crop Residue and Soil Loosing (E. M. H. Tola, K. Koeller)	66
Farm Mechanization in Lalgudi Taluk of Southern India (S. Ganapathy, R. Karunanithi)	71
Comparative Evaluation of Field Performance of a Tractor Drawn Straw Reaper and a Flail Harvesting of Wheat Straw.....	76
Study on the Development of Agricultural Machines for Small-Scale Farmers "Pt. 1, Applied Technology for Morocco and Africa" (Toshiyuki Tsujimoto, Hai Sakurai, Koichi Hashiguchi, Eiji Inoue).....	79



AGRICULTURAL MECHANIZATION IN ASIA, AFRICA AND LATIN AMERICA (Vol.36, No.2, Autumn, 2005)

A Mathematical Model for Predicting Output Capacity of Selected Stationary Grain Threshers (V. I. O. Ndirika).....	9
Study on the Development of Agricultural Machines for Small-Scale Farmers Pt. 2, "Applied Technology to the Improvement of an Animal-Drawn Plow for Morocco and Africa" (Toshiyuki Tsujimoto, Hai Sakurai, Koichi Hashiguchi, Eiji Inoue).....	14
Development an Indsutrial Yam Peeler (A. C. Ukatu)	21
Design and Development of a Low-Cost Potato Grader (K. C. Roy, M. A. Wohab, A. D. M. Gulam Mustafa)	28
Extensive Review of Crop Drying and Drivers Developed in India (A. Alam, Harpal Singh, Ranjan Mohnot, H. L. Kushwaha)....	32
Insect Inhibitive Properties of Some Consumable Local Plant Materials on Grains in Storage (D. S. Zibokere).....	43
Evaluation and Performance of Raw Mango Grader (Syed Zameer Hussain, S. C. Mandhar, S. Javare Gowda).....	46
Engineering the Crop Establishment System for Paddy Wet Seeding (Eden C. Gage-lonia, B. D. Tadeo, E. G. Bautista, J. C. Cordero, J. A. Damian, W. B. Collado, H. Monobe, S. Ishihara, N. Sawamura, M. Daikoku, R. Otani).....	49
Performance of Cage Wheel with Opposing Circumferential Lugs amd Normal Cage Wheel in Wet Clay Soil (S. Soekarno, V.	

M. Salokhe).....	55
Fabrication and Testing of Tomato Seed Extractor (R. Kailappan, Parveen Kasur Baig, N. Varadharaju, K. Appavu, V. Krishnasamy)	62
Computer-Aided Analysis of Forces Acting on a Trailled Plough (Ying Yibin, Zhao Yun, Jin Juanqin).....	67
The Effects of Some Operational Parameters on Potato Planter's Performance (Ebubekir Altuntas)	71
The Use of Hot Air from Room Type Coolers for Drying Agricultural Products (Turhan Koyuncu, Yunas Pinar).....	75
Effect of Mechanization level and Crop Rotation on Yield Energy Requirements (S.K. Dash, D.K. Das).....	80
Simple Quality Evaluation of Chili Pepper Based on Continuous Weight Measurement During Dehydration Process (T.W. Widodo, H. Ishida, J. Tatsuno, K. Tajima, E. Sakaguchi, K. Tamaki).....	84



AGRICULTURAL MECHANIZATION IN ASIA, AFRICA AND LATIN AMERICA (Vol.37, No.1, Winter, 2006)

Evaluation of Solar Drying for Post Harvest Curing of Turmeric: <i>Curcuma longa</i> L. (J. John Gunasekar, S. Kaleemullah, P. Doraisamy, S. Kamaraj).....	9
Front Wheel Drive Effect on the Performance of the Agricultural Tractor (H. Ortiz-Laurel, D. Rössel, J.G. Hermosilo-Nieto) ...	14
Development and Performance Evaluation of a Test Rig for Mechanical Metering of Sunflower Seeds (Sukhbir Singh, D. N. Sharama, Jagvir Dixit, Dinesh Kumar Vasta)	18
Design Development and Performance Evaluation of a Saw Cylinder Cleaner for Mechanically Picked Cotton (S. K. Shukla, P. G. Patil, V. G. Arude).....	25
Design Development and Performance Evaluation of Portable Cotton Ginning Machines (P. G. Patil, V. G. Arude, S. K. Shukla).....	30
Design and Development of Power Operated Roller Type Lac Scraper (Niranjan Prased, K. K. Kumar, S. K. Panday, M. L. Bhagat)....	35
The Impact of Power Tillers on Small Farm Productivity and Employment in Bangladesh (R. I. Sarker, D. Barton)	38
Field Performance Evaluation od Power Tiller Operated Air Assisted Spraying System (A. G. Powar, V. V. Aware, S. K. Jain, A. P. Jaiswal)	46
Effect of Cone Angle on Droplet Spectrum of Hollow Cone Hydraulic Nozzles (S. K. Jain, K. G. Dhande, V. V. Aware, A. P. Jaiswal)	51
Feasibility of Using Yield Monitors for the Development of Soil Management Maps (Jay Radhakrishnan, V. Anbumozhi, Robert H. Hill, Raymond J. Miller)	54
Improving Whole Kernel Recovery in Ca-	

shew Nut Processing Specific to Nigeria Nuts (D. Balasubramanian)	58
Processing Factor Affecting the Yield and Physicochemical Properties of Starches from Cassava Chips and Flour (O. V. Olo-mo, O. O. Ajibola).....	65
Influence of Seeding Depth and Compaction on Germination (P. R. Jayan, V. J. F. Kumar, C. Divaker Durairaj).....	70
Testing, Evaluation and Modification of Manual Coiler for Drip Lateral (S. S. Taley, S. M. Bhende, V. P. Tale).....	75
Single Hydrocyclone for Cassava Starch Milk (A. Manickavasagan, K. Thangavel).....	80
Utilization Pattern of Power Tillers in Tamil Nadu (B. Shridar, P. K. Padmanathan, R. Manian).....	85



AGRICULTURAL MECHANIZATION IN ASIA, AFRICA AND LATIN AMERICA
(Vol.37, No.2, Spring, 2006)

Performance Evaluation of Bullock Drawn Puddlers (S. K. Dash, D. K. Das).....	9
Design of a Knapsack Sprayer for Local Fabrication (R. F. Orge, R. B. Benito).....	12
Current and Future Trends and Constraints in Iranian Agricultural Mechanization (Ahmad Tabatabaefar, Ali Hajeiahmad)	17
Comparative Evaluation of the Performance of Intermediate Agricultural Processing Technologies with Traditional Processing Techniques for Cereal Crops in South Africa (V. I. O. Ndirika, A. J. Buys)	24
Computer-Aided Design of Extended Octagonal Ring Transducer for Agricultural Implements (H. Raheman, R. K. Sahu).....	29
Optimization of Seed Rate of Direct Rice Seeder as Influenced by Machine and Operational Parameters (S. S. Sivakumar, R. Manian, K. Kathirvel).....	34
Reliability Analysis of Different Makes of Power Tillers (B. Shridar, P. K. Padmanathan, R. Manian).....	42
Design and Development of a Two-Row Saffron Bulb Planter (Mohammad-H. Saiedi Rad)	48
Determination of the Optimum Moisture Contents for Shelling Maize Using Local Shellers (I. K. Tastra, Erlina Ginting, Richard Merx)	51
The Influence of Various Factors on Tractor Selection (Ali Aybek, Ismet Boz).....	58
Effect of Impeller Materials on Centrifugal Pump Characteristics (Bahattin Akdemir, Birol kayisoglu, Senel Kocoglu).....	62
Performance Evaluation of a Safflower Harvester (Devanand Maski, T. Guruswamy) ..	68
Semi-Automatic VRT-Based Fertilization System Utilizing GPS (Moustafa A. Fadel, Ahmad El-Mowafy, Abdul Elghaffar Jomaa)	72
The Effect of Dilution Volume, Water Temperature and Pressing Time on Oil Yield from Thevetia Kernel during Extraction (A. F. Alonge, A. M. Olaniyan)	79
Postharvest Losses of Tomatoes in Transit (R. J. Bani, M. N. Josiah, E. Y. Kra).....	84
The Present State of Farm Machinery Industry (Shin-Norinsha Co., Ltd).....	87



AGRICULTURAL MECHANIZATION IN ASIA, AFRICA AND LATIN AMERICA
(Vol.37, No.3, Summer, 2006)

Optimisation of Machine Parameters of Pneumatic Knapsack Cotton Picker (K. Rangasamy, M. Muthamilselvan, C. Divaker Durairaj)	9
Tractor and Implement Ownership and Utilization of Haryana (Sandeep Yadav, S. Kumar Lohan)	15
Study on Different Tillage Treatments for Rice-Residue Incorporation and its Effect on Wheat Yield in Tarai Region of Uttaranchal (T. P. Singh, Jayant Singh, Raj Kumar)	18
A Comparative Study on the Crop Establishment Technologies for Lowland Rice (T. Pandiarajan, U. Solaippan, K. Rubapathi) ..	25
Design of Tractor Operated Rotary Cultivator - a Computer Simulation (H. Raheman, R. K. Sahu)	27
Machine-Crop Parameters Affecting Performance of an Axial-Flow Soya Bean Thresher (Anusorn Vejasit, Vilas M. Salokhe)	32
Prospects and Problems of Power Tillers in Selected Districts of North Eastern Hilly Region in India - a Case Study (E. V. Thomas, C. S. Sahay, K. K. Satapathy).....	39
Design and Development of Cylinder Type Cotton Pre-Cleaner (P. G. Patil, V. G. Arude, G. R. Anap)	46
The Effect of a Fogging System on Sensible and Latent Heat Transfer in a Rose Greenhouse (H. H. Öztürk).....	52
Evaluation of Wheat Bed Planting System in Irrigated Vertisols of Sudan (A. W. Adbelhadi, S. E. A. El Awad, M. A. Bashir, Takeshi Hata)	62
Subsoiling - a Strategy to Combat Water Scarcity and Enhanced Productivity of Groundnut Crop (K. K. Jain, V. R. Vagadia, L. P. Singh, A. H. Memon)	68
Evaluation of Practical Training in Uganda's Agricultural Engineering Curriculum (W. S. Kisaalita, J. B. Kawongolo, J. S. Kibalama)	71
Performance Evaluation of a Tractor-Operated Sugarcane Harvester (H. M. Al Sharief, M. A. Haque, N. A. Aviara).....	79
Role of Computers in Eco-Friendly and Sustainable Agriculture of the 21st Century (Madan K. Jha, V. M. Salokhe, Satish K. Jain)	85



AGRICULTURAL MECHANIZATION IN ASIA, AFRICA AND LATIN AMERICA
(Vol.37, No.4, Autumn, 2006)

Potential of Farm Mechanization in Jammu and Kashmir State of India- a Review (Jagvir Dixit, A. S. Jeena, N. C. Shahi, Tahir Wahid)	9
Case Study in the Conversion of Fired-Wood Fuel to other Suitable ones in the Rural Areas of Vietnam (Nguyen Hay, Le Quang Giang)	15
Establishment and Performance of an Indigenous Small Scale Rice Processing Plant in	

Nigeria (Gbabo Agidi).....	21
Evaluation of Soil-Water Conservation Tillage Systems for Communal Farmers in the Eastern Cape, South Africa (O. T. Mandir-ingana, M. Mabi, T. E. Simalenga).....	27
Recent Developments in Sugarcane Mechanisation in India (M. P. Sharma, S. R. Misra, Ashutosh Mishra).....	33
Performance Efficiency of an Active Evaporative Cooling System for the Storage of Fruits and Vegetables in a Semi Arid Environment (Adam U. Dzivama, J. C. Igbeka, I. Audu)	36
Inspection of Watermelon Maturity by Testing Transmitting Velocity of Acoustic Wave (Rao Xiuqin, Ying Yibin).....	42
Development and Testing of a Chillli Seed Extractor (M. Balakrishnan, V. Thirupathi, V. V. Sree Narayanan).....	46
Design and Fabrication of a Small-Scale Fruit Picker of Adjustable Height (Mohamad I. Al-Widyan, Hind M. Al-Qtob, Ahmad H. Hajeer)	49
Non Polluting Pesticide Application Window for Fruit Orchards in South Central Chile (Edmundo J. Hetz, Fernando A. Venegas, Marco A. Lopez).....	52
Performance Evaluation of an Evaporative Cooling System for Fruits and Vegetable Storage in the Tropics (F. A. Babarinsa).....	60
Development and Testing of a Tomato Pulper Cum Straner (V. Thirupathi, R. Viswanathan, K. Thangavel).....	66
Comparative Feasibility Analysis of Alternative Renewable Energy Sources for Small Milk Cooling Plants of Southwestern Uganda)	69
Development of Simple Pulper for Leaves of Green Plant (Julius K. Tangka).....	76
Constraints and Prospects of Agricultural Mechanisation in Samoa (Md. Wali Ullah)	81
Design and Development of an Off-Set Rotary Cultivator for Use with a Two-Wheel Tractor for Fruit Tree Cultivation (A. Senanarong, K. Wannaronk).....	87



INSTRUCTIONS TO AMA CONTRIBUTORS

The Editorial Staff of the AMA requests of articles for publication to observe the following editorial policy and guidelines in order to improve communication and to facilitate the editorial process:

Criteria for Article Selection

Priority in the selection of article for publication is given to those that –

- a. are written in the English language;
- b. are relevant: to the promotion of agricultural mechanization, particularly for the developing countries;
- c. have not been previously published elsewhere, or, if previously published are supported by a copyright permission;
- d. deal with practical and adoptable innovations by, small farmers with a minimum of complicated formulas, theories and schematic diagrams;
- e. have a 50 to 100-word abstract, preferably preceding the main body of the article;
- f. are printed, double-spaced, under 3,000 words (approximately equivalent to 6 pages of AMA-size paper) ; and those that
- g. art: supported by authentic sources, reference or bibliography.
- h. written on floppy disc or CD-R

Rejected/Accepted Articles

- a. As a rule, articles that are not chosen for AMA publication are not returned unless the writer(s) asks for their return and are covered with adequate postage stamps. At the earliest time possible, the writer(s) is advised whether the article is rejected or accepted.
- b. When an article is accepted but requires revision/modification, the details will be indicated in the return reply from the AMA Chief Editor in which case such revision/modification must be completed and returned to AMA within three months from the date of receipt from the Editorial Staff.
- c. "The AMA does not pay for articles published. However, the writers are given collectively 5 free copies (one copy air-mailed and 4 copies sent by surface/sea mail) of the AMA issue wherein their articles are published. In addition, a single writer is given 25 off-prints of the article and plural writers are given 35 off-prints (also sent by surface/sea mail)"
- d. Complimentary copies: Following the publishing, three successive issue are sent to the author(s).

Procedure

- a. Articles for publication (original and one-copy) must be sent to AMA through the Co-operating Editor in the country where the article originates. (Please refer to the names and addresses of Co-operating Editors in any issue of the AMA). However, in the absence of any Co-operating Editor, the article may be sent directly to the AMA Chief Editor in Tokyo.
- b. Contributors of articles for the AMA for the first time are required to attach a passport size ID photograph (black and white print preferred) to the article. The same applies to those who have contributed articles three years earlier. In either case, ID photographs

taken within the last 6 months are preferred.

- c. The article must bear the writer(s) name, title/designation, office/organization, nationality and complete mailing address.

Format/Style Guidance

- a. Article must be sent on 3.5 inch floppy disk or CD-R with MS DOS format (e.g. Word Perfect, Word for DOS, Word for Windows... **Absolutely necessary TEXT FORMAT**) along with two printed copy (A4).
- b. The data for graphs and the black & white photographs must be enclosed with the article.
- c. Whether the article is a technical or popular contribution, lecture, research result, thesis or special report, the format must contain the following features:
 - (i) brief and appropriate title;
 - (ii) the writer(s) name, designation/title, office/organization; and mailing address;
 - (iii) an abstract following ii) above;
 - (iv) body proper (text/discussion);
 - (v) conclusion/recommendation; and a
 - (vi) bibliography
- d. The printed copy must be numbered (Arabic numeral) successively at the top center whereas the disc copy pages should not be number. Tables, graphs and diagrams must likewise be numbered. Table numbers must precede table titles, e.g., "Table 1. Rate of Seeding per Hectare". Such table number and title must be typed at the top center of the table. On the other hand, graphs, diagrams, maps and photographs are considered figures in which case the captions must be indicated below the figure and preceded by number, e.g., "Figure 1. View of the Farm Buildings".
- e. **The data for the graph must also be included. (e.g. EXCEL for Windows)**
- f. Tables and figures must be preceded by texts or discussions. Inclusion of such tables and figures not otherwise referred to in the text/discussion must be avoided.
- g. Tables must be typed clearly without vertical lines or partitions. Horizontal lines must be drawn only to contain the sub-title heads of columns and at the bottom of the table.
- h. Express measurements in the metric system and crop yields in metric tons per hectare (t/ha) and smaller units in kilogram or gram (kg/plot or g/row).
- i. Indicate by footnotes or legends any abbreviations or symbols used in tables or figures.
- j. Convert national currencies in US dollars and use the later consistently.
- k. Round off numbers, if possible, to one or two decimal units, e.g., 45.5 kg/ha instead of 45.4762 kg/ha.
- l. When numbers must start a sentence, such numbers must be written in words, e.g., Forty-five workers..., or Five tractors..."instead of 45 workers..., or, 5 tractors.